

# Mini-3 IC 5.0

Indexable Threading Inserts for Small Bores



METRIC

## Mini-3 IC 5.0

### INSERTS

■ Partial Profile 60° .....	Page 3
■ Partial Profile 55° .....	Page 3
■ ISO Metric .....	Page 4
■ American UN .....	Page 5
■ Whitworth .....	Page 6
■ BSPT .....	Page 6
■ NPT .....	Page 7
■ NPTF .....	Page 7
■ Trapez .....	Page 8
■ American ACME .....	Page 8
■ Stub ACME .....	Page 9
■ PG .....	Page 9

### TOOLHOLDERS

■ Internal Toolholders - Standard .....	Page 10
■ Internal Toolholders - U Style .....	Page 10

### TECHNICAL DATA

■ Recommended Grades and Cutting Speeds .....	Page 11
---	---------

**VARGUS**  
**GEN**

Tool Selection and  
CNC Program Generator



The most popular and advanced thread turning and thread milling software on the market today.

Now available in 2 Versions at [www.vargus.com](http://www.vargus.com):

- Online Version
  - Online interactive software
  - For all web browsing environments
  - Most updated version always online
- Downloadable Version
  - Standalone software application
  - MS Windows OS-based program
  - Automatic updates

## Partial Profile 60°

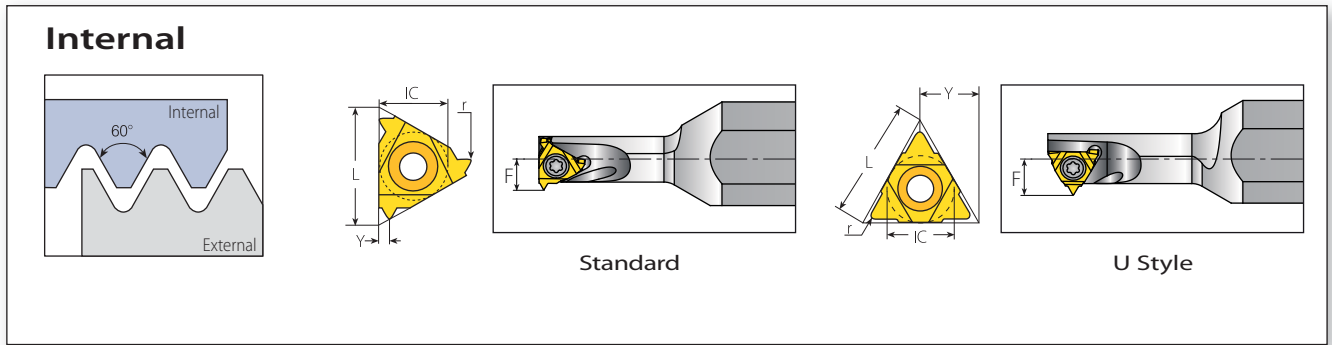

### Mini-3 Standard



Insert Size		Pitch		Ordering Code		Dimensions mm			Min. Bore dia.	
IC mm	L mm	mm	tpi	RH	LH	r	Y	F	mm	Toolholder
5.0	8	0.5-1.5	48-16	5.0KIRA60...	5.0KILA60...	0.05	0.7	4.7	7.8	(C)NVRC 7-5.0K

### Mini-3 U Style



Insert Size		Pitch		Ordering Code	Dimensions mm			Min. Bore dia.	
IC mm	L mm	mm	tpi	RH+LH	r	Y	F	mm	Toolholder
5.0U	8	1.75-2.0	14-11	5.0KUIB60...	0.16	4.0	5.8	9.0	(C)NVRC 8-5.0KU

## Partial Profile 55°

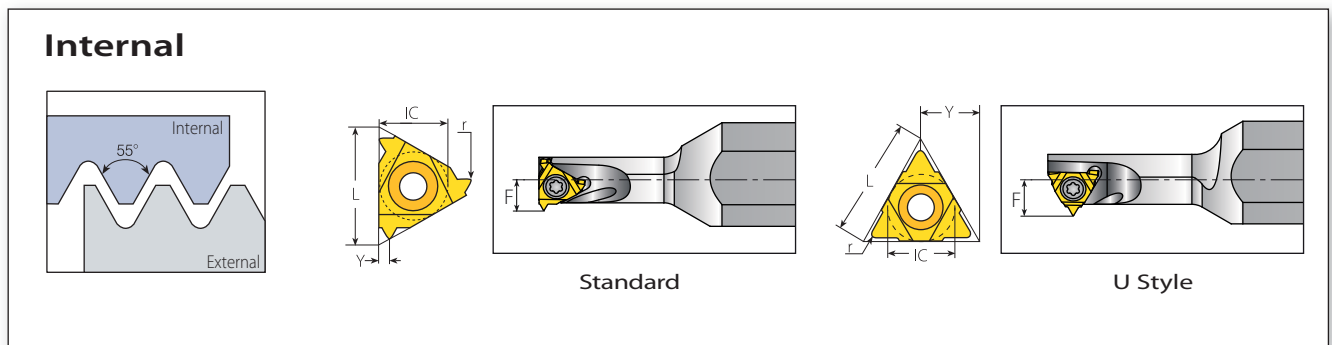

### Mini-3 Standard



Insert Size		Pitch		Ordering Code		Dimensions mm			Min. Bore dia.	
IC mm	L mm	mm	tpi	RH	LH	r	Y	F	mm	Toolholder
5.0	8	0.5-1.5	48-16	5.0KIRA55...	5.0KILA55...	0.05	0.7	4.7	7.8	(C)NVRC 7-5.0K

### Mini-3 U Style



Insert Size		Pitch		Ordering Code	Dimensions mm			Min. Bore dia.	
IC mm	L mm	mm	tpi	RH+LH	r	Y	F	mm	Toolholder
5.0U	8	1.75-2.0	14-11	5.0KUIB55...	0.21	4.0	5.7	9.0	(C)NVRC 8-5.0KU

## ISO Metric

### Internal

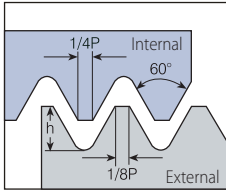

Defined by: R262 (DIN 13)  
Tolerance class: 6g/gH

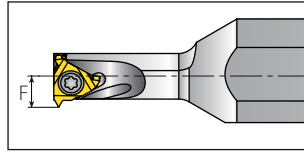
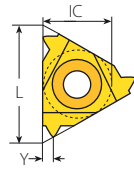

Standard

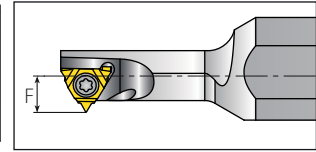
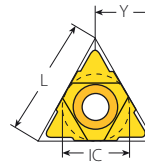

U Style

### Mini-3 Standard



Insert Size		Pitch	Ordering Code		Dimensions mm			Min. Bore dia.		Toolholder
IC mm	L mm	mm	RH	LH	h min	Y	F	mm		
5.0	8	0.5	5.0KIR0.5ISO...	5.0KIL0.5ISO...	0.29	0.5	4.7	7.8	(C)NVRC 7-5.0K	
		0.75	5.0KIR0.75ISO...	5.0KIL0.75ISO...	0.43	0.5				
		1.0	5.0KIR1.0ISO...	5.0KIL1.0ISO...	0.58	0.6				
		1.25	5.0KIR1.25ISO...	5.0KIL1.25ISO...	0.72	0.7				
		1.5	5.0KIR1.5ISO...	5.0KIL1.5ISO...	0.87	0.7				
		1.75	5.0KIR1.75ISO...	5.0KIL1.75ISO...	1.01	0.8				

### Mini-3 U Style



Insert Size		Pitch	Ordering Code		Dimensions mm			Min. Bore dia.		Toolholder
IC mm	L mm	mm	RH+LH	h min	Y	F	mm			
5.0U	8	2	5.0KUI2.0ISO...		1.23	4.0	5.7	9.0	(C)NVRC 8-5.0KU	

# American UN

**Internal**

Defined by: ANSI B1.1:74  
Tolerance class: 2A/2B

## Mini-3 Standard



Insert Size		Pitch	Ordering Code		Dimensions mm			Min. Bore dia.		Toolholder
IC mm	L mm	tpi	RH	LH	h min	Y	F	mm		
5.0	8	32	5.0KIR32UN...	5.0KIL32UN...	0.46	0.5	4.7	7.8	(C)NVRC 7-5.0K	
		28	5.0KIR28UN...	5.0KIL28UN...	0.52	0.6				
		24	5.0KIR24UN...	5.0KIL24UN...	0.61	0.6				
		20	5.0KIR20UN...	5.0KIL20UN...	0.73	0.7				
		18	5.0KIR18UN...	5.0KIL18UN...	0.81	0.7				
		16	5.0KIR16UN...	5.0KIL16UN...	0.92	0.7				
		14	5.0KIR14UN...	5.0KIL14UN...	1.05	0.8				

## Mini-3 U Style



Insert Size		Pitch	Ordering Code		Dimensions mm			Min. Bore dia.		Toolholder
IC mm	L mm	tpi	RH+LH	h min	Y	F	mm			
5.0U	8	13	5.0KUI13UN...	1.2	4.0	5.6	9.0	(C)NVRC 8-5.0KU		
		12	5.0KUI12UN...	1.3		5.7				
		11	5.0KUI11UN...	1.42		5.7				

## Whitworth - BSW, BSP (G), BSF, BSB

### Internal

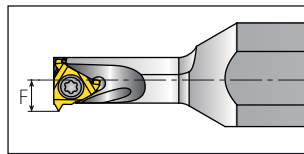
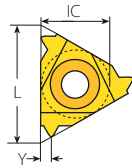
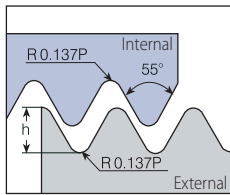

Standard

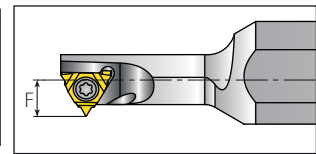
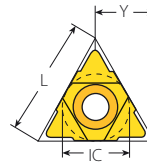

U Style

Defined by: B.S.84:1956, DIN 259, ISO228/1:1982  
Tolerance class: Medium class A

### Mini-3 Standard



Insert Size		Pitch	Ordering Code		Dimensions mm			Min. Bore dia.		Toolholder
IC mm	L mm	tpi	RH	LH	h min	Y	F	mm		
5.0	8	28	5.0KIR28W...	5.0KIL28W...	0.58	0.6	4.7	7.8	(C)NVRC 7-5.0K	
		24	5.0KIR24W...	5.0KIL24W...	0.68	0.6				
		20	5.0KIR20W...	5.0KIL20W...	0.81	0.7				
		19	5.0KIR19W...	5.0KIL19W...	0.86	0.7				
		18	5.0KIR18W...	5.0KIL18W...	0.90	0.7				
		16	5.0KIR16W...	5.0KIL16W...	1.02	0.7				

### Mini-3 U Style



Insert Size		Pitch	Ordering Code		Dimensions mm			Min. Bore dia.		Toolholder
IC mm	L mm	tpi	RH+LH	h min	Y	F	mm			
5.0U	8	14	5.0KUI14W...	1.16		5.6	9.0	(C)NVRC 8-5.0KU		
		12	5.0KUI12W...	1.36	4.0	5.7				
		11	5.0KUI11W...	1.48		5.7				

## BSPT

### Internal

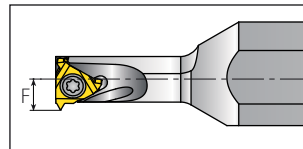
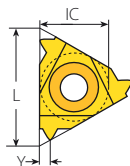
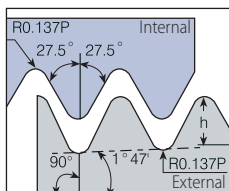

Standard

Defined by: B.S. 21:1985  
Tolerance class: Standard BSPT

### Mini-3 Standard



Insert Size		Pitch	Ordering Code		Dimensions mm			Min. Bore dia.		Toolholder
IC mm	L mm	tpi	RH	LH	h min	Y	F	mm		
5.0	8	28	5.0KIR28BSPT...	5.0KIL28BSPT...	0.58	0.6	4.7	7.8	(C)NVRC 7-5.0K	
		19	5.0KIR19BSPT...	5.0KIL19BSPT...	0.86	0.7				

# NPT

## Internal

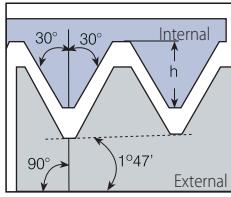

Defined by: USAS B2.1:1968  
Tolerance class: Standard NPT

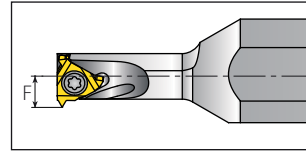
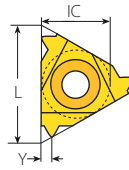

Standard

## Mini-3 Standard



Insert Size		Pitch	Ordering Code		Dimensions mm		Min. Bore dia.		
IC mm	L mm	tpi	RH	LH	h min	Y	F	mm	Toolholder
5.0	8	27	5.0KIR27NPT...	5.0KIL27NPT...	0.66	0.6	4.7	7.8	(C)NVRC 7-5.0K
		18	5.0KIR18NPT...	5.0KIL18NPT...	1.01	0.8			

# NPTF

## Internal

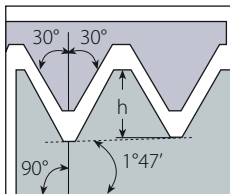

Defined by: ANSI B1.20.3-1976  
Tolerance class: Class 2

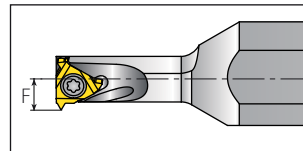
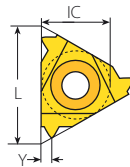

Standard

## Mini-3 Standard



Insert Size		Pitch	Ordering Code		Dimensions mm		Min. Bore dia.		
IC mm	L mm	tpi	RH	LH	h min	Y	F	mm	Toolholder
5.0	8	27	5.0KIR27NPTF...	5.0KIL27NPTF...	0.64	0.6	4.7	7.8	(C)NVRC 7-5.0K
		18	5.0KIR18NPTF...	5.0KIL18NPTF...	1.00	0.8			

# Trapez

## Internal

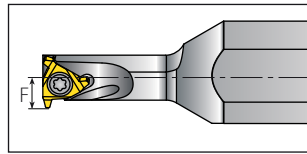
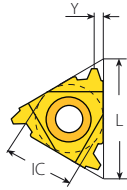
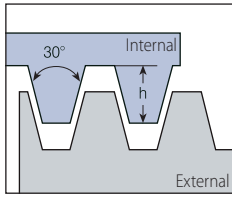

Standard

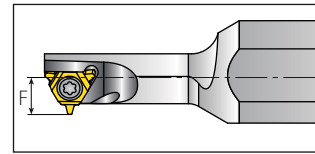
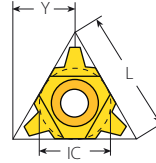

U Style

Defined by: B.S.84:1956, DIN 103  
Tolerance class: 7e/7H

## Mini-3 Standard



Insert Size		Pitch	Ordering Code		Dimensions mm			Min. Bore dia.	
IC mm	L mm	mm	RH	LH	h min	Y	F	mm	Toolholder
5.0	8	1.5	5.0KIR1.5TR...	5.0KIL1.5TR...	0.85	0.7	4.7	7.8	(C)NVRC 7-5.0K

## Mini-3 U Style



Insert Size		Pitch	Ordering Code		Dimensions mm			Min. Bore dia.	
IC mm	L mm	mm	RH+LH	h min	Y	F	mm	Toolholder	
5.0U	8	2.0	5.0KUI2TR...	1.25	4.0	5.7	9.0	(C)NVRC 8-5.0KU	

## American ACME

### Internal

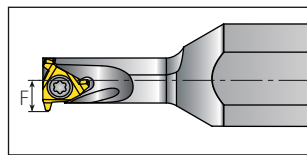
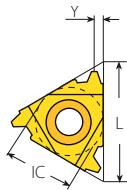
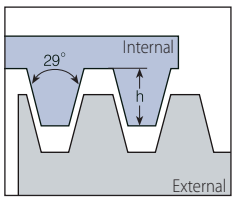

Standard

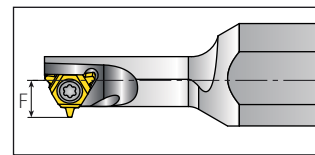
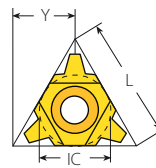

U Style

Defined by: ANSI B1.5:1988  
Tolerance class: 3G

## Mini-3 Standard



Insert Size		Pitch	Ordering Code		Dimensions mm			Min. Bore dia.	
IC mm	L mm	tpi	RH	LH	h min	Y	F	mm	Toolholder
5.0	8	16	5.0KIR16ACME...	5.0KIL16ACME...	0.92	0.7	4.7	7.8	(C)NVRC 7-5.0K

## Mini-3 U Style



Insert Size		Pitch	Ordering Code		Dimensions mm			Min. Bore dia.	
IC mm	L mm	tpi	RH+LH	h min	Y	F	mm	Toolholder	
5.0U	8	14	5.0KUI14ACME...	1.03	4.0	5.8	9.0	(C)NVRC 8-5.0KU	
		12	5.0KUI12ACME...	1.19					
		10	5.0KUI10ACME...	1.52					



## Stub ACME

### Internal

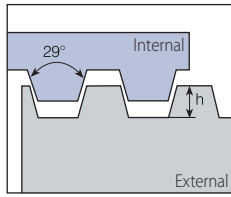

Defined by: ANSI B1.8:1988  
Tolerance class: 2G

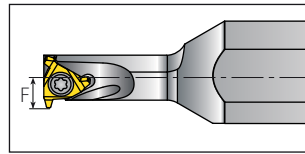
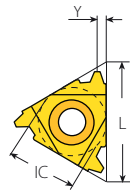

Standard

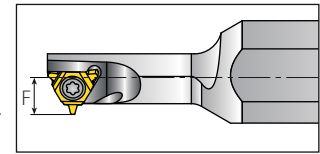
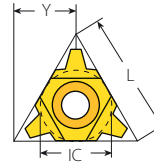

U Style

## Mini-3 Standard



Insert Size		Pitch	Ordering Code		Dimensions mm			Min. Bore dia.	
IC mm	L mm	tpi	RH	LH	h min	Y	F	mm	Toolholder
5.0	8	16	5.0KIR16STACME...	5.0KIL16STACME...	0.6	0.7	4.7	7.8	(C)NVRC 7-5.0K

## Mini-3 U Style



Insert Size		Pitch	Ordering Code		Dimensions mm			Min. Bore dia.	
IC mm	L mm	tpi	RH+LH	h min	Y	F	mm	Toolholder	
5.0U	8	14	5.0KUI14STACME...	0.67	4.0	5.8	9.0	(C)NVRC 8-5.0KU	
		12	5.0KUI12STACME...	0.76		5.7			
		10	5.0KUI10STACME...	1.02		5.6			

## PG

### Internal

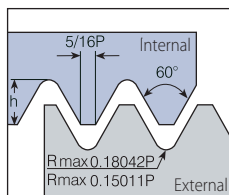

Defined by: MIL-S-8879C  
Tolerance class: 3A/3B

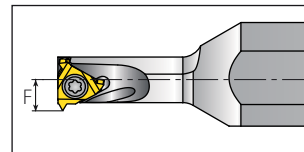
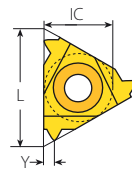

Standard

## Mini-3 Standard



Insert Size		Pitch	Ordering Code		Dimensions mm			Min. Bore dia.	
IC mm	L mm	tpi	RH	LH	h min	Y	F	mm	Toolholder
5.0	8	20	5.0KIR20PG...	5.0KIL20PG...	0.61	0.7	4.7	7.8	(C)NVRC 7-5.0K

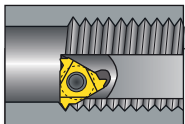

## Internal Toolholders Standard

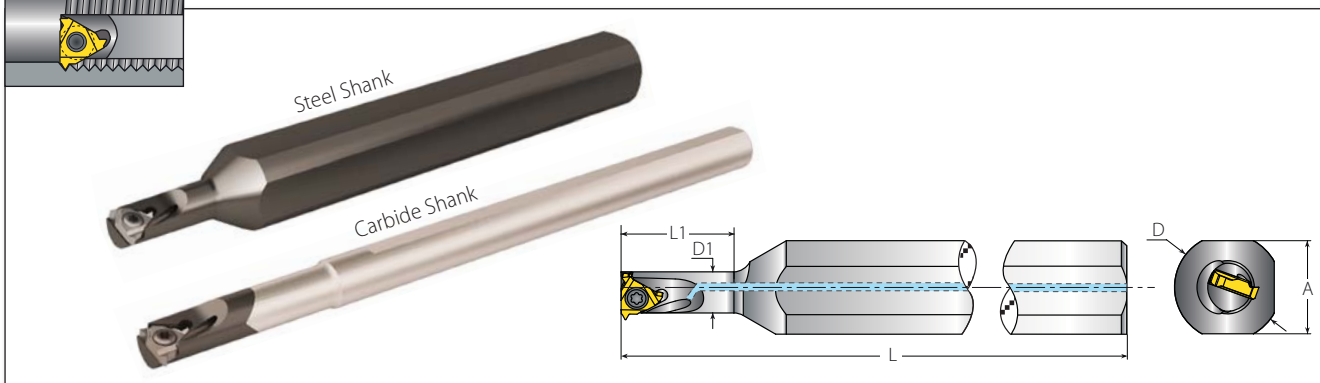

### Mini-3 Standard

Insert Size		Ordering Code	Dimensions mm				Anti-Vibration System	Spare Parts	
IC mm	RH/LH	A	L	L1	D	D1		Insert Screw	Torx Key
5.0	NVRC 7-5.0K	15	125	18	16	6.6	No	SN5MT	KIP6
	CNVRC 7-5.0K	7	125	31	8	6.6	Carbide Shank		

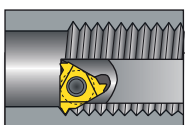

## Internal Toolholders U Style

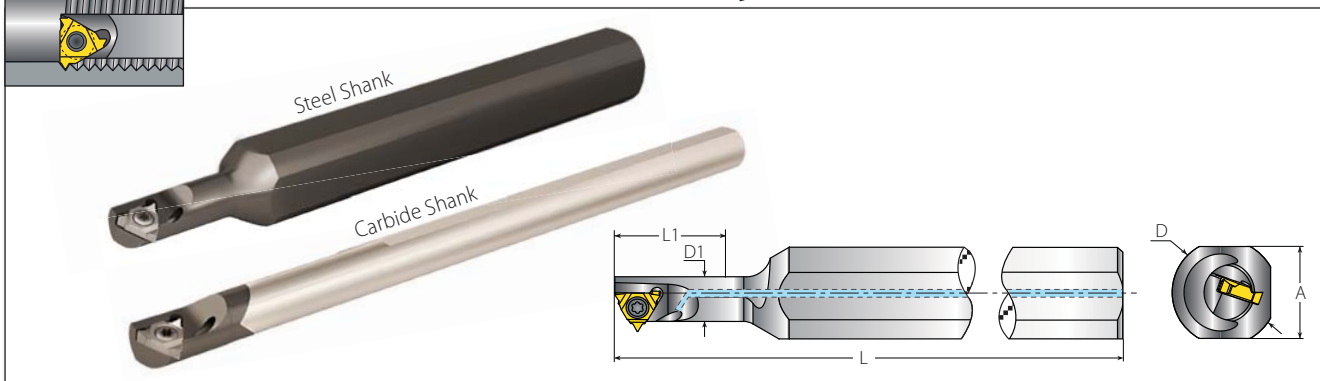

### Mini-3 U Style

Insert Size		Ordering Code	Dimensions mm				Anti-Vibration System	Spare Parts	
IC mm	RH/LH	A	L	L1	D	D1		Insert Screw	Torx Key
5.0U	NVRC 8-5.0KU	15	125	21	16	7.3	No	SN5MT	KIP6
	CNVRC 8-5.0KU	7	125	35	8	7.3	Carbide Shank		

# Recommended Grades and Cutting Speeds Vc [m/min] Mini-3 IC 5.0

Material Group	Vardex No.	Material	Hardness Brinell HB	Vc [m/min]	
				Coated	VBX / VTX
<b>P</b> Steel	1	Unalloyed steel	Low carbon (C=0.1-0.25%)	125	40-80
	2		Medium carbon (C=0.25-0.55%)	150	40-80
	3		High Carbon (C=0.55-0.85%)	170	40-80
	4	Low alloy steel (alloying elements ≤5%)	Non hardened	180	40-80
	5		Hardened	275	40-80
	6		Hardened	350	40-80
	7	High alloy steel (alloying elements >5%)	Annealed	200	40-60
	8		Hardened	325	40-60
	9	Cast steel	Low alloy (alloying elements <5%)	200	40-60
	10		High alloy (alloying elements >5%)	225	40-60
<b>M</b> Stainless Steel	11	Stainless steel Ferritic	Non hardened	200	40-60
	12		Hardened	330	40-60
	13	Stainless steel Austenitic	Austenitic	180	40-60
	14		Super Austenitic	200	40-60
	15	Stainless steel Cast Ferritic	Non hardened	200	40-60
	16		Hardened	330	40-60
	17	Stainless steel Cast austenitic	Austenitic	200	40-60
	18		Hardened	330	40-60
<b>K</b> Cast Iron	28	Malleable Cast iron	Ferritic (short chips)	130	40-80
	29		Pearlitic (long chips)	230	40-80
	30	Grey cast iron	Low tensile strength	180	40-80
	31		High tensile strength	260	40-80
	32	Nodular SG iron	Ferritic	160	40-80
	33		Pearlitic	260	40-80
<b>N(K)</b> Non-Ferrous Metals	34	Aluminium alloys Wrought	Non aging	60	40-120
	35		Aged	100	40-120
	36	Aluminium alloys	Cast	75	40-120
	37		Cast & aged	90	40-120
	38		Cast Si 13-22%	130	40-120
	39	Copper and copper alloys	Brass	90	40-120
	40		Bronze and non leaded copper	100	40-120
<b>S(M)</b> Heat Resistant Material	19	High temperature alloys	Annealed (Iron based )	200	
	20		Aged (Iron based)	280	
	21		Annealed (Nickel or Cobalt based)	250	
	22		Aged (Nickel or Cobalt based)	350	
	23	Titanium alloys	Pure 99.5 Ti	400Rm	
	24		α+β alloys	1050Rm	
<b>H(K)</b> Hardened Material	25	Extra hard steel	Hardened & tempered	45-50HRc	
	26			51-55HRc	

## Grades

Grade	Application
<b>VBX</b>	Carbide grade for Mini IC 5.0. For machining steel and general use. TiCN coated.
<b>VTX</b>	Carbide grade for Mini IC 5.0. For machining stainless steel and general use. TiAlN coated.

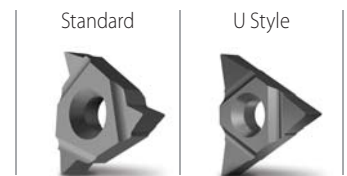

## Number of Passes

Pitch	mm	0.50	0.75	1.00	1.25	1.50	1.75	2.00
	tpi	48	32	24	20	16	14	12
No. of Passes		8-13	13-18	18-23	23-28	27-32	30-35	35-40



**VARDEX**  
Advanced Threading Solutions

**Mini-3 IC 5.0**  
Indexable Threading Inserts for Small Bores

