



VARDEX

Advanced Threading Solutions

MAIN CATALOG

Thread Turning

Thread Milling

METRIC

VARGUS is a world leading developer, manufacturer and supplier of high-quality, precision threading, grooving, turning and hand deburring tools.

Established in 1960, VARGUS is the cutting tools division of the NEUMO Ehrenberg Group, a multinational organization headquartered in Germany.

With 13 international subsidiaries, and a network of distributors, warehouses and certified ISO 9001 manufacturing facilities, VARGUS Ltd. serves customers in more than 100 countries around the globe. A customer-focused organization, VARGUS Ltd. is committed to providing products and solutions of the highest quality and excellent value, and is renowned for its technical expertise and uncompromising service.

COMPANY PRODUCTS:

VARDEX
Advanced Threading Solutions is the company's prominent product line for Thread Turning, Thread Milling, and Gear Milling Solutions.

Thread Turning: The VARDEX TT tools offer an extensive collection of pitches and standards in different grades, IC ranges and types of insert styles, as well as customized methods for the oil and gas industry.

Thread Milling: The VARDEX TM line provides a wide range of applications and solutions in multi-tooth, single-tooth for deep holes, and solid carbide tools.

Gear Milling: The VARDEX Gear Milling line is a revolutionary concept for gear, rack and spline applications, offered in indexable inserts and solid carbide tools.

VARGUS GENius™: VARGUS' industry-leading Thread Turning and Thread Milling solutions are seamlessly complimented by the VARGUS GENius™ software – The most powerful tool selector, cutting data and CNC program generating software.

GROOVEX
Innovative Grooving & Turning Solutions, the newest product line by VARGUS, provides innovative solutions for grooving, boring and turning, in a wide range of applications.

SHAVIV
Leading Deburring Solutions, manufactures world leading hand-deburring solutions for metals and plastics.





FLINE

Fixed Clamping System



VRX

Multipurpose Premium Grade



MEGALINE

For Extra Large Pitches



V-CAP Toolholders

Polygon Shaped Shanks



Oil&Gas

Professional Threading Solutions



Mini-3 IC 5.0

Tools for Small Applications



VG-Cut

Machining Between Shoulders



Mini-V

Miniature Vertical Tools



TMSD Vertical

Multi-Flute Vertical Tools



Contents

THREAD TURNING

Thread Turning System.....	12
----------------------------	----



Thread Turning Inserts 17

Vardex Ordering Code System.....	18
Partial Profile 60°	21
Partial Profile 55°	28
ISO Metric.....	34
American UN.....	49
Whitworth	63
BSPT	73
NPT.....	76
ANPT.....	82
NPTF	83
NPS.....	87
Round (DIN 405)	88
Round (DIN 20400).....	89
Trapez.....	93
American ACME.....	101
American ACME (2G)	108
Stub ACME	110
UNJ.....	115
MJ.....	120
American Buttress.....	122
British Buttress.....	126
Metric Buttress (Sägengewinde)	127
API.....	132
API Buttress Casing.....	134
API Round Casing & Tubing.....	138
VAM.....	144
New VAM.....	146
EL-Extreme Line.....	148
Hughes H-90.....	149
Pg.....	150



Thread Turning Toolholders 153

Vardex Ordering Code System.....	154
----------------------------------	-----

External Toolholders

Standard	156
Standard F-Line	157
V-CAP	157
Standard with Clamp.....	158
Oil & Gas.....	159
U Style	160
U Style with Clamp.....	160
Slim Throat.....	161
VG-Cut.....	162
V Style.....	163
Z+ Style	163
M+ Style.....	164
F-Line M+ Style.....	164
T+ Style.....	165
14D Standard.....	165
Off-Set Qualified (FQ).....	166
Drop Head-Qualified (CQ)	166
Miniature Square Shank.....	167
Miniature Round Shank.....	167

Internal Toolholders

Standard	168
Standard F-Line	169
V6 Style	169
V-CAP	170
Standard for Coarse Pitch.....	171
U Style for Coarse Pitch	171
Standard with Clamp.....	172
U Style	173
U style with Clamp.....	174
V Style.....	174

Z+ Style	175
M+ Style	175
F-Line M+ Style.....	176
T+ Style.....	176
14D Standard.....	177
14D Standard with Clamp.....	177
Oil & Gas.....	178
Standard with Carbide Shank.....	179
Mini-V	180
Mini-3 Standard.....	184
Mini-3 U Style	185
Mini-3 Adjustable.....	186
Mini-L.....	186
Mini-L Adjustable	187
Micro - Double Ended.....	187
Microscope - Single Ended.....	188
Thread Turning Kits.....	192



TT Technical Data 195

Thread Terminology	196
Machining a Multi-Start Thread.....	197
Insert Profile Styles	197
Thread Turning Methods for Symmetrical Inserts	198
Thread Infeed Methods.....	198
Thread Turning Methods for Asymmetrical Inserts	199
Calculating the Helix Angle	200
Anvils.....	201
Oil & Gas Anvils.....	202
Anvil Kits	202
Spare Parts.....	203
Grades and Their Applications.....	204
Recommended Grades and Cutting Speeds.....	206
Cutting Conditions Parameters.....	210
Number of Passes	211
Depths of Cut and Number of Passes for Mini-V	211
Number of Passes and Depth of Cut for Multi+	212
Step by Step Thread Turning.....	214
Material Comparison Table	218
Troubleshooting	222

THREAD MILLING

Thread Milling Systems	226
Thread Milling Methods.....	228
The Thread Milling Advantages	229



MiTM 231

Vardex Ordering Code System.....	232
----------------------------------	-----

MiTM Inserts

ISO Metric.....	234
American UN.....	235
Whitworth	237
NPT	238
NPTF	238
BSPT	239
Plug Insert.....	239

MiTM Toolholders

Standard Toolholders (MiTM 19).....	240
Conical Toolholders (MiTM 19)	241
Standard Toolholders (MiTM 24).....	242
Conical Toolholders (MiTM 24)	243
Standard Toolholders (MiTM 25).....	244
Conical Toolholders (MiTM 25)	245
Shell Mill (MiTM 25).....	246
Standard Toolholders (MiTM 40).....	247
Shell Mill (MiTM 40).....	248
Standard Toolholders (MiTM 41).....	249
Shell Mill (MiTM 41).....	250
Recommended Grades, Cutting Speeds and Feed	251



STANDARD Thread Milling..... 253

Vardex Ordering Code System.....	254
----------------------------------	-----

Standard Inserts

ISO Metric.....	256
American UN.....	261
UNJ.....	268
Whitworth	269

NPT.....	273
NPTF (Dry Seal).....	274
NPS.....	275
BSPT.....	276
Pg.....	277
ACME.....	278
Trapez.....	279

Standard Toolholders

TM Standard.....	280
TML Long Tools.....	282
124/... - For Coarse Pitch Threads.....	284
TMN - For Conical Threads.....	286
TM2 - Twin Flutes.....	288
TMO - Twin Flute Offset.....	289
TM Shell Mill.....	290
TMS - Single Point (Standard Inserts).....	292
TMV - Single Point (Vertical Insert).....	292
Recommended Grades, Cutting Speeds and Feed.....	293



TMSD..... 295

Vardex Ordering Code System.....	296
----------------------------------	-----

TMSD Vertical Inserts

Partial Profile 60°.....	298
Partial Profile 55°.....	299
Trapez.....	300
Stub ACME.....	300

TMSD Vertical Toolholders

Vertical Toolholders Weldon Shank.....	301
Vertical Toolholders Carbide Cylindrical Shank.....	302

TMSD Inserts

Partial Profile 60°.....	303
Partial Profile 55°.....	304
ISO Metric.....	305
American UN.....	306
NPT.....	307
Trapez.....	308
American ACME.....	309

Stub ACME.....	309
American Buttress.....	310
API Round Casing & Tubing.....	311

TMSD Toolholders

Standard Toolholders Weldon Shank (U Style).....	312
Standard Toolholders Carbide Cylindrical Shank (U Style).....	314
Standard Toolholders Steel Cylindrical Shank (U Style).....	316
Shell Mill (U Style).....	318
Standard Toolholders Weldon Shank (L Style - Mini L).....	320
Standard Toolholders Carbide Cylindrical Shank (L Style - Mini L).....	322
Standard Toolholders Weldon Shank (L Style - 3/8" L).....	324
Standard Toolholders Carbide Cylindrical Shank (L Style - 3/8" L).....	325
Shell Mill (L Style - 3/8" L).....	326
Shell Mill (5/8" V Style).....	327
Standard Toolholders Steel Cylindrical Shank (A Style).....	328
Recommended Grades, Cutting Speeds and Feed.....	329



TM Solid..... 331

Vardex Ordering Code System.....	332
Helicool.....	334
Helicool-R (HCR).....	343
Helicool-C (HCC).....	343
HTC (Thriller).....	344
Helical.....	345
Deep Threading.....	349
MilliPro.....	351
MilliPro Dental.....	354
MilliPro EL.....	355
MilliPro HD.....	356
Straight.....	358
Recommended Grades, Cutting Speeds and Feed.....	366



TM Technical Data..... 369

About Thread Milling.....	370
---------------------------	-----

Preparing for the Thread Milling Operation.....	372
List of "G" Codes (ISO) for CNC Program.....	373
Minimum Bore Diameters for TM Standard line	374
Spare Parts.....	376
Troubleshooting	378

MINI PRO



MiniPro Inserts 381

Vardex Ordering Code System.....	382
----------------------------------	-----

PowerBore Inserts

CD0W Inserts	383
TD0W Inserts.....	383
WC0W Inserts	384

Micro Boring Inserts

Micro Boring - Boring	385
Micro Boring - Copy.....	386
Micro Boring - Chamfer.....	386
Micro Boring - Long Nose.....	387
Micro Boring - Back Boring.....	388
Micro Boring - Boredrill.....	388

Micro Grooving Inserts

DIN 472 Retaining Ring Grooves for Bores	389
DIN 7993 Snap Ring Grooves.....	391
DIN 3770 - Grooves.....	392
DIN 471 DIN 472 - Face Grooving	393



MiniPro Toolholders..... 395

Vardex Ordering Code System.....	396
PowerBore Toolholders.....	397
Micro Toolholders	401



MiniPro Technical Data 403

Recommended Grades, Cutting Speeds and Feed	404
Spare Parts.....	405

VARGUS GENius™ – The most powerful tool selector, cutting data and CNC program generating software for the metal cutting tools industry.

Thread Turning:

The Vargus GENius™ guides the user to the right tool and the best cutting conditions for the application.

Thread Milling:

In a few simple steps, the Vargus GENius™ provides the user with the best tool and optimal machining data, as well as the G-Code for all popular CNC machines.

The VARGUS GENius™ is free and available in 16 languages in Online, Desktop, and .EXE versions.

VARGUS GENius™ | Tool Selector and CNC Program Generator

The most popular and advanced thread turning and thread milling software on the market today.



Now available in 3 versions at www.vargus.com

VARGUS
GENius™
ONLINE

- Online interactive software
- Always on, always updated!

VARGUS
GENius™
DESKTOP

- Stand-alone software application
- MS Windows OS-based program
- Automatic updates

VARGUS
GENius™
setup.exe

- USB memory devices
- MS Windows operating system-based program
- To install, open ZIP and click Setup.exe

Whether you require a non-standard size, a complex shape or a special design, the Vargus Custom Made Solutions team has the experience and know-how for essentially any tooling solution.

Working closely with the customer, VARGUS engineers provide the best solution for your operation, as well as guide and advise in the implementation of the customized machining process.

The Custom Made Solutions team has all of the know-how to design the right cutting tool, using the latest techniques and top-of-the-line technology.

Contact your VARGUS Sales Representative for more details.



Quality | Innovation | Service

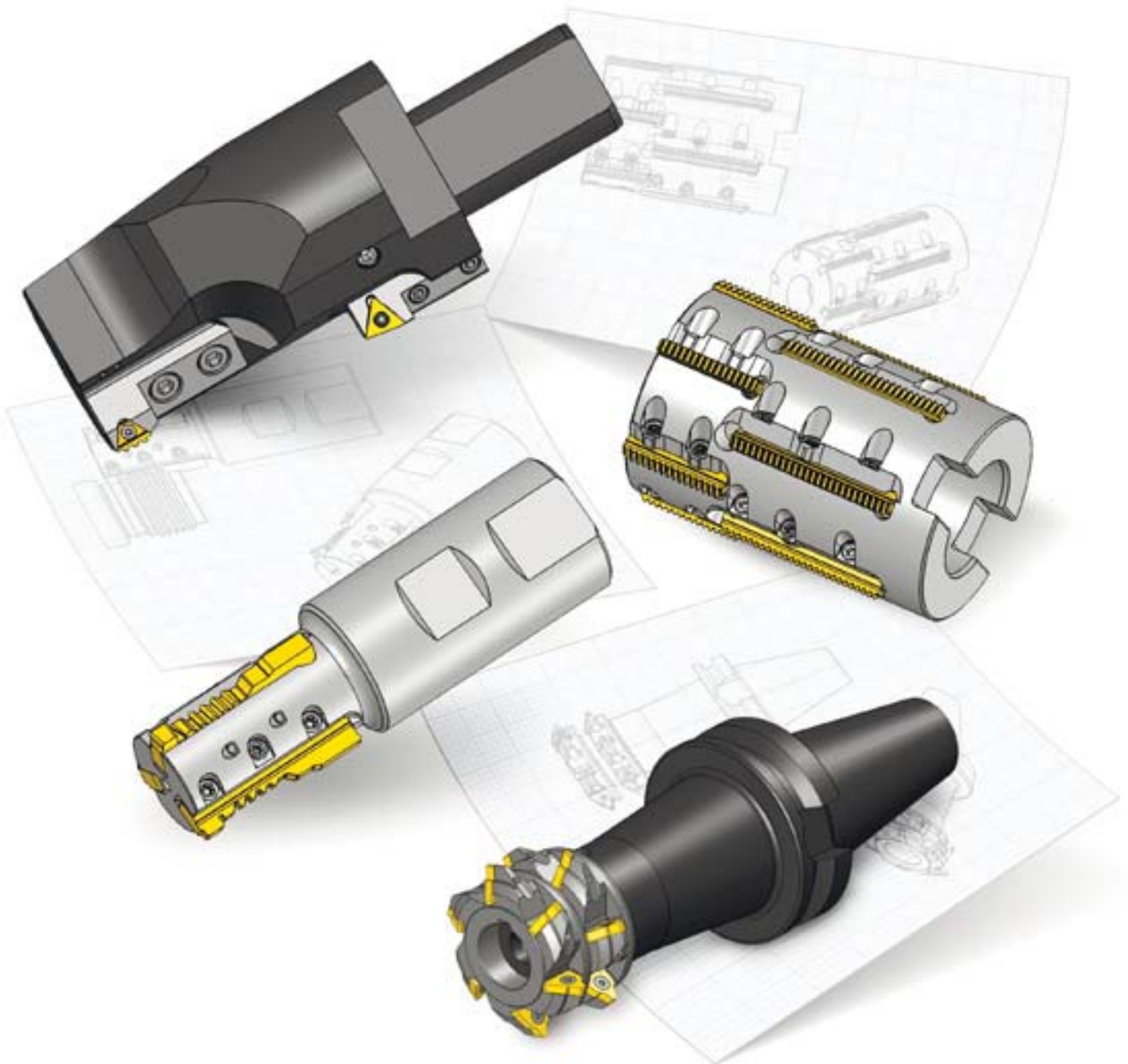

GEAR MILLING

Advanced Technologies for Gear, Spline and Rack Manufacturing



Revolutionary and cost-effective solutions for Gear, Spline & Rack applications, tailor-made to order or available as standard.

The complete Gear Milling Product Catalog is available at www.vargus.com



Gear Milling Tool Range



End Mill



Shell Mill



Disc Mill



Solid Carbide



THREAD TURNING

■ Inserts	17
■ Toolholders	153
■ Technical Data	195

Thread Turning System - EXTERNAL

Standard

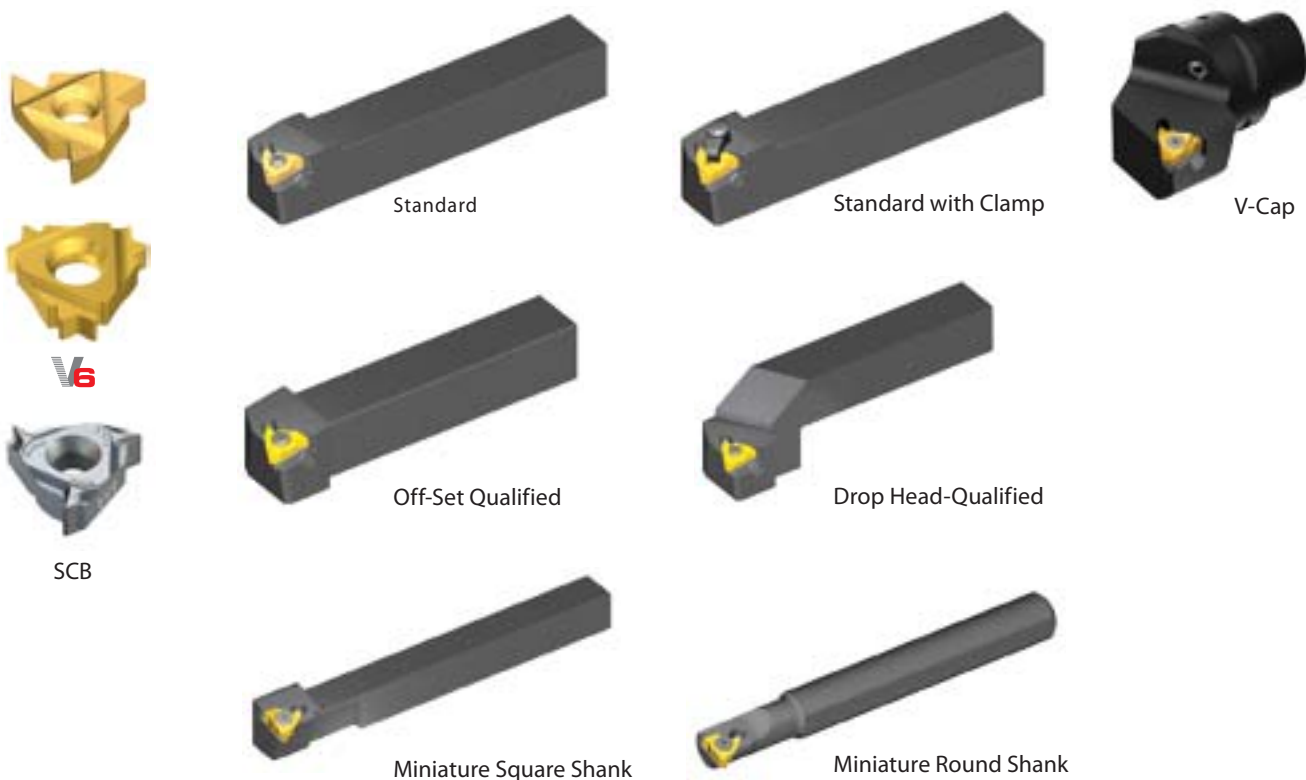

FLINE



U Style



V Style



VG-Cut



Thread Turning System - EXTERNAL

V Style



5/8"V



V Style

MEGALINE



5/8"MG



MG Style

Multiplus



M+ Style



FLINE



MF+ Style



Z+ Style



T+ Style

Oil&Gas



14D



14D Standard



CNGA



Chaser



T+ Style



On Edge

Thread Turning System - INTERNAL

Standard

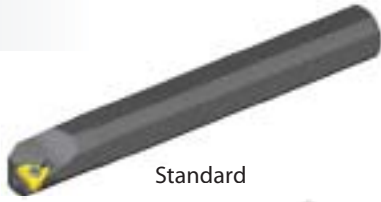

Standard



Standard with Clamp



V-Cap



Oil & Gas



Carbide Shank



SCB



Miniature Square Shank



Miniature Round Shank

FLINE



F Style

U Style



U Style



U Style with Clamp

V Style



5/8"V



V Style

MEGALINE



5/8"MG



MG Style

Multiplus



M+ Style



FLINE



MF+ Style



Z+ Style



T+ Style

Thread Turning System - INTERNAL

Mini-V



Steel Shank



Carbide Shank



Sleeve Clamping Shank

MINIPRO



Mini-3
 IC 4.0, IC 5.0, IC 6.0



Steel Shank /
 Carbide Implanted Shank



Mini-3 Adjustable



Carbide Shank



Mini-5L



Steel Shank /
 Carbide Implanted Shank



Mini-5L Adjustable

MINIPRO



Micro Double-Ended



Micro Sleeve

microscope



Micro Single-Ended



2 Flats Round Shank



4 Flats Round Shank



Square Shank



Drop Head

Oil&Gas



14D



14D



14D with Clamping



CNGA



Chaser



T+ Style



On Edge

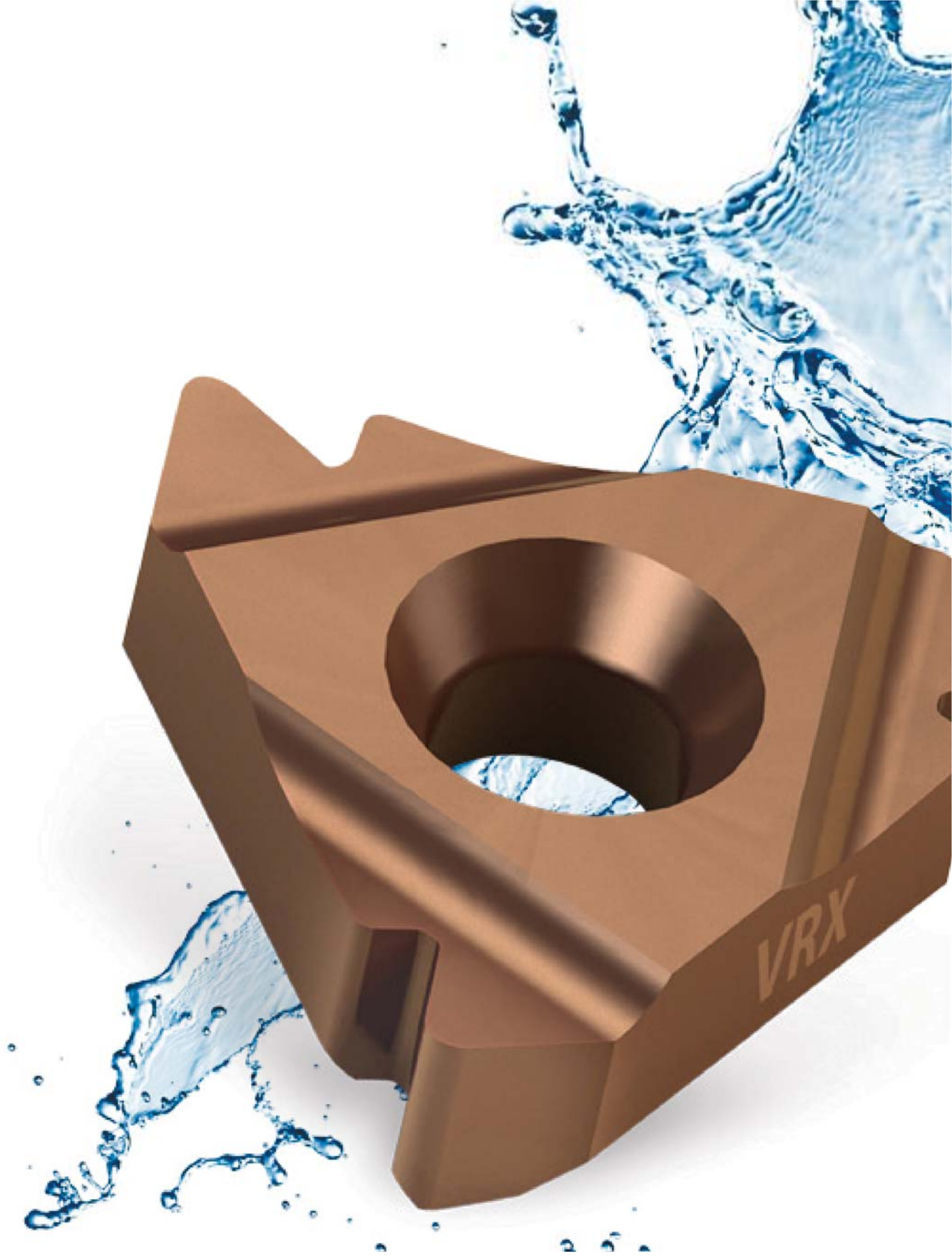

Thread Turning Inserts

Vardex Ordering Code System

■ Threading Inserts



3		E	R	1.5	ISO					VTX	
1	2	3	4	5	6	7	8	9	10	11	12

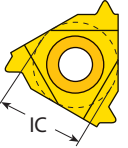

1 - Insert Size

5L - IC5.0L mm
 4.0K - IC4.0 mm
 5.0K - IC5.0 mm
 6.0 - IC6.0 mm
 2 - IC1/4"
 3 - IC 3/8"
 4 - IC 1/2"
 5 - IC5/8"
 14D - 14D
 1616 - Chaser size 16x16



2 - Insert Style

U  V  MG 
 U Style Vertical Mega Line

L  J  F 
 Mini-L SCB F-Line

3 - Type of Insert

E - External
 I - Internal
 EI - External + Internal

4 - RH/LH Insert

R - Right Hand Insert
 L - Left Hand Insert
 None - Right + Left Insert

5 - Pitch

Full Profile - Pitch Range		
mm	tpi	
0.35-25.0	72-1	
Partial Profile - Pitch Range		
mm	tpi	
A 0.5 - 1.5	48 - 16	
AG 0.5 - 3.0	48 - 8	
G 1.75 - 3.0	14 - 8	
N 3.5 - 5.0	7 - 5	
U 5.5 - 8.0	4.5 - 3.25	
Q 5.5 - 6.0	4.5 - 4	
U 6.5 - 9.0	4 - 2.75	
V 6.0 - 10.0	4 - 2.5	
S 0.5 - 2.0	48 - 13	

6 - Standard

60 - Partial Profile 60°	STACME - Stub ACME
55 - Partial Profile 55°	UNJ - UNJ
ISO - ISO Metric	MJ - ISO 5855
UN - American UN	ABUT - American Buttress
W - Whitworth for BSW, BSP	BBUT - British Buttress
BSPT - British Standard Pipe Thread	SAGE - Metric Buttress DIN 513
NPT - NPT	API - API
ANPT - ANPT	BUT - API Buttress Casing
NPTF - NPTF	APIRD - API Round Casing & Tubing
NPS - NPS	VAM - VAM
RD - Round DIN 405	NVAM - New Vam
RD20400 - Round DIN 20400	EL - Extreme Line Casing
TR - Trapez DIN 103	H90 - H90
ACME - ACME	PG - Pg DIN 40430

7 - No. of Cutting Corners

6C - V6 Cutting Corners



8 - API Form



382
383
403
502
503
652

9 - No. of Teeth

(for Multitooth Style)
 2, 3, 5, 6, 8

10 - Multitooth Style

M+  T+  **Multiplus**

Z+  S+ 

11 - Carbide Grade

VKX, VTX, VCB, VM7, VK2, VK2P,
 VHX, VBX, VRX, VTXP, VKXP, VRXP

12 - Coarse Pitch Inserts

158/...

Micro Threading Inserts - Double Ended

3	S	I	R	0.5	ISO	VMX												
1	2	3	4	5	6	7												
1 - Insert Dia.	2 - Insert Style		3 - Type of Insert		4 - RH/LH Insert		5 - Pitch											
3.0 - 3.0 mm 4.0 - 4.0 mm 6.0 - 6.0 mm 8.0 - 8.0 mm 10.0 - 10.0 mm	S - Micro Insert		I - Internal		R - Right Hand Insert L - Left Hand Insert		Full Profile - Pitch Range <table border="1"> <thead> <tr> <th>mm</th> <th>tpi</th> </tr> </thead> <tbody> <tr> <td>0.30-1.5</td> <td>40-16</td> </tr> </tbody> </table> Partial Profile - Pitch Range <table border="1"> <thead> <tr> <th>mm</th> <th>tpi</th> </tr> </thead> <tbody> <tr> <td>A 0.5 - 1.5</td> <td>A 48 - 16</td> </tr> <tr> <td>F 0.5 - 3.0</td> <td>F 48 - 24</td> </tr> </tbody> </table>		mm	tpi	0.30-1.5	40-16	mm	tpi	A 0.5 - 1.5	A 48 - 16	F 0.5 - 3.0	F 48 - 24
mm	tpi																	
0.30-1.5	40-16																	
mm	tpi																	
A 0.5 - 1.5	A 48 - 16																	
F 0.5 - 3.0	F 48 - 24																	
6 - Standard			7 - Carbide Grades															
60 - Partial Profile 60° 55 - Partial Profile 55° ISO - ISO Metric MJ - ISO 5855 NPT - NPT NPTF - NPTF UN - American UN W - Whitworth for BSW, BSP			VMX															

microscope

Micro Threading Inserts - Single Ended

M	5	42	TH	0.5	ISO	L16	R	VBX										
1	2	3	4	5	6	7	8	9										
1 - Product Line	2 - Insert Size		3 - Min. Bore Dia.															
M, MS - Microscope	4, 5, 6		3.2, 4.2,...															
4 - Type of Application			5 - Pitch (for Threading)			6 - Threading Standard												
TH - Threading			Full Profile - Pitch Range <table border="1"> <thead> <tr> <th>mm</th> <th>tpi</th> </tr> </thead> <tbody> <tr> <td>0.5-1.5</td> <td>32-16</td> </tr> </tbody> </table> Partial Profile - Pitch Range <table border="1"> <thead> <tr> <th>mm</th> <th>tpi</th> </tr> </thead> <tbody> <tr> <td>A 0.5 - 1.5</td> <td>A 48 - 16</td> </tr> <tr> <td>F 0.5 - 1.0</td> <td>F 48 - 24</td> </tr> </tbody> </table>			mm	tpi	0.5-1.5	32-16	mm	tpi	A 0.5 - 1.5	A 48 - 16	F 0.5 - 1.0	F 48 - 24	60 - Partial Profile 60° 55 - Partial Profile 55° ISO - ISO Metric UN - American UN W - Whitworth for BSW, BSP NPT - NPT		
mm	tpi																	
0.5-1.5	32-16																	
mm	tpi																	
A 0.5 - 1.5	A 48 - 16																	
F 0.5 - 1.0	F 48 - 24																	
7 - Overhang			8 - LH or RH			9 - Carbide Grades												
L16			R - RH Helix L - LH Helix			VBX												

■ CNGA and On Edge Inserts for Oil & Gas

C	N	G	A	6	4	I	R	5	BUT75	VKX
T	N	E	C	4	3	E	R	4	APIRD	VKX
1	2	3	4	5	6	7	8	9	10	11

1 - Insert Shape 	2 - Clearance Angle on Major Cutting Edge 	3 - Tolerances <table border="1"> <tr> <td>IC</td> <td>S</td> <td>m</td> </tr> <tr> <td>Theoretical diameter of inscribed circle</td> <td>Insert thickness</td> <td></td> </tr> <tr> <td>E</td> <td>±0,025</td> <td>±0,025</td> </tr> <tr> <td>G</td> <td>±0,025</td> <td>±0,13</td> </tr> </table>	IC	S	m	Theoretical diameter of inscribed circle	Insert thickness		E	±0,025	±0,025	G	±0,025	±0,13	4 - Clamp Type
IC	S	m													
Theoretical diameter of inscribed circle	Insert thickness														
E	±0,025	±0,025													
G	±0,025	±0,13													

5 - Theoretical diameter of inscribed circle 4 - 1/2" (12.7 mm) 5 - 5/8" (15.875 mm) 6 - 6/8" (19.05 mm)	6 - Thickness 3 - 3/16" (4.76 mm) 4 - 4/16" (6.35 mm) 5 - 5/16" (7.94 mm) 6 - 6/16" (9.525 mm)	7 - Type of Insert E - External I - Internal EI - External + Internal	8 - RH/LH Insert R - Right Hand Insert L - Left Hand Insert	9 - Pitch 10-5 tpi
--	---	---	--	------------------------------

10 - Standard ACME - ACME STACME - Stub ACME API - API BUT - API Buttress Casing APIRD - API Round Casing & Tubing	VAM - VAM NVAM - New VAM EL - Extreme Line Casing H90 - H90	11 - No. of Teeth (For Multitooth Style) T3-T5	12 - Carbide Grades VKX, VKXP, VTX, VTXP
--	--	---	--

■ VG-Cut Inserts

VG	D	3.0	ISO	1.50	RH	-	RS	VPG
1	2	3	4	5	6		7	8

1 - Line Name VG - Deep Grooving, Threading & Parting Off	2 - Number of Cutting Corners D - Double	3 - Inserts Width 3.0 mm	4 - Standard 60 - Partial Profile 60° 55 - Partial Profile 55° ISO - ISO Metric UN - American UN W - Whitworth for BSW, BSP NPT - NPT								
5 - Pitch Full Profile - Pitch Range <table border="1"> <tr> <td>mm</td><td>tpi</td> </tr> <tr> <td>0.5-2.0</td><td>32-11.5</td> </tr> </table> Partial Profile - Pitch Range <table border="1"> <tr> <td>mm</td><td>tpi</td> </tr> <tr> <td>A 0.5 - 1.5</td><td>48 - 16</td> </tr> </table>	mm	tpi	0.5-2.0	32-11.5	mm	tpi	A 0.5 - 1.5	48 - 16	6 - RH/LH Inserts RH Helix LH Helix	7 - Top Rake Geometry RS - Close to right shoulder LS - Close to left shoulder	8 - Carbide Grade VPG
mm	tpi										
0.5-2.0	32-11.5										
mm	tpi										
A 0.5 - 1.5	48 - 16										

■ Mini-V Inserts

V	08	TH	1.5	ISO	R	VBX
1	2	3	4	5	6	7

1 - Product Line V - Mini-V	2 - Insert Style 08, 11, 14, 16	3 - Type of Application TH - Threading	4 - Pitch (for Threading) Full Profile - Pitch Range <table border="1"> <tr> <td>mm</td><td>tpi</td> </tr> <tr> <td>0.5-2.0</td><td>32-12</td> </tr> </table> Partial Profile - Pitch Range <table border="1"> <tr> <td></td><td>mm</td><td></td><td>tpi</td> </tr> <tr> <td>H</td><td>0.5-.75</td><td>H</td><td>48-32</td> </tr> <tr> <td>I</td><td>1.0-1.25</td><td>I</td><td>24-20</td> </tr> <tr> <td>J</td><td>1.5-1.75</td><td>J</td><td>16-14</td> </tr> <tr> <td>G</td><td>1.75-3.0</td><td>G</td><td>14-8</td> </tr> <tr> <td>AG</td><td>0.5-3.0</td><td>AG</td><td>48-8</td> </tr> </table>	mm	tpi	0.5-2.0	32-12		mm		tpi	H	0.5-.75	H	48-32	I	1.0-1.25	I	24-20	J	1.5-1.75	J	16-14	G	1.75-3.0	G	14-8	AG	0.5-3.0	AG	48-8	5 - Threading Standard 60 - Partial Profile 60° 55 - Partial Profile 55° ISO - ISO Metric UN - American UN W - Whitworth for BSW, BSP BSPT - British Standard Pipe Thread NPT - NPT National Pipe Thread NPTF - NPTF National Seal Pipe Thread TR - Trapez Din 103
mm	tpi																															
0.5-2.0	32-12																															
	mm		tpi																													
H	0.5-.75	H	48-32																													
I	1.0-1.25	I	24-20																													
J	1.5-1.75	J	16-14																													
G	1.75-3.0	G	14-8																													
AG	0.5-3.0	AG	48-8																													
6 - RH R - RH Helix	7 - Carbide Grade VBX																															

Partial Profile 60°

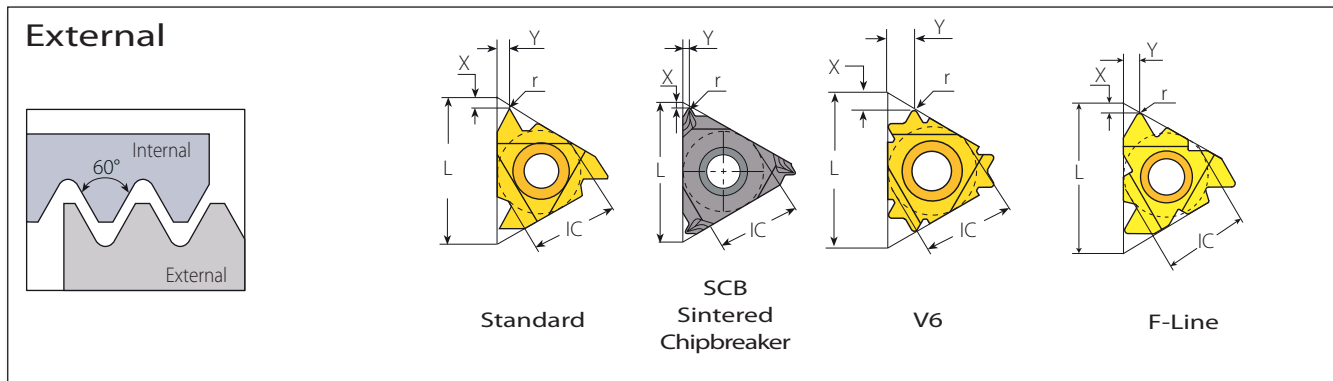

Standard



SCB



V6



F-Line

Insert Size		Pitch		Ordering Code		Dimensions mm			Anvil		Toolholder
IC	L mm	mm	tpi	RH	LH	r	X	Y	RH	LH	
1/4"	11	0.5-1.5	48-16	2ERA60...	2ELA60...	0.05	0.8	0.9	-	-	NL..-2 (LH)
		0.5-1.5	48-16	3ERA60...	3ELA60...	0.05	0.8	0.9	-	-	-
3/8"	16	1.75-3.0	14-8	3ERG60...	3ELG60...	0.27	1.2	1.7	YE3	YI3	AL..-3 (LH)
		0.5-3.0	48-8	3ERAG60...	3ELAG60...	0.08	1.2	1.7	-	-	-
3/8" SCB	16	0.5-1.5	48-16	3JERA60...	-	0.05	0.6	0.8	-	-	-
		1.75-3.0	14-8	3JERG60...	-	0.27	1.1	1.5	YE3	-	AL..-3
		0.5-3.0	48-8	3JERAG60...	-	0.08	0.9	1.5	-	-	-
3/8" V6	16	0.5-2.0	48-13	3ERS60-6C...	-	0.06	1.9	3.0	YE3-6C	-	AL..-3
1/2"	22	3.5-5.0	7-5	4ERN60...	4ELN60...	0.53	1.7	2.5	YE4	YI4	AL..-4 (LH)
1/2"F	23	3.5-5.0	7-5	4FERN60...	-	0.53	1.7	2.5	YE4F	-	AL..-4F
5/8"	27	5.5-6.0	4.5-4	5ERQ60...	5ELQ60...	0.64	2.1	3.1	YE5	YI5	AL..-5 (LH)

Partial Profile 60° (con't)

External

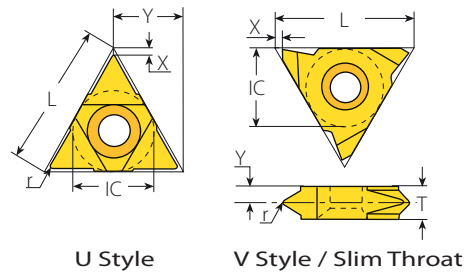
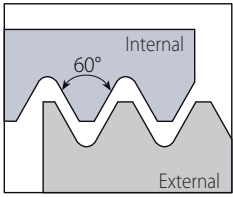

U Style



Insert Size		Pitch		Ordering Code		Dimensions mm			Anvil		Toolholder
IC	L mm	mm	tpi	RH+LH	r	X	Y	RH	LH		
1/2"U	22	5.5-8.0	4.5-3.25	4UEIU60...	0.30	0.6	11.0	YE4U	YI4U	AL...-4U (LH)	
5/8"U	27	6.5-9.0	4-2.75	5UEIU60...	0.37	1.0	13.7	YE5U	YI5U	AL...-5U (LH)	

Slim Throat



Insert Size		Pitch		Ordering Code		Dimensions mm					Toolholder
IC	L mm	mm	tpi	RH	LH	r	X	Y	T		
1/4"V	11	0.5-1.5	48-16	2VERA60...	2VELA60...	0.05	0.69	2.3	3.2	NL...-2V (LH)	
		0.5-1.5	48-16	3VERA60...	3VELA60...	0.05	1.10	2.7	3.6		
3/8"V	16	1.75-3.0	14-8	3VERG60...	3VELG60...	0.27	1.10	1.9	3.6	NL...-3V (LH)	
		0.5-3.0	48-8	3VERAG60...	3VELAG60...	0.08	1.10	1.9	3.6		
1/2"V	22	3.5-5.0	7-5	4VERN60...	4VELN60...	0.53	1.10	2.3	4.8	NL...-4V (LH)	

V Style



Insert Size		Pitch		Ordering Code		Dimensions mm					Toolholder
IC	L mm	mm	tpi	RH	LH	r	X	Y	T		
5/8"V	27	6.0-10.0	4-2.5	5VERV60...	5VELV60...	0.75	0.6	5.2	10	NL...-5V-10 (LH)	

Partial Profile 60°

External

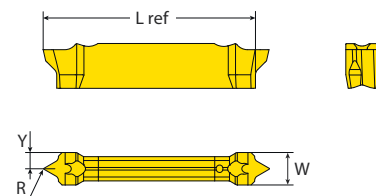
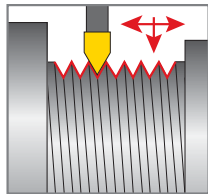
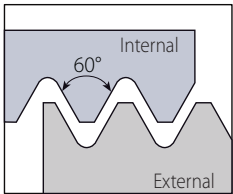

VG-Cut

VG-Cut





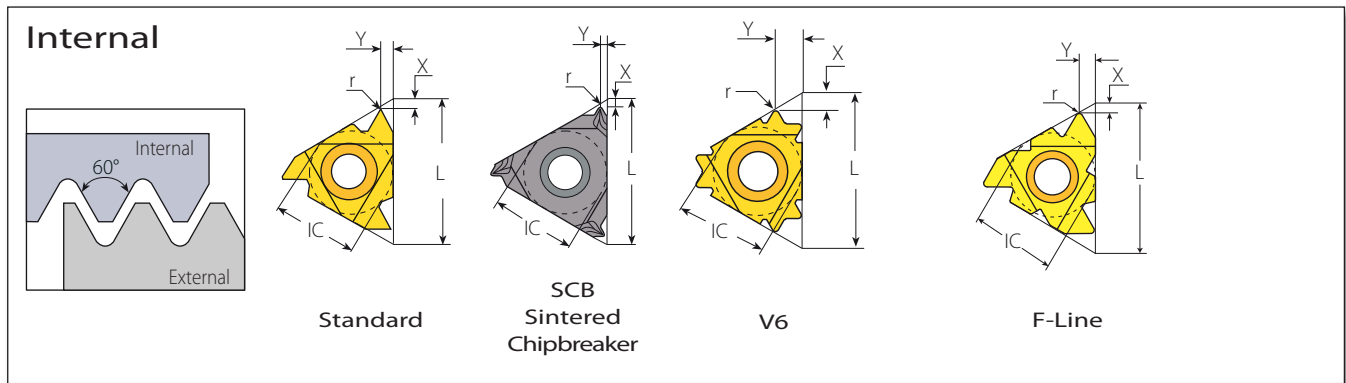

Pocket Size	Ordering Code	Dimensions mm					No. of Passes	Helix Deg	Min. Thread Diameter	Toolholder
		RH	W ref	Pitch mm	R	Y				
3	VGD3.0A60RH...	3.00	0.5-1.5	0.05	1.68	21.9	5 - 8	1.5°	Partial Profile A60	VGE...T12

Partial Profile 60° (con't)



Standard

	Insert Size		Pitch		Ordering Code		Dimensions mm			Anvil		Toolholder
	IC	L mm	mm	tpi	RH	LH	r	X	Y	RH	LH	
	1/4"	11	0.5-1.5	48-16	2IRA60...	2ILA60...	0.05	0.8	0.9	-	-	NVR...-2 (LH)
	1/4" SCB	11	0.5-1.5	48-16	2JIRA60...		0.05	0.6	0.8	-	-	NVR...-2
	3/8"	16	0.5-1.5	48-16	3IRA60...	3ILA60...	0.05	0.8	0.9	Y13	YE3	AVR...-3 (LH)
			1.75-3.0	14-8	3IRG60...	3ILG60...	0.16	1.2	1.7			
			0.5-3.0	48-8	3IRAG60...	3ILAG60...	0.05	1.2	1.7			
	3/8" V6	16	0.5-1.5	48-16	3JIRA60...		0.05	0.6	0.8	Y13	-	AVR...-3
			1.75-3.0	14-8	3JIRG60...		0.16	1.0	1.5			
			0.5-3.0	48-8	3JIRAG60...		0.05	0.9	1.5			
	1/2"	22	3.5-5.0	7-5	4IRN60...	4ILN60...	0.30	1.7	2.5	Y14	YE4	AVR...-4 (LH)
	1/2"F	23	3.5-5.0	7-5	4FIRN60...		0.3	1.7	2.5	Y14F	-	AVRC...-4F
	5/8"	27	5.5-6.0	4.5-4	5IRQ60...	5ILQ60...	0.30	1.8	2.7	Y15	YE5	AVR...-5 (LH)

Partial Profile 60° (con't)

Internal

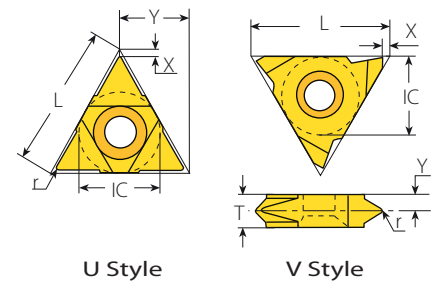
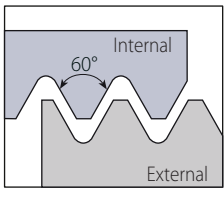

U Style

V Style

U Style



Insert Size		Pitch		Ordering Code	Dimensions mm			Anvil		
IC	L mm	mm	tpi	RH+LH	r	X	Y	RH	LH	Toolholder
1/2"U	22	5.5-8.0	4.5-3.25	4UEIU60...	0.30	0.6	11.0	YI4U	YE4U	AVR...-4U (LH)
5/8"U	27	6.5-9.0	4-2.75	5UEIU60...	0.37	1.0	13.7	YI5U	YE5U	AVR...-5U (LH)

V Style



Insert Size		Pitch		Ordering Code		Dimensions mm				
IC	L mm	mm	tpi	RH	LH	r	X	Y	T	Toolholder
5/8"V	27	6.0-10.0	4-2.5	5VIRV60...	5VILV60...	0.35	1.0	4.3	8	NVR...-5V (LH)

Partial Profile 60° (con't)

Mini-V



Mini-V



Insert Style	Pitch		Ordering Code	Dimensions mm						Helix Deg.	Toolholder
	tpi	mm		d	T	F	Y	r			
V08	48-32	0.5-0.75	V08THH60R...	6	3.8	4.20	0.5	0.03	1.5	.V08-...	
	24-20	1.0-1.25	V08THI60R...			4.46	0.8	0.10	2.5		
	16-14	1.5-1.75	V08THJ60R...			4.76	0.9	0.14	3		
V11	48-32	0.5-0.75	V11THH60R...	8	4.2	5.80	0.5	0.30	1.5	.V11-...	
	24-20	1.0-1.25	V11THI60R...			6.06	0.8	0.10	1.5		
	16-14	1.5-1.75	V11THJ60R...			5.61	0.9	0.14	3		
V14	48-16	0.5-1.5	V14THA60R...	9	5.7	9	0.9	0.05	1.5	.V14-...	
	14-8	1.75-3.0	V14THG60R...			1.7	0.16				
	48-8	0.5-3.0	V14THAG60R...			1.7	0.05				
V16	48-16	0.5-1.5	V16THA60R...	11	5.7	10.2	0.9	0.05	1.5	.V16-...	
	14-8	1.75-3.0	V16THG60R...			1.7	0.16				
	48-8	0.5-3.0	V16THAG60R...			1.7	0.05				

Partial Profile 60° (con't)

MINIPRO

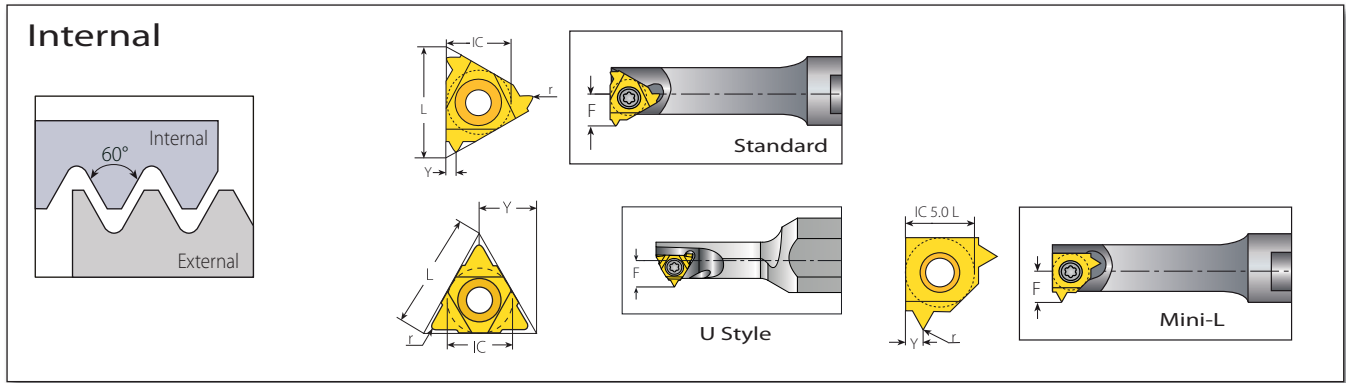

Mini-3 Standard



Insert Size		Pitch		Ordering Code		Dimensions mm			Min. Bore Dia.	Toolholder
IC mm	L mm	mm	tpi	RH	LH	r	Y	F	mm	
4.0	6	0.5-1.25	48-20	4.0KIRA60...	4.0KILA60...	0.05	0.6	3.7	6.35	.NVR.5-4.0K (LH)
5.0	8	0.5-1.5	48-16	5.0KIRA60...	5.0KILA60...	0.05	0.7	4.7	7.80	.NVRC 7-5.0K (LH)
6.0	10	0.5-1.5	48-16	6.0IRA60...		0.05	0.9	5.3	10.00	.NVR 1..-6.0

Left handed tool supplied by request (Example: 6.0ILA60...).

Mini-3 U Style



Insert Size		Pitch		Ordering Code		Dimensions mm			Min. Bore Dia.	Toolholder
IC mm	L mm	mm	tpi	RH+LH		r	Y	F	mm	
5.0U	8	1.75-2.0	14-11	5.0KUIB60...		0.16	4.0	5.8	9.0	.NVRC 8-5.0KU (LH)

Mini-L



Insert Size		Pitch		Ordering Code		Dimensions mm			Min. Bore Dia.	Toolholder
IC mm	mm	tpi		RH	LH	r	Y	F	mm	
5.0L	0.5-1.5	48-16		5LIRA60...		0.05	0.9	4.65	8.0	.NVR 10-5L

Left handed tool supplied by request (Example: 5LILA60...).

Partial Profile 60° (con't)

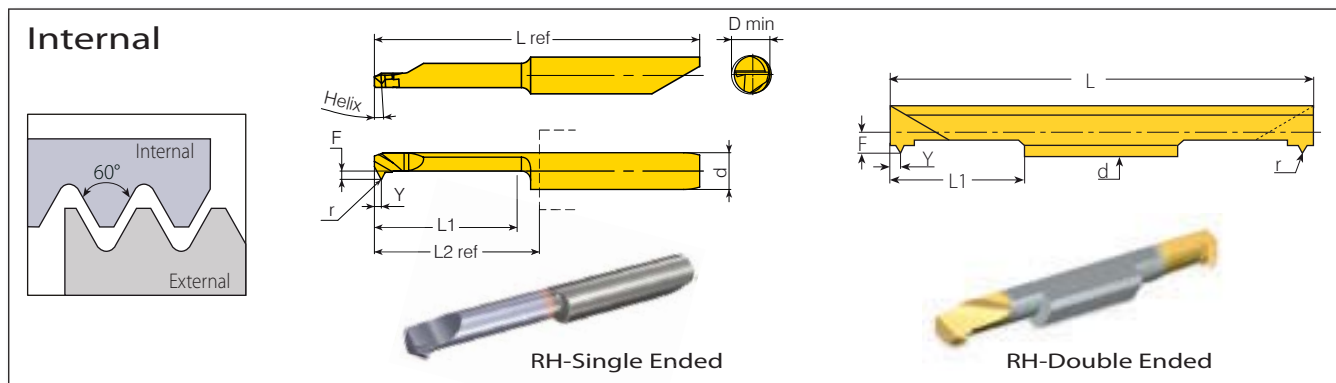
MINIPRO

Micro - Double Ended

Insert Dia.		Pitch		Ordering Code	Dimensions mm					Min. Bore Dia.	Toolholder
d mm	mm	tpi		RH	r	L1	L	F	Y	mm	
3.0	0.5-1.0	48-24		3.0SIRF60...	0.05	16	50	1.46	0.9	3.3	SMC..-3.0
4.0	0.5-1.0	48-24		4.0SIRF60...	0.05	16	50	1.96	0.9	4.3	SMC..-4.0
6.0	0.5-1.5	48-16		6.0SIRA60...	0.05	16	50	2.50	0.9	6.0	SMC..-6.0

Left handed tool supplied by request (Example: 6.0SILA60...).

Micro - Single Ended

microscope

Insert Dia.		Pitch		Ordering Code	Dimensions mm							Min. Bore Dia.	Toolholder
d mm	mm	tpi		RH/LH	Helix °	r	L1	F	Y	L2 ref*	L ref	D mm	
4.0	0.5-1.0	48-24		MS429THF60L16R/L...	3.5	0.03	16	0.9	0.9	18.4	35.4	3.2	MH...-4.0
	0.5-1.0	48-24		MS439THF60L16R/L...		0.03		1.9				4.2	
6.0	0.5-1.5	48-16		M659THA60L16R/L...		0.05	2.9	18.5	42.2	6.2	MH...-6.0		

* L2 Ref: Repeatability within +/-0.02.

Partial Profile 55°

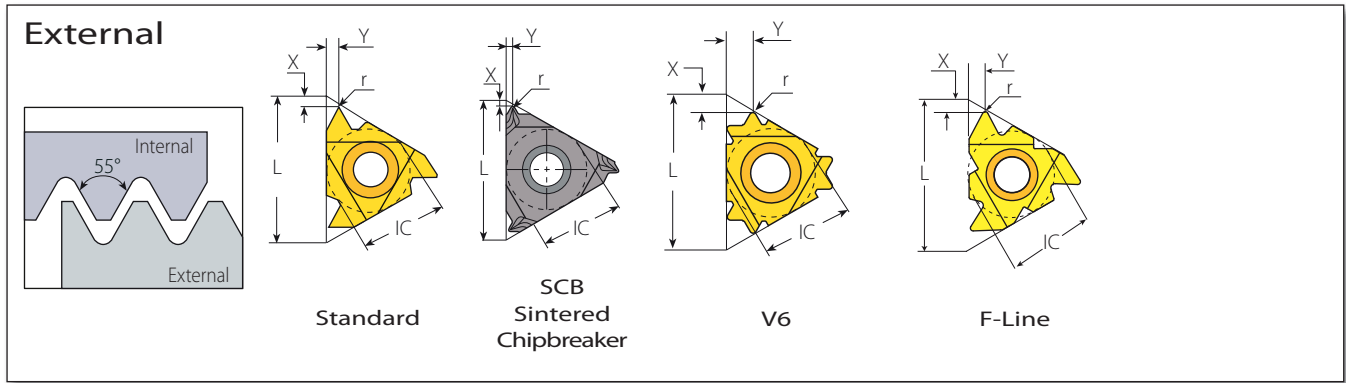

Standard



SCB



V6



F-LINE

	Insert Size		Pitch		Ordering Code		Dimensions mm			Anvil		Toolholder
	IC	L mm	mm	tpi	RH	LH	r	X	Y	RH	LH	
1/4"	11		0.5-1.5	48-16	2ERA55...	2ELA55...	0.05	0.8	0.9	-	-	NL..-2 (LH)
			0.5-1.5	48-16	3ERA55...	3ELA55...	0.05	0.8	0.9			
	3/8"	16	1.75-3.0	14-8	3ERG55...	3ELG55...	0.21	1.2	1.7	YE3	YI3	AL..-3 (LH)
0.5-3.0			48-8	3ERAG55...	3ELAG55...	0.07	1.2	1.7				
3/8" SCB	16		0.5-1.5	48-16	3JERA55...		0.05	0.6	0.8			
			1.75-3.0	14-8	3JERG55...		0.21	1.1	1.5	YE3	-	AL..-3
			0.5-3.0	48-8	3JERAG55...		0.07	0.9	1.5			
3/8" V6	16		-	48-14	3ERS55-6C...		0.05	1.8	2.8	YE3-6C	-	AL..-3
1/2"	22		3.5-5.0	7-5	4ERN55...	4ELN55...	0.43	1.7	2.5	YE4	YI4	AL..-4 (LH)
1/2" F	23		3.5-5.0	7-5	4FERN55...		0.43	1.7	2.5	YE4F	-	AL...-4F
5/8"	27		5.5-6.0	4.5-4	5ERQ55...	5ELQ55...	0.60	2.0	2.9	YE5	YI5	AL..-5 (LH)

Partial Profile 55° (con't)

External



U Style V Style / Slim Throat

U Style



Insert Size	Pitch		Ordering Code		Dimensions mm			Anvil		Toolholder	
	IC	L mm	mm	tpi	RH+LH	r	X	Y	RH		LH
1/2"U	22		5.5-8.0	4.5-3.25	4UEIU55...	0.60	0.9	11.0	YE4U	YI4U	AL..-4U (LH)
5/8"U	27		6.5-9.0	4-2.75	5UEIU55...	0.80	1.2	13.7	YE5U	YI5U	AL..-5U (LH)

Slim Throat



Insert Size	Pitch		Ordering Code		Dimensions mm					Toolholder	
	IC	L mm	mm	tpi	RH	LH	r	X	Y		T
1/4"V	11	16	0.5-1.5	48-16	2VERA55...	2VELA55...	0.05	0.8	2.7	3.2	NL..-2V (LH)
			0.5-1.5	48-16	3VERA55...	3VELA55...	0.05	1.1	2.7	3.6	
3/8"V	16	16	1.75-3.0	14-8	3VERG55...	3VELG55...	0.21	1.1	1.9	3.6	NL..-3V (LH)
			0.5-3.0	48-8	3VERAG55...	3VELAG55...	0.07	1.1	1.9	3.6	
1/2"V	22		3.5-5.0	7-5	4VERN55...	4VELN55...	0.43	1.1	2.3	4.8	NL..-4V (LH)

V Style



Insert Size	Pitch		Ordering Code		Dimensions mm					Toolholder	
	IC	L mm	mm	tpi	RH	LH	r	X	Y		T
5/8"V	27		6.0-9.0	4-2.75	5VERV55...	5VELV55...	0.70	1.0	4.3	8	NL..-5V-8 (LH)

Partial Profile 55°

External





VG-Cut

VG-Cut



Pocket Size	Ordering Code	Dimensions mm					No. of Passes	Helix	Min. Thread Diameter	Toolholder	
		RH	W ref	Pitch tpi	R	Y					L ref
3	VGD3.0A55RH...		3.00	48-16	0.05	1.68	21.9	5 - 8	1.5°	Partial Profile A55	VGE...T12

Partial Profile 55° (con't)

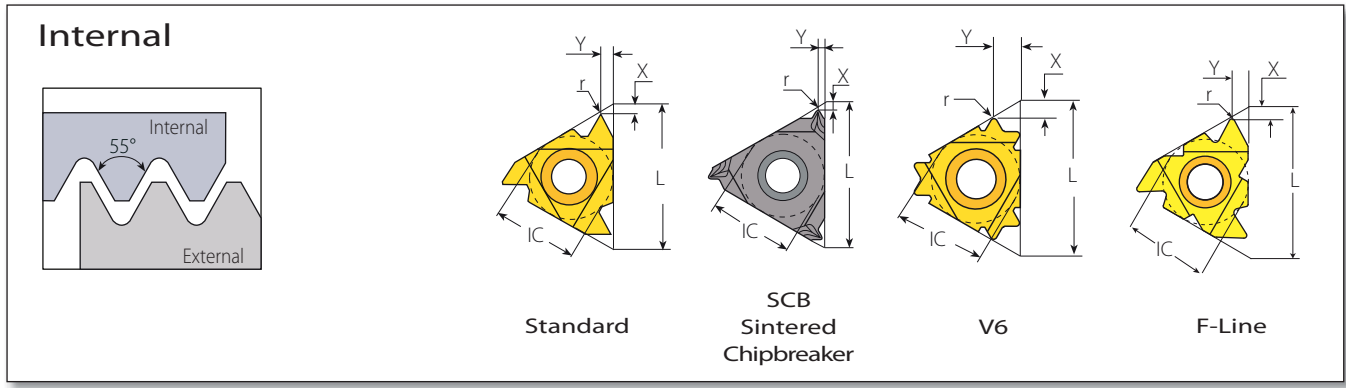

Standard



Insert Size		Pitch		Ordering Code		Dimensions mm			Anvil		
IC	L mm	mm	tpi	RH	LH	r	X	Y	RH	LH	Toolholder
1/4"	11	0.5-1.5	48-16	2IRA55...	2ILA55...	0.05	0.8	0.9	-	-	NVR...-2 (LH)
1/4" SCB	11	0.5-1.5	48-16	2JIRA55...		0.05	0.6	0.8	-	-	NVR...-2



3/8"	16	0.5-1.5	48-16	3IRA55...	3ILA55...	0.05	0.8	0.9	YI3	YE3	AVR...-3 (LH)
		1.75-3.0	14-8	3IRG55...	3ILG55...	0.21	1.2	1.7			
		0.5-3.0	48-8	3IRAG55...	3ILAG55...	0.07	1.2	1.7			



3/8" SCB	16	0.5-1.5	48-16	3JIRA55...		0.05	0.6	0.8	YI3	-	AVR...-3
		1.75-3.0	14-8	3JIRG55...		0.21	1.1	1.5			
		0.5-3.0	48-8	3JIRAG55...		0.07	0.9	1.5			
3/8" V6	16	-	48-16	3IRS55-6C...		0.05	1.6	2.6	YI3-6C	-	AVR...-3 NVRC...-3 206/...



1/2"	22	3.5-5.0	7-5	4IRN55...	4ILN55...	0.43	1.7	2.5	YI4	YE4	AVR...-4 (LH)
1/2"F	23	3.5-5.0	7-5	4FIRN55...		0.43	1.7	2.5	YI4F	-	AVRC...-4F
5/8"	27	5.5-6.0	4.5-4	5IRQ55...	5ILQ55...	0.60	2.0	2.9	YI5	YE5	AVR...-5 (LH)

Partial Profile 55° (con't)

Internal



U Style **V Style**

U Style



Insert Size	Pitch			Ordering Code	Dimensions mm			Anvil		
	L mm	mm	tpi		r	X	Y	RH	LH	Toolholder
1/2"U	22	5.5-8.0	4.5-3.25	RH+LH 4UEIU55...	0.60	0.9	11.0	YI4U	YE4U	AVR...-4U (LH)
5/8"U	27	6.5-9.0	4-2.75	5UEIU55...	0.80	1.2	13.7	YI5U	YE5U	AVR...-5U (LH)

V Style



Insert Size	Pitch			Ordering Code		Dimensions mm				
	L mm	mm	tpi	RH	LH	r	X	Y	T	Toolholder
5/8"V	27	6.0-9.0	4-2.75	5VIRV55...	5VILV55...	0.70	1.0	4.3	8	NVR...-5V (LH)

Partial Profile 55° (con't)

Mini-V

Internal

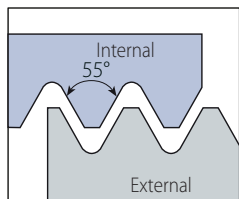
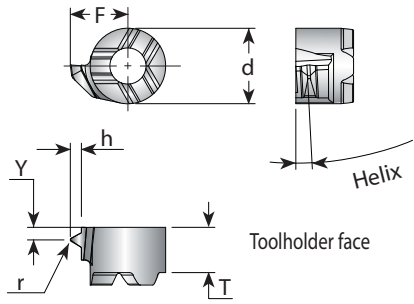
Mini-V



Insert Style	Pitch		Ordering Code	Dimensions mm						Helix Deg.	Toolholder
	tpi	mm		RH	d	T	F	Y	r		
V14	48-16	0.5-1.5	V14THA55R...				0.9	0.05			
	14-8	1.75-3.0	V14THG55R...	9	5.7	9	1.7	0.21	1.5	.V14-...	
	48-8	0.5-3.0	V14THAG55R...				1.7	0.07			
V16	48-16	0.5-1.5	V16THA55R...				0.9	0.07			
	14-8	1.75-3.0	V16THG55R...	11	5.7	10.2	1.7	0.25	1.5	.V16-...	
	48-8	0.5-3.0	V16THAG55R...				1.7	0.07			

Partial Profile 55° (con't)

MINIPRO

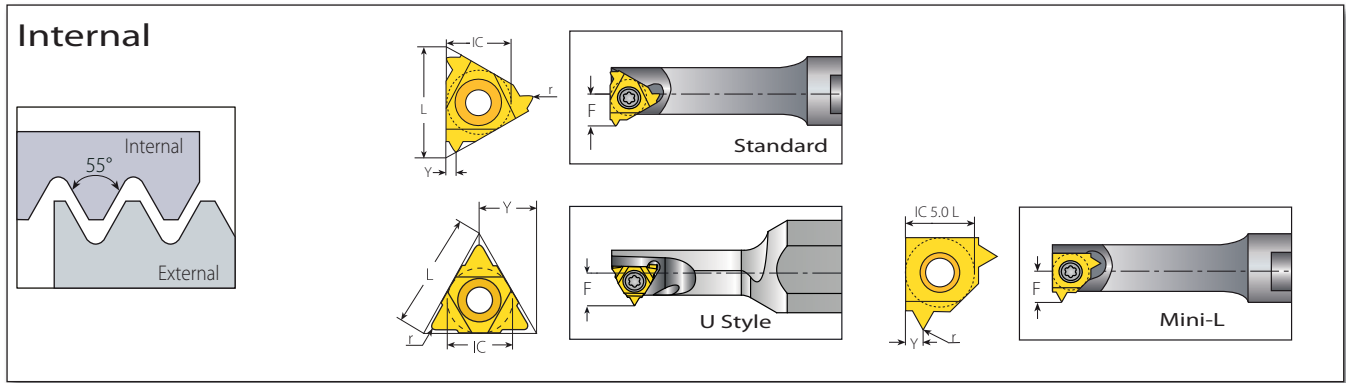

Mini-3 Standard



Insert Size		Pitch		Ordering Code		Dimensions mm			Min. Bore Dia.	Toolholder
IC mm	L mm	mm	tpi	RH	LH	r	Y	F	mm	
4.0	6	0.5-1.25	48-20	4.0KIRA55...	4.0KILA55...	0.05	0.6	3.8	6.45	.NVR.5-4.0K (LH)
5.0	8	0.5-1.5	48-16	5.0KIRA55...	5.0KILA55...	0.05	0.7	4.7	7.80	.NVRC 7-5.0K (LH)
6.0	10	0.5-1.50	48-16	6.0IRA55...		0.05	0.9	5.3	10.00	.NVR 1..-6.0

Left handed tool supplied by request (Example: 6.0ILA55..).

Mini-3 U Style



Insert Size		Pitch		Ordering Code		Dimensions mm			Min. Bore Dia.	Toolholder
IC mm	L mm	mm	tpi	RH+LH		r	Y	F	mm	
5.0U	8	1.75-2.0	14-11	5.0KUIB55...		0.21	4.0	5.7	9.0	.NVRC 8-5.0KU (LH)

Mini-L



Insert Size		Pitch		Ordering Code		Dimensions mm			Min. Bore Dia.	Toolholder
IC mm	mm	tpi		RH	LH	r	Y	F	mm	
5.0L	0.5-1.5	48-16		5LIRA55...		0.05	0.9	4.65	8.0	.NVR 10.-5L

Left handed tool supplied by request (Example: 5LILA55..).

Partial Profile 55° (con't)

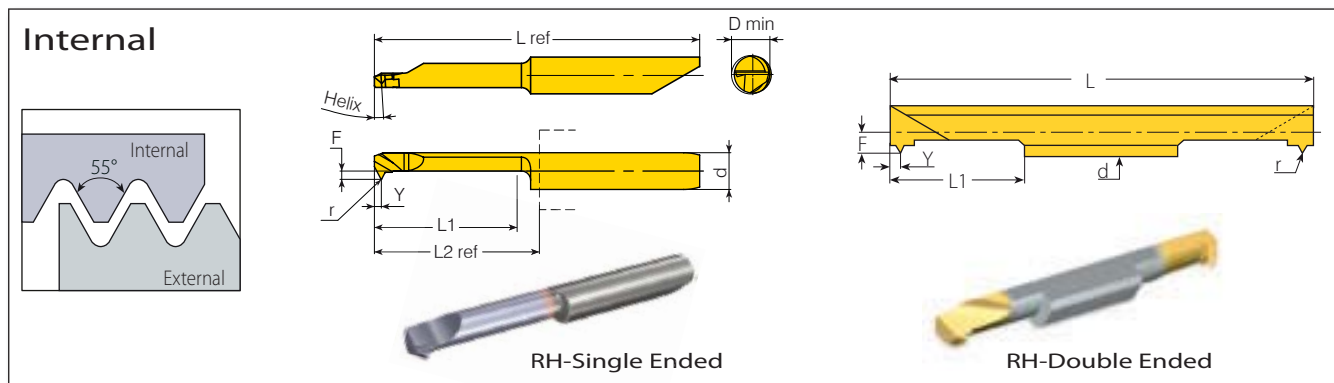
MINIPRO

Micro - Double Ended

Insert Dia.	Pitch	Ordering Code	Dimensions mm							Min. Bore Dia.	
d mm	mm	tpi	RH	r	L1	L	F	Y	mm	Toolholder	
3.0	0.5-1.0	48-24	3.0SIRF55...	0.05	16	50	1.46	0.9	3.3	SMC..-3.0	
4.0	0.5-1.0	48-24	4.0SIRF55...	0.05	16	50	1.96	0.9	4.3	SMC..-4.0	
6.0	0.5-1.5	48-16	6.0SIRA55...	0.05	16	50	2.50	0.9	6.0	SMC..-6.0	

Left handed tool supplied by request (Example: 6.0SILA55...).

Micro - Single Ended

microscope

Insert Dia..	Pitch	Ordering Code	Dimensions mm								Min. Bore Dia.	
d mm	mm	tpi	RH/LH	Helix °	r	L1	F	Y	L2 ref*	L ref	D mm	Toolholder
4.0	0.5-1.0	48-24	MS429THF55L16R/L...	3.5	0.05	16	0.9	0.75	18.4	35.4	3.2	MH...-4.0
	0.5-1.0	48-24	MS439THF55L16R/L...		0.05		1.9				4.2	
6.0	0.5-1.5	48-16	M659THA55L16R/L...		0.06		2.9	0.9	18.5	42.2	6.2	MH...-6.0

* L2 Ref: Repeatability within +/-0.02.

ISO Metric

External

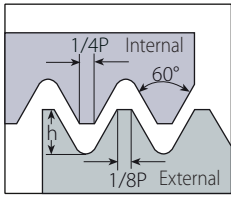

Defined by: R262 (DIN 13)
Tolerance class: 6g/6H

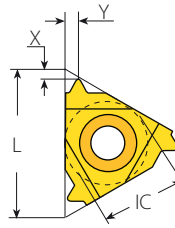

Standard

Standard

Insert Size		Pitch	Ordering Code		Dimensions mm			Anvil		Toolholder
IC	L mm	mm	RH	LH	h min	X	Y	RH	LH	
1/4"	11	0.25	2ER0.25ISO...	2EL0.25ISO...	0.14	0.4	0.2	-	-	NL..-2 (LH)
		0.3	2ER0.3ISO...	2EL0.3ISO...	0.19	0.7	0.3			
		0.35	2ER0.35ISO...	2EL0.35ISO...	0.21	0.8	0.4			
		0.4	2ER0.4ISO...	2EL0.4ISO...	0.25	0.7	0.4			
		0.45	2ER0.45ISO...	2EL0.45ISO...	0.28	0.7	0.4			
		0.5	2ER0.5ISO...	2EL0.5ISO...	0.31	0.6	0.4			
		0.6	2ER0.6ISO...	2EL0.6ISO...	0.37	0.6	0.6			
		0.7	2ER0.7ISO...	2EL0.7ISO...	0.43	0.6	0.6			
		0.75	2ER0.75ISO...	2EL0.75ISO...	0.46	0.6	0.6			
		0.8	2ER0.8ISO...	2EL0.8ISO...	0.49	0.6	0.6			
		1.0	2ER1.0ISO...	2EL1.0ISO...	0.61	0.7	0.7			
		1.25	2ER1.25ISO...	2EL1.25ISO...	0.77	0.8	0.9			
		1.5	2ER1.5ISO...	2EL1.5ISO...	0.92	0.8	1.0			
1.75	2ER1.75ISO...	2EL1.75ISO...	1.07	0.8	1.1					
3/8"	16	0.25	3ER0.25ISO...	3EL0.25ISO...	0.14	0.4	0.2	YE3	YI3	AL..-3 (LH)
		0.3	3ER0.3ISO...	3EL0.3ISO...	0.17	0.73	0.29			
		0.35	3ER0.35ISO...	3EL0.35ISO...	0.21	0.8	0.4			
		0.4	3ER0.4ISO...	3EL0.4ISO...	0.25	0.7	0.4			
		0.45	3ER0.45ISO...	3EL0.45ISO...	0.28	0.7	0.4			
		0.5	3ER0.5ISO...	3EL0.5ISO...	0.31	0.6	0.4			
		0.6	3ER0.6ISO...	3EL0.6ISO...	0.37	0.6	0.6			
		0.7	3ER0.7ISO...	3EL0.7ISO...	0.43	0.6	0.6			
		0.75	3ER0.75ISO...	3EL0.75ISO...	0.46	0.6	0.6			
		0.8	3ER0.8ISO...	3EL0.8ISO...	0.49	0.6	0.6			
		1.0	3ER1.0ISO...	3EL1.0ISO...	0.61	0.7	0.7			
		1.25	3ER1.25ISO...	3EL1.25ISO...	0.77	0.8	0.9			
		1.5	3ER1.5ISO...	3EL1.5ISO...	0.92	0.8	1.0			
		1.75	3ER1.75ISO...	3EL1.75ISO...	1.07	0.9	1.2			
		2.0	3ER2.0ISO...	3EL2.0ISO...	1.23	1.0	1.3			
		2.5	3ER2.5ISO...	3EL2.5ISO...	1.53	1.1	1.5			
3.0	3ER3.0ISO...	3EL3.0ISO...	1.84	1.2	1.6					
3.5	3ER3.5ISO...	3EL3.5ISO...	2.15	1.6	1.9					



ISO Metric (con't)

External

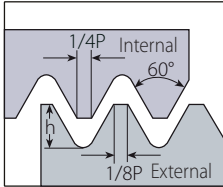

Defined by: R262 (DIN 13)
Tolerance class: 6g/6H

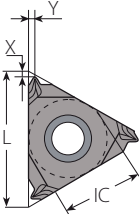

SCB
Sintered
Chipbreaker

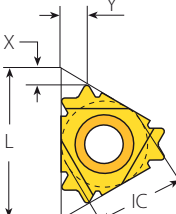

V6

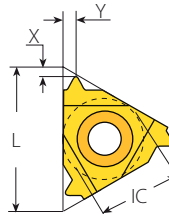

Standard

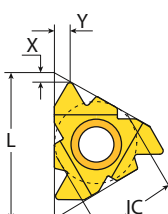

F-Line

Standard



Insert Size		Pitch	Ordering Code		Dimensions mm			Anvil		Toolholder					
IC	L mm	mm	RH	LH	h min	X	Y	RH	LH						
3/8" SCB	16	0.5	3JER0.5ISO...		0.31	1.2	0.5	YE3	-	AL...-3					
		0.75	3JER0.75ISO...		0.46	1.2	0.5								
		0.8	3JER0.8ISO...		0.49	1.2	0.5								
		1.0	3JER1.0ISO...		0.61	0.7	0.8								
		1.25	3JER1.25ISO...		0.77	0.7	0.8								
		1.5	3JER1.5ISO...		0.92	0.7	0.8								
		1.75	3JER1.75ISO...		1.07	1.2	1.5								
		2.0	3JER2.0ISO...		1.23	1.2	1.5								
		2.5	3JER2.5ISO...		1.53	1.2	1.5								
		3.0	3JER3.0ISO...		1.84	1.3	1.5								
3/8" V6	16	0.5	3ER0.5ISO-6C...		0.31	2.2	1.8	YE3-6C	-	AL...-3					
		0.75	3ER0.75ISO-6C...		0.46	2.0	1.8								
		0.8	3ER0.8ISO-6C...		0.49	2.0	1.9								
		1.0	3ER1.0ISO-6C...		0.61	1.9	2.0								
		1.25	3ER1.25ISO-6C...		0.77	1.8	2.1								
		1.5	3ER1.5ISO-6C...		0.92	1.9	2.4								
		1.75	3ER1.75ISO-6C...		1.07	1.8	2.6								
		2.0	3ER2.0ISO-6C...		1.23	1.9	2.8								
		1/2"	22	3.5	4ER3.5ISO...	4EL3.5ISO...	2.15				1.6	2.3	YE4	YI4	AL...-4 (LH)
				4.0	4ER4.0ISO...	4EL4.0ISO...	2.45				1.6	2.3			
4.5	4ER4.5ISO...			4EL4.5ISO...	2.76	1.7	2.4								
5.0	4ER5.0ISO...			4EL5.0ISO...	3.07	1.7	2.5								
5.5	4ER5.5ISO...			4EL5.5ISO...	3.37	1.9	2.7								
6.0	4ER6.0ISO...			4EL6.0ISO...	3.68	1.8	2.7								
1/2" F LINE	23	3.5	4FER3.5ISO...		2.15	1.6	2.3	YE4F	-	AL...-4F					
		4.0	4FER4.0ISO...		2.45	1.6	2.3								
		4.5	4FER4.5ISO...		2.76	1.7	2.4								
		5.0	4FER5.0ISO...		3.07	1.7	2.5								
		5.5	4FER5.5ISO...		3.37	1.9	2.7								
5/8"	27	5.5	5ER5.5ISO...	5EL5.5ISO...	3.37	1.9	2.7	YE5	YI5	AL...-5 (LH)					
		6.0	5ER6.0ISO...	5EL6.0ISO...	3.68	2.0	2.9								

ISO Metric (con't)

External

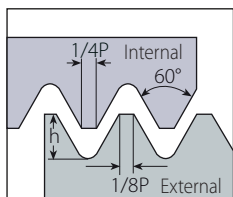

Defined by: R262 (DIN 13)
Tolerance class: 6g/6H

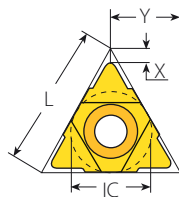

U Style

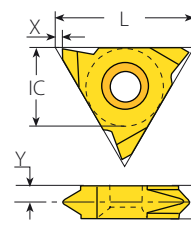

V Style / Slim Throat

U Style



Insert Size		Pitch	Ordering Code		Dimensions mm			Anvil		Toolholder
IC	L mm	mm	RH+LH	h min	X	Y	RH	LH		
1/2"U	22	5.0	4UE5.0ISO...	3.07	2.2	11.0	YE4U	YI4U	AL...-4U (LH)	
		5.5	4UE5.5ISO...	3.37	2.3	11.0				
		6.0	4UE6.0ISO...	3.68	2.6	11.0				
5/8"U	27	8.0	5UE8.0ISO...	4.91	2.4	13.7	YE5U	YI5U	AL...-5U (LH)	

Slim Throat



Insert Size		Pitch	Ordering Code		Dimensions mm				Toolholder
IC	L mm	mm	RH	LH	h min	X	Y	T	
1/4"V	11	0.75	2VER0.75ISO...	2VEL0.75ISO...	0.46	0.7	2.6	3.2	NL...-2V (LH)
		1.0	2VER1.0ISO...	2VEL1.0ISO...	0.61	0.7	2.5	3.2	
		1.5	2VER1.5ISO...	2VEL1.5ISO...	0.92	0.7	2.2	3.2	
		1.75	2VER1.75ISO...	2VEL1.75ISO...	1.07	0.7	2.1	3.2	
		2.0	2VER2.0ISO...	2VEL2.0ISO...	1.23	0.7	1.9	3.2	
3/8"V	16	0.35	3VER0.35ISO...	3VEL0.35ISO...	0.20	1.1	3.25	3.6	NL...-3V (LH)
		0.4	3VER0.4ISO...	3VEL0.4ISO...	0.25	1.1	3.20	3.6	
		0.5	3VER0.5ISO...	3VEL0.5ISO...	0.31	1.1	3.0	3.6	
		0.75	3VER0.75ISO...	3VEL0.75ISO...	0.46	1.1	3.0	3.6	
		0.8	3VER0.8ISO...	3VEL0.8ISO...	0.49	1.1	3.0	3.6	
		1.0	3VER1.0ISO...	3VEL1.0ISO...	0.61	1.1	2.9	3.6	
		1.25	3VER1.25ISO...	3VEL1.25ISO...	0.77	1.1	2.7	3.6	
		1.5	3VER1.5ISO...	3VEL1.5ISO...	0.92	1.1	2.6	3.6	
		1.75	3VER1.75ISO...	3VEL1.75ISO...	1.07	1.1	2.45	3.6	
		2.0	3VER2.0ISO...	3VEL2.0ISO...	1.23	1.1	2.3	3.6	
		2.5	3VER2.5ISO...	3VEL2.5ISO...	1.53	1.1	2.1	3.6	
3.0	3VER3.0ISO...	3VEL3.0ISO...	1.84	1.1	2.0	3.6			

V Style



Insert Size		Pitch	Ordering Code		Dimensions mm				Toolholder	
IC	L mm	mm	RH	LH	h min	X	Y	T		
5/8"V	27	5.5	5VER5.5ISO...	5VEL5.5ISO...	3.37	1.0	3.3	6	NL...-5V-6 (LH)	
		6.0	5VER6.0ISO...	5VEL6.0ISO...	3.68	1.0	3.3	6		
		8.0	5VER8.0ISO...	5VEL8.0ISO...	4.91	1.0	4.3	8		NL...-5V-8 (LH)
		10.0	5VER10.0ISO...	5VEL10.0ISO...	6.13	1.0	5.2	10		NL...-5V-10 (LH)

ISO Metric (con't)

External

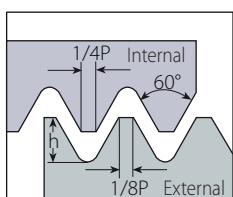

Defined by: R262 (DIN 13)
Tolerance class: 6g/6H

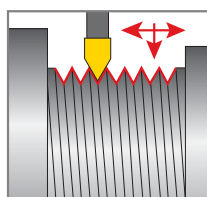

RS/LS Varied range of threading standards for machining between shoulders and close to spindle.

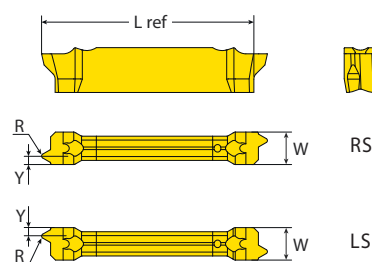

VG-Cut



Pocket Size	Ordering Code	Dimensions mm					No. of Passes	Helix	Min. Thread Diameter	Toolholder
		RH	W ref	Pitch mm	h min	Y				
3	VGD3.0ISO0.50RH-RS/LS...		0.50	0.31	0.53		5 - 7		M 3x0.5	VGE...T12
	VGD3.0ISO0.75RH-RS/LS...		0.75	0.46	0.64		5 - 8		M 5x0.75	
	VGD3.0ISO1.00RH-RS/LS...		1.00	0.61	0.74		5 - 9		M 6x1	
	VGD3.0ISO1.25RH-RS/LS...	3.00	1.25	0.77	0.85	21.9	6 - 10	2.5°	M 8x1.25	
	VGD3.0ISO1.50RH-RS/LS...		1.50	0.92	1.10		7 - 12		M10x1.5 Coarse	
	VGD3.0ISO1.75RH-RS/LS...		1.75	1.07	1.20		8 - 14		M12x1.75 Coarse	
	VGD3.0ISO2.00RH-RS/LS...		2.00	1.23	1.30		9 - 14		M16x2.0 Coarse	

LH Helix threads available upon request.

ISO Metric (con't)

MEGALINE

External

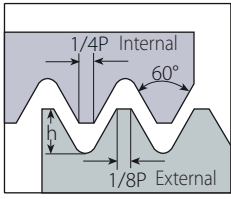

Defined by: R262 (DIN 13)
Tolerance class: 6g/6H

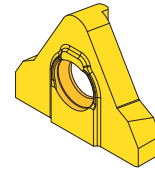
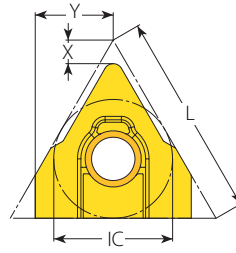

Mega Line

External





Insert Size		Pitch	Ordering Code	Dimensions mm			Number of Passes	
IC	L mm	mm	RH	h min	X	Y	0.07mm–Min. Depth of Cut (On radius)	0.15mm–Max. Depth of Cut (On radius)
5/8" MG	27	12.0	5MGER12.0ISO...	7.36	4.08	11.3	105	49
		16.0	5MGER16.0ISO...	9.82	4.66		140	66
		18.0	5MGER18.0ISO...	11.04	4.95		158	74
		20.0	5MGER20.0ISO...	12.27	5.24		175	82
		25.0	5MGER25.0ISO...	15.34	4.46		219	102

Recommended thread infeed method for Mega Line: Flank or Modified Flank 1°.

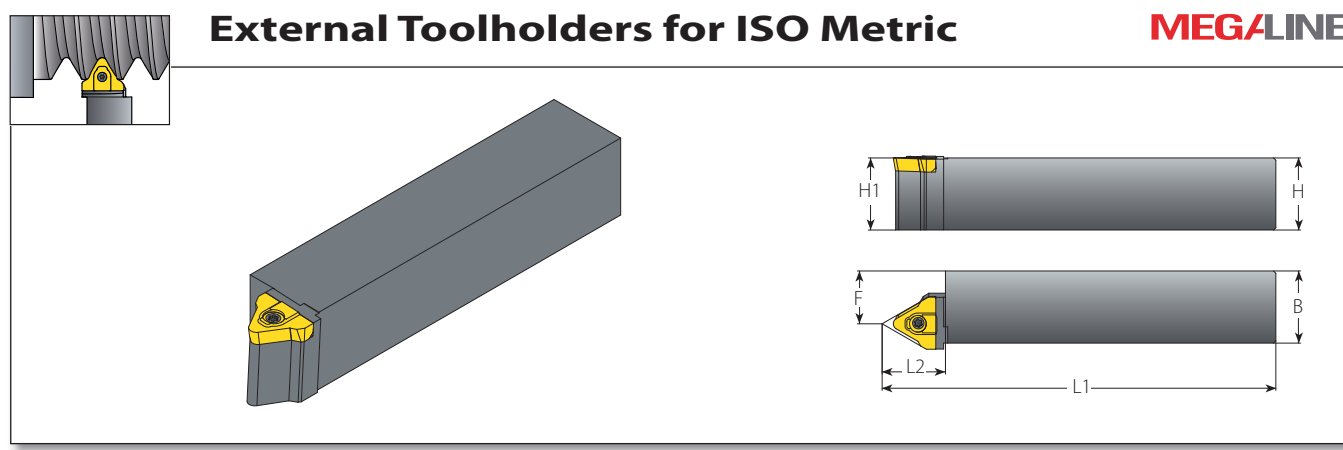
External Toolholders for ISO Metric



External							Spare Parts	
Insert	Ordering Code	Dimensions mm				Thread Diameter Range (Min.)		
		RH	H=B=H1	F	L1			
5MGER12.0ISO...	NL25-5MG12ISO	25	16.5	155	22	M43x12	S5MG	K6T
	NL32-5MG12ISO	32	23.5	175				
	NL40-5MG12ISO	40	31.5	205				
5MGER16.0ISO...	NL25-5MG16ISO	25	16.5	155	22	M57x16		
	NL32-5MG16ISO	32	23.5	175				
	NL40-5MG16ISO	40	31.5	205				
5MGER18.0ISO...	NL25-5MG18ISO	25	16.5	155	22	M65x18		
	NL32-5MG18ISO	32	23.5	175				
	NL40-5MG18ISO	40	31.5	205				
5MGER20.0ISO...	NL25-5MG20ISO	25	16.5	155	22	M72x20		
	NL32-5MG20ISO	32	23.5	175				
	NL40-5MG20ISO	40	31.5	205				
5MGER25.0ISO...	NL25-5MG25ISO	25	16.5	155	22	M90x25		
	NL32-5MG25ISO	32	23.5	175				
	NL40-5MG25ISO	40	31.5	205				

Recommended thread infeed method for Mega Line: Flank or Modified Flank 1°.

ISO Metric (con't)

External

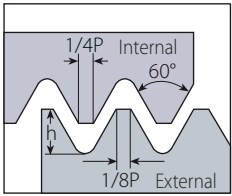

Defined by: R262 (DIN 13)
Tolerance class: 6g/6H

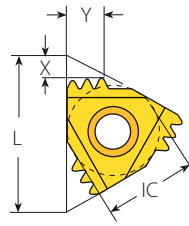

M+ Style

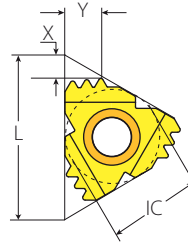

F-Line M+

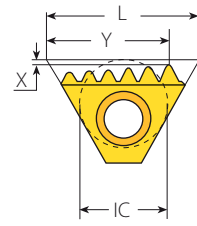

T+ Style

M+ Style



Insert Size		Pitch	Teeth	Ordering Code	Dimensions mm			Anvil	
IC	L mm	mm		RH	h min	X	Y	RH	Toolholder
3/8"	16	1.0	3	3ER1.0ISO3M+...	0.61	1.8	2.6	YE3M	AL...-3
		1.5	2	3ER1.5ISO2M+...	0.92	1.6	2.4		
		2.0	2	3ER2.0ISO2M+...	1.23	2.1	3.1		
1/2"	22	1.5	3	4ER1.5ISO3M+...	0.92	2.5	3.8	YE4M	AL...-4
		2.0	2	4ER2.0ISO2M+...	1.23	2.1	3.1		
		2.0	3	4ER2.0ISO3M+...	1.23	3.2	5.1		
		2.5	2	4ER2.5ISO2M+...	1.53	2.5	3.9		
1/2"F	23	2.0	2	4FER2.0ISO2M+...	1.23	2.1	3.1	YE4M2F	AL...-4MF
		2.0	3	4FER2.0ISO3M+...	1.23	3.2	5.1	YE4M3F	
5/8"	27	3.0	2	5ER3.0ISO2M+...	1.84	3.0	4.7	YE5M	AL...-5M



F LINE

T+ Style



Insert Size		Pitch	Teeth	Ordering Code	Dimensions mm			Anvil	
IC	L mm	mm		RH	h min	X	Y	RH	Toolholder
1/2"T	22	1.5	8	4ER1.5ISO8T+...	0.92	0.2	12.4	Y4T	AL...-4T
		2.0	8	4ER2.0ISO8T+...	1.23	0.2	17.5		



ISO Metric (con't)

Internal

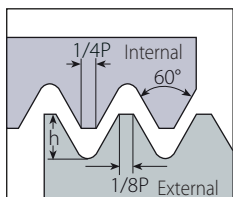

Defined by: R262 (DIN 13)
Tolerance class: 6g/6H

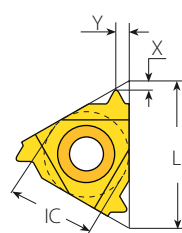

Standard

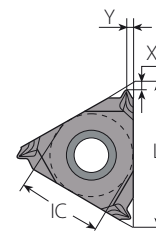

SCB
Sintered
Chipbreaker

Standard



1/4"

11



SCB

1/4"
SCB

11



3/8"

16

Insert Size		Pitch	Ordering Code		Dimensions mm			Anvil		Toolholder
IC	L mm	mm	RH	LH	h min	X	Y	RH	LH	
1/4"	11	0.35	2IR0.35ISO...	2IL0.35ISO...	0.20	0.8	0.3	-	-	NVR...-2 (LH)
		0.4	2IR0.4ISO...	2IL0.4ISO...	0.23	0.8	0.4			
		0.45	2IR0.45ISO...	2IL0.45ISO...	0.26	0.8	0.4			
		0.5	2IR0.5ISO...	2IL0.5ISO...	0.29	0.6	0.4			
		0.6	2IR0.6ISO...	2IL0.6ISO...	0.35	0.6	0.6			
		0.7	2IR0.7ISO...	2IL0.7ISO...	0.40	0.6	0.6			
		0.75	2IR0.75ISO...	2IL0.75ISO...	0.43	0.6	0.6			
		0.8	2IR0.8ISO...	2IL0.8ISO...	0.46	0.6	0.6			
		1.0	2IR1.0ISO...	2IL1.0ISO...	0.58	0.6	0.7			
		1.25	2IR1.25ISO...	2IL1.25ISO...	0.72	0.8	0.9			
		1.5	2IR1.5ISO...	2IL1.5ISO...	0.87	0.8	1.0			
		1.75	2IR1.75ISO...	2IL1.75ISO...	1.01	0.9	1.1			
		2.0	2IR2.0ISO...	2IL2.0ISO...	1.15	0.9	1.1			
1/4" SCB	11	0.5	2JIR0.5ISO...		0.29	1.2	0.5	-	-	NVR...-2
		0.75	2JIR0.75ISO...		0.43	1.2	0.5			
		0.8	2JIR0.8ISO...		0.46	1.2	0.5			
		1.0	2JIR1.0ISO...		0.58	0.7	0.8			
		1.25	2JIR1.25ISO...		0.72	0.7	0.8			
3/8"	16	0.35	3IR0.35ISO...	3IL0.35ISO...	0.20	0.8	0.3	YI3	YE3	AVR...-3 (LH)
		0.4	3IR0.4ISO...	3IL0.4ISO...	0.23	0.8	0.4			
		0.45	3IR0.45ISO...	3IL0.45ISO...	0.26	0.8	0.4			
		0.5	3IR0.5ISO...	3IL0.5ISO...	0.29	0.6	0.4			
		0.6	3IR0.6ISO...	3IL0.6ISO...	0.35	0.6	0.6			
		0.7	3IR0.7ISO...	3IL0.7ISO...	0.40	0.6	0.6			
		0.75	3IR0.75ISO...	3IL0.75ISO...	0.43	0.6	0.6			
		0.8	3IR0.8ISO...	3IL0.8ISO...	0.46	0.6	0.6			
		1.0	3IR1.0ISO...	3IL1.0ISO...	0.58	0.6	0.7			
		1.25	3IR1.25ISO...	3IL1.25ISO...	0.72	0.8	0.9			
		1.5	3IR1.5ISO...	3IL1.5ISO...	0.87	0.8	1.0			
		1.75	3IR1.75ISO...	3IL1.75ISO...	1.01	0.9	1.2			
		2.0	3IR2.0ISO...	3IL2.0ISO...	1.15	1.0	1.3			
2.5	3IR2.5ISO...	3IL2.5ISO...	1.44	1.1	1.5					
3.0	3IR3.0ISO...	3IL3.0ISO...	1.73	1.1	1.5					
3.5	3IR3.5ISO...	3IL3.5ISO...	2.02	1.2	1.5					

ISO Metric (con't)

Internal

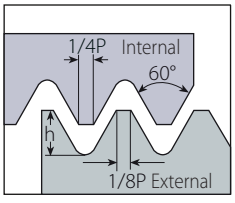

Defined by: R262 (DIN 13)
Tolerance class: 6g/6H

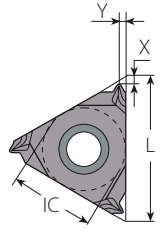

SCB
Sintered
Chipbreaker

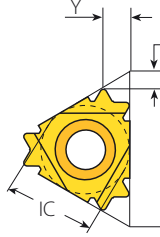

V6

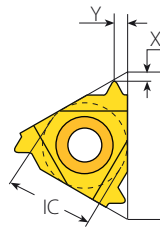



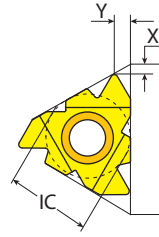

Standard



F-Line

Standard

Insert Size		Pitch	Ordering Code		Dimensions mm			Anvil		Toolholder	
IC	L mm	mm	RH	LH	h min	X	Y	RH	LH		
	3/8" SCB	16	1.0	3JIR1.0ISO...		0.58	0.7	0.8	Y13	-	AVR...-3
			1.25	3JIR1.25ISO...		0.72	0.7	0.8			
			1.5	3JIR1.5ISO...		0.87	0.7	0.8			
			1.75	3JIR1.75ISO...		1.01	1.1	1.5			
			2.0	3JIR2.0ISO...		1.15	1.1	1.5			
			2.5	3JIR2.5ISO...		1.44	1.1	1.5			
			3.0	3JIR3.0ISO...		1.73	1.1	1.5			
			3.5	3JIR3.5ISO...		2.02	1.2	1.5			
	3/8" V6	16	0.5	3IR0.5ISO-6C...		0.29	2.1	1.7	Y13-6C	-	AVR...-3 NVRC...-3 206/
			0.75	3IR0.75ISO-6C...		0.43	2.0	1.8			
			0.8	3IR0.8ISO-6C...		0.46	1.9	1.8			
			1.0	3IR1.0ISO-6C...		0.58	2.0	2.0			
			1.25	3IR1.25ISO-6C...		0.72	1.8	2.2			
			1.5	3IR1.5ISO-6C...		0.87	1.6	2.3			
			1.75	3IR1.75ISO-6C...		1.01	1.6	2.4			
			2.0	3IR2.0ISO-6C...		1.15	1.7	2.6			
	1/2"	22	3.5	4IR3.5ISO...	4IL3.5ISO...	2.02	1.6	2.3	Y14	YE4	AVR...-4 (LH)
			4.0	4IR4.0ISO...	4IL4.0ISO...	2.31	1.6	2.3			
			4.5	4IR4.5ISO...	4IL4.5ISO...	2.60	1.6	2.4			
			5.0	4IR5.0ISO...	4IL5.0ISO...	2.89	1.6	2.3			
			5.5	4IR5.5ISO...	4IL5.5ISO...	3.17	1.6	2.3			
			6.0	4IR6.0ISO...	4IL6.0ISO...	3.46	1.8	2.5			
	1/2" F	25	3.5	4FIR3.5ISO...		2.02	1.6	2.3	Y14F		AVRC...-4F
			4	4FIR4.0ISO...		2.31	1.6	2.3			
			4.5	4FIR4.5ISO...		2.60	1.6	2.4			
			5	4FIR5.0ISO...		2.89	1.6	2.3			
			5.5	4FIR5.5ISO...		3.18	1.6	2.3			
			6	4FIR6.0ISO...		3.46	1.8	2.5			
	5/8"	27	4.5	5IR4.5ISO...	5IL4.5ISO...	2.60	1.6	2.4	Y15	YE5	AVR...-5 (LH)
			5.0	5IR5.0ISO...	5IL5.0ISO...	2.89	1.6	2.3			
			5.5	5IR5.5ISO...	5IL5.5ISO...	3.17	1.6	2.3			
			6.0	5IR6.0ISO...	5IL6.0ISO...	3.46	1.8	2.5			

42

VARDEX

ISO Metric (con't)

Internal

Defined by: R262 (DIN 13)
Tolerance class: 6g/6H

U Style

V Style

M+ Style

F-Line M+

T+ Style

U Style



Insert Size		Pitch	Ordering Code		Dimensions mm			Anvil		Toolholder
IC	L mm	mm	RH+LH	h min	X	Y	RH	LH		
1/2"U	22	5.5	4UI5.5ISO...		3.17	2.4	11.0	YI4U	YE4U	AVR...-4U (LH)
		6.0	4UI6.0ISO...		3.46	2.1	11.0			
5/8"U	27	8.0	5UI8.0ISO...		4.62	2.4	13.7	YI5U	YE5U	AVR...-5U (LH)

V Style



Insert Size		Pitch	Ordering Code		Dimensions mm					Toolholder
IC	L mm	mm	RH	LH	h min	X	Y	T		
5/8"V	27	6.0	5VIR6.0ISO...	5VIL6.0ISO...	3.46	1.0	3.3	6	NVR...-5V (LH)	
		8.0	5VIR8.0ISO...	5VIL8.0ISO...	4.62	1.0	4.3	8		
		10.0	5VIR10.0ISO...	5VIL10.0ISO...	5.77	1.0	5.2	10		

M+ Style



F-LINE

Insert Size		Pitch	Teeth	Ordering Code		Dimensions mm			Anvil	
IC	L mm	mm		RH		h min	X	Y	RH	Toolholder
3/8"	16	1.0	3	3IR1.0ISO3M+...		0.58	1.7	2.6	YI3M	AVR...-3
		1.5	2	3IR1.5ISO2M+...		0.87	1.6	2.4		
		2.0	2	3IR2.0ISO2M+...		1.15	2.0	3.1		
1/2"	22	1.5	3	4IR1.5ISO3M+...		0.87	2.5	3.8	YI4M	AVR...-4
		2.0	2	4IR2.0ISO2M+...		1.15	2.0	3.1		
1/2"F	23	2.0	2	4FIR2.0ISO2M+...		1.15	2	3.1	YI4M2F	AVRC...-4MF
5/8"	27	3.0	2	5IR3.0ISO2M+...		1.73	3.0	4.7	YI5M	AVR...-5M

T+ Style



Insert Size		Pitch	Teeth	Ordering Code		Dimensions mm			Anvil	
IC	L mm	mm		RH		h min	X	Y	RH	Toolholder
1/2"	22	1.5	8	4IR1.5ISO8T+...		0.87	0.2	12.4	Y4T	AVR...-4T
		2.0	8	4IR2.0ISO8T+...		1.15	0.2	17.5		

ISO Metric (con't)

MEGALINE

Internal

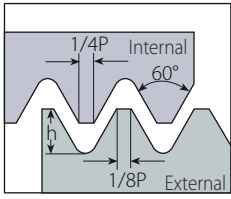

Defined by: R262 (DIN 13)
Tolerance class: 6g/6H

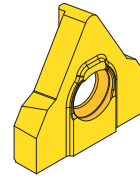

Mega Line

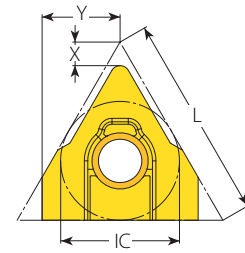

Internal



Insert Size		Pitch	Ordering Code	Dimensions mm			Number of Passes	
IC	L mm	mm	RH	h min	X	Y	0.07mm–Min. Depth of Cut (On radius)	0.15mm–Max. Depth of Cut (On radius)
5/8" MG	27	12.0	5MGIR12.0ISO...	6.94	2.65	10.4	99	46
		16.0	5MGIR16.0ISO...	9.32	3.01		132	62
		18.0	5MGIR18.0ISO...	10.49	3.15		149	69
		20.0	5MGIR20.0ISO...	11.63	3.29		165	77
		25.0	5MGIR25.0ISO...	14.57	3.65		206	96

Recommended thread infeed method for Mega Line: Flank or Modified Flank 1°.

Internal Toolholders for ISO Metric

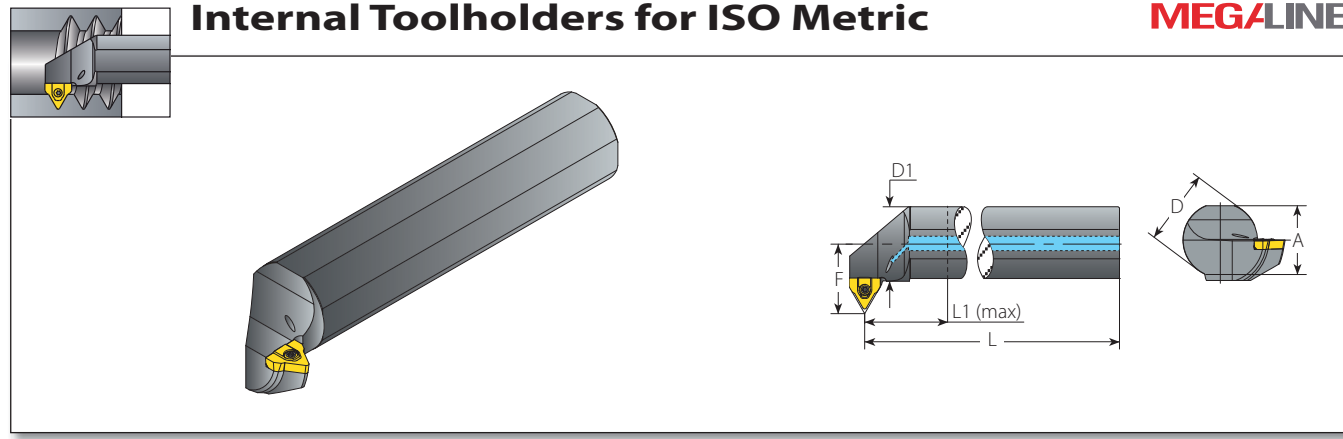

Internal											Spare Parts	
Insert	Ordering Code	Dimensions mm						Min. Bore Dia.	Thread Diameter Range (Min.-Max.)		Insert Screw	Torx Key
		RH	A	L	L1 (max)	D	D1		F	mm		
5MGIR12.0ISO...	NVRC40-5MG12ISO	36	232.5	100	40	39.7	41.5	60.0	(M73-90)x12	(M85-90)x12	S5MG	K6T
	NVRC50-5MG12ISO	46	257.5	125	50	49.7	46.5	70.0	(M83-90)x12	(M83-90)x12		
5MGIR16.0ISO...	NVRC40-5MG16ISO	36	232.5	100	40	39.7	41.5	59.7	(M77-190)x16	(M89-190)x16		
	NVRC50-5MG16ISO	46	257.5	125	50	49.7	46.5	69.7	(M87-190)x16	(M101-190)x16		
	NVRC60-5MG16ISO	57	282.5	150	60	59.7	51.5	79.7	(M97-190)x16	(M113-190)x16		
5MGIR18.0ISO...	NVRC40-5MG18ISO	36	232.5	100	40	39.7	41.5	65.5	(M85-230)x18	(M91-230)x18		
	NVRC50-5MG18ISO	46	257.5	125	50	49.7	46.5	69.5	(M89-230)x18	(M103-230)x18		
	NVRC60-5MG18ISO	57	282.5	150	60	59.7	51.5	79.5	(M99-230)x18	(M115-230)x18		
5MGIR20.0ISO...	NVRC40-5MG20ISO	36	232.5	100	40	39.7	41.5	70.4	(M92-290)x20	(M93-290)x20		
	NVRC50-5MG20ISO	46	257.5	125	50	49.7	46.5	70.4	(M92-290)x20	(M105-290)x20		
	NVRC60-5MG20ISO	57	282.5	150	60	59.7	51.5	79.4	(M101-290)x20	(M117-290)x20		
5MGIR25.0ISO...	NVRC40-5MG25ISO	36	232.5	100	40	39.7	41.5	82.0	(M109-405)x25	(M109-405)x25		
	NVRC50-5MG25ISO	46	257.5	125	50	49.7	46.5	82.0	(M109-405)x25	(M110-405)x25		
	NVRC60-5MG25ISO	57	282.5	150	60	59.7	51.5	82.0	(M109-405)x25	(M122-405)x25		

Recommended thread infeed method for Mega Line: Flank or Modified Flank 1°.

ISO Metric (con't)

Mini-V

Internal

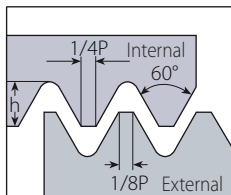

Defined by: R262 (DIN 13)
Tolerance class: 6g/6H

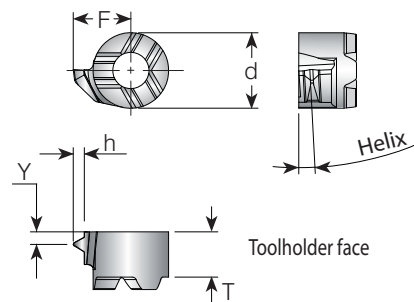

Mini-V



Min. Thread	Insert Style	Pitch	Ordering Code	Dimensions mm						Helix	Toolholder
				mm	RH	d	T	F	Y		
M8x0.5	V08	0.5	V08TH0.50ISOR...	6	3.8	3.86	0.35	0.29	1	.V08-...	
M8.5x0.75		0.75	V08TH0.75ISOR...			4.19	0.5	0.43	1.5		
M9x1.0		1.0	V08TH1.0ISOR...			4.29	0.5	0.58	2		
M10x1.25		1.25	V08TH1.25ISOR...			4.44	0.8	0.72	2.5		
M10x1.5		1.5	V08TH1.5ISOR...			4.58	0.9	0.87	3		
M12x1.75		1.75	V08TH1.75ISOR...			4.80	0.9	1.01	3		
M14x2.0	V11	2.0	V11TH2.0ISOR...	8	4.2	6.47	1.1	1.15	2.5	.V11-...	

ISO Metric (con't)

MINIPRO

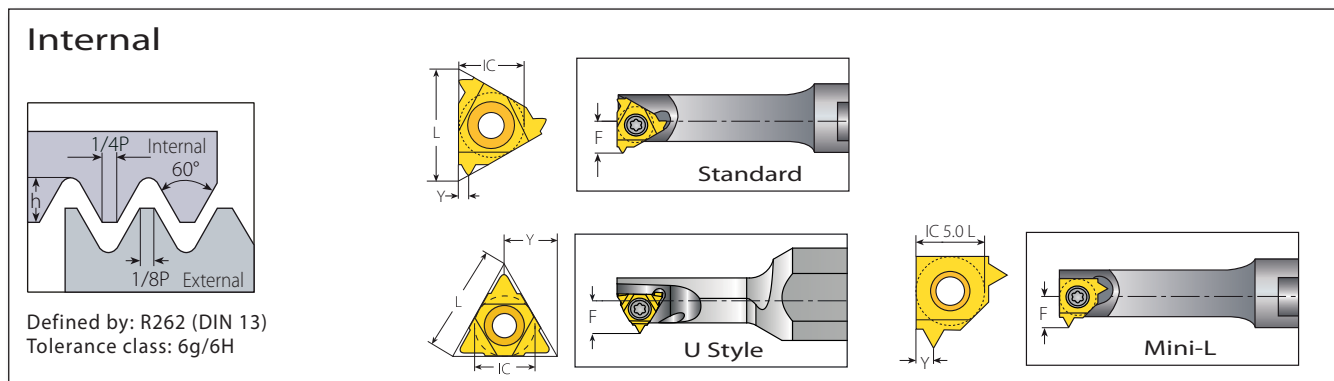

Mini-3 Standard

Insert Size		Pitch	Ordering Code		Dimensions mm			Min. Bore Dia.	Toolholder
IC mm	L mm	mm	RH	LH	h min	Y	F	mm	
4.0	6	0.25	4.0KIR0.25ISO...	4.0KIL0.25ISO...	0.15	0.25	3.3	5.95	.NVR.5-4.0K (LH)
		0.5	4.0KIR0.5ISO...	4.0KIL0.5ISO...	0.29	0.5	3.4	6.05	
		0.75	4.0KIR0.75ISO...	4.0KIL0.75ISO...	0.43	0.5	3.5	6.15	
		1.0	4.0KIR1.0ISO...	4.0KIL1.0ISO...	0.58	0.7	3.6	6.25	
		1.25	4.0KIR1.25ISO...	4.0KIL1.25ISO...	0.72	0.6	3.7	6.35	
5.0	8	0.5	5.0KIR0.5ISO...	5.0KIL0.5ISO...	0.29	0.5			.NVRC 7-5.0K (LH)
		0.75	5.0KIR0.75ISO...	5.0KIL0.75ISO...	0.43	0.5			
		1.0	5.0KIR1.0ISO...	5.0KIL1.0ISO...	0.58	0.6	4.7	7.8	
		1.25	5.0KIR1.25ISO...	5.0KIL1.25ISO...	0.72	0.7			
		1.5	5.0KIR1.5ISO...	5.0KIL1.5ISO...	0.87	0.7			
6.0	10	1.75	5.0KIR1.75ISO...	5.0KIL1.75ISO...	1.01	0.8			
		0.5	6.0IR0.5ISO...		0.29	0.6	4.4	9.3	.NVR1..-6.0
		0.75	6.0IR0.75ISO...		0.43	0.6	4.6	9.5	
		1.0	6.0IR1.0ISO...		0.58	0.7	4.7	9.6	
		1.25	6.0IR1.25ISO...		0.72	0.9	4.9	9.8	
		1.5	6.0IR1.5ISO...		0.87	1.0	5.0	9.9	
1.75	6.0IR1.75ISO...		1.01	1.05	5.2	10.0			
		2.0	6.0IR2.0ISO...		1.15	1.05	5.3	10.0	

Left handed tool supplied by request (Example: 6.0IL0.5ISO...).

Mini-3 U Style



Insert Size		Pitch	Ordering Code		Dimensions mm			Min. Bore Dia.	Toolholder
IC mm	L mm	mm	RH+LH	h min	Y	F	mm		
5.0U	8	2	5.0KUI2.0ISO...		1.23	4.0	5.7	9.0	.NVRC 8-5.0KU (LH)

Mini-L



Insert Size		Pitch	Ordering Code		Dimensions mm			Min. Bore Dia.	Toolholder
IC mm	mm	RH	LH	h min	Y	F	mm		
5.0L	0.35	5LIR0.35ISO...			0.20	0.3	3.75	7.3	.NVR10-5L
	0.5	5LIR0.5ISO...			0.29	0.4	3.75	7.3	
	0.75	5LIR0.75ISO...			0.43	0.6	3.91	7.5	
	1.0	5LIR1.0ISO...			0.58	0.7	4.06	7.7	
	1.25	5LIR1.25ISO...			0.72	0.9	4.21	7.8	
	1.5	5LIR1.5ISO...			0.87	1.0	4.35	7.9	
	1.75	5LIR1.75ISO...			1.01	1.05	4.51	8.0	
	2.0	5LIR2.0ISO...			1.15	1.05	4.65	8.0	

Left handed tool supplied by request (Example: 5LIL0.35ISO...).

ISO Metric (con't)

MINIPRO

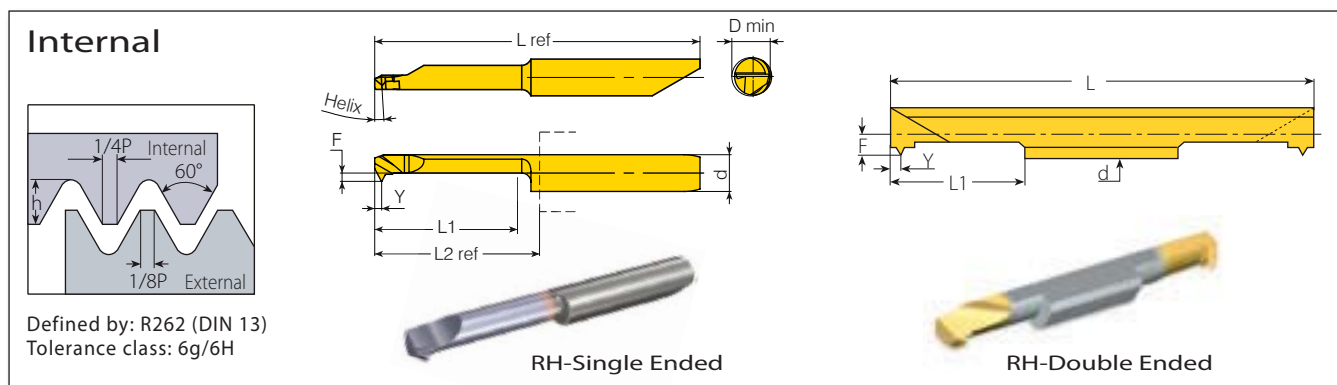

Defined by: R262 (DIN 13)
Tolerance class: 6g/6H

RH-Single Ended

RH-Double Ended

Micro - Double Ended

Thread	Insert Dia.	Pitch	Ordering Code	Dimensions mm					Min. Bore Dia.	Toolholder
	d mm	mm	RH	L1	L	F	Y	h min	mm	
M4 x 0.3	3.0	0.3	3.0SIR0.3ISO...	16	50	1.31	0.20	0.17	3.2	SMC...-3.0
M4 x 0.4		0.4	3.0SIR0.4ISO...	16	50	1.31	0.35	0.22	3.2	
M4 x 0.5		0.5	3.0SIR0.5ISO...	16	50	1.31	0.40	0.29	3.2	
M4 x 0.6		0.6	3.0SIR0.6ISO...	16	50	1.34	0.60	0.35	3.2	
M4.5 x 0.7		0.7	3.0SIR0.7ISO...	16	50	1.43	0.60	0.40	3.3	
M4.5 x 0.75		0.75	3.0SIR0.75ISO...	16	50	1.45	0.60	0.43	3.3	
M5 x 0.8	4.0	0.8	3.0SIR0.8ISO...	16	50	1.46	0.60	0.46	3.3	SMC...-4.0
M5 x 0.4		0.4	4.0SIR0.4ISO...	16	50	1.65	0.35	0.22	4.0	
M5 x 0.5		0.5	4.0SIR0.5ISO...	16	50	1.65	0.40	0.29	4.0	
M5 x 0.6		0.6	4.0SIR0.6ISO...	16	50	1.68	0.60	0.35	4.0	
M5 x 0.7		0.7	4.0SIR0.7ISO...	16	50	1.77	0.60	0.40	4.1	
M5.5 x 0.75		0.75	4.0SIR0.75ISO...	16	50	1.81	0.60	0.43	4.2	
M5.5 x 0.8	0.8	4.0SIR0.8ISO...	16	50	1.80	0.60	0.46	4.2	SMC...-6.0	
M6 x 1	1.0	4.0SIR1.0ISO...	16	50	1.96	0.90	0.58	4.3		
M6 x 0.5	0.5	6.0SIR0.5ISO...	16	50	1.90	0.60	0.29	5.4		
M6.5 x 0.75	0.75	6.0SIR0.75ISO...	16	50	2.06	0.60	0.43	5.6		
M7 x 1	1.0	6.0SIR1.0ISO...	16	50	2.21	0.70	0.58	5.7		
M8 x 1.25	1.25	6.0SIR1.25ISO...	16	50	2.36	0.90	0.72	5.9		
M10.5 x 1.5	1.5	6.0SIR1.5ISO...	16	50	2.50	1.00	0.87	6.0		

Left handed tool supplied by request (Example: 3.0SIL0.3ISO...).

Micro - Single Ended

microscope

Thread	Insert Dia.	Pitch	Ordering Code	Helix °	Dimensions mm						Min. Bore Dia.	Toolholder
	d mm	mm	RH/LH		L1	F	Y	h min	L2 ref*	L ref	D mm	
M4x0.5	4.0	0.5	MS429TH0.50ISOL16R/L...	3.5	16	0.9	0.4	0.29	18.4	35.4	3.4	MH...-4.0
M5x0.5		0.5	MS439TH0.50ISOL16R/L...			1.9	0.4	0.29			4.4	
M4x0.7		0.7	MS429TH0.70ISOL16R/L...			0.9	0.6	0.41			3.2	
M5x0.8		0.8	MS429TH0.80ISOL16R/L...			0.9	0.6	0.46			4.0	
M6x1.0		1.0	MS439TH1.00ISOL16R/L...			1.9	0.7	0.58			4.8	
M5.5x0.5		0.5	M542TH0.50ISOL16R/L...			1.7	0.4	0.29			4.9	
M5.5x0.75	0.75	M542TH0.75ISOL16R/L...	1.7	0.6	0.43	18.35	41.2	4.6	MH...-5.0			
M7x1.0	1.0	M549TH1.00ISOL16R/L...	2.4	0.7	0.58	5.8						
M6x0.5	0.5	M649TH0.50ISOL16R/L...	1.9	0.4	0.29	5.4						
M6.5x0.75	0.75	M649TH0.75ISOL16R/L...	1.9	0.6	0.43	5.6						
M7.5x1.0	1.0	M659TH1.00ISOL16R/L...	2.9	0.7	0.58	18.5	42.2	6.3	MH...-6.0			
M8x1.25	1.25	M659TH1.25ISOL16R/L...	2.9	0.9	0.72	6.3						
M10x1.5	1.5	M659TH1.50ISOL16R/L...	2.9	1.0	0.87	6.3						

* L2 Ref: Repeatability within +/-0.02.

American UN - UNC, UNF, UNEF, UNS

External

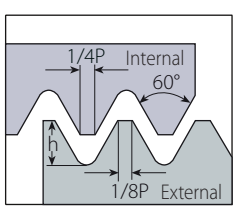

Defined by: ANSI B1.1:74
Tolerance class: 2A/2B

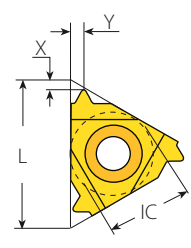

Standard

Standard

Insert Size		Pitch	Ordering Code		Dimensions mm			Anvil		Toolholder
IC	L mm	tpi	RH	LH	h min	X	Y	RH	LH	
1/4"	11	72	2ER72UN...	2EL72UN...	0.22	0.8	0.4	-	-	NL ..-2 (LH)
		64	2ER64UN...	2EL64UN...	0.24	0.8	0.4			
		56	2ER56UN...	2EL56UN...	0.28	0.7	0.4			
		48	2ER48UN...	2EL48UN...	0.32	0.6	0.6			
		44	2ER44UN...	2EL44UN...	0.35	0.6	0.6			
		40	2ER40UN...	2EL40UN...	0.39	0.6	0.6			
		36	2ER36UN...	2EL36UN...	0.43	0.6	0.6			
		32	2ER32UN...	2EL32UN...	0.49	0.6	0.6			
		28	2ER28UN...	2EL28UN...	0.56	0.6	0.7			
		27	2ER27UN...	2EL27UN...	0.58	0.7	0.8			
		24	2ER24UN...	2EL24UN...	0.65	0.7	0.8			
		20	2ER20UN...	2EL20UN...	0.78	0.8	0.9			
		18	2ER18UN...	2EL18UN...	0.87	0.8	1.0			
		16	2ER16UN...	2EL16UN...	0.97	0.9	1.1			
3/8"	16	80	3ER80UN...	3EL80UN...	0.18	0.8	0.3	YE3	YI3	AL..-3 (LH)
		72	3ER72UN...	3EL72UN...	0.22	0.8	0.4			
		64	3ER64UN...	3EL64UN...	0.24	0.8	0.4			
		56	3ER56UN...	3EL56UN...	0.28	0.7	0.4			
		48	3ER48UN...	3EL48UN...	0.32	0.6	0.6			
		44	3ER44UN...	3EL44UN...	0.35	0.6	0.6			
		40	3ER40UN...	3EL40UN...	0.39	0.6	0.6			
		36	3ER36UN...	3EL36UN...	0.43	0.6	0.6			
		32	3ER32UN...	3EL32UN...	0.49	0.6	0.6			
		28	3ER28UN...	3EL28UN...	0.56	0.6	0.7			
		27	3ER27UN...	3EL27UN...	0.58	0.7	0.8			
		26	3ER26UN...	3EL26UN...	0.59	0.7	0.8			
		24	3ER24UN...	3EL24UN...	0.65	0.7	0.8			
		20	3ER20UN...	3EL20UN...	0.78	0.8	0.9			
		18	3ER18UN...	3EL18UN...	0.87	0.8	1.0			
		16	3ER16UN...	3EL16UN...	0.97	0.9	1.1			
		14	3ER14UN...	3EL14UN...	1.11	1.0	1.2			
		13	3ER13UN...	3EL13UN...	1.20	1.0	1.3			
12	3ER12UN...	3EL12UN...	1.30	1.1	1.4					
11.5	3ER11.5UN...	3EL11.5UN...	1.35	1.1	1.5					
11	3ER11UN...	3EL11UN...	1.42	1.1	1.5					
10	3ER10UN...	3EL10UN...	1.56	1.1	1.5					
9	3ER9UN...	3EL9UN...	1.73	1.2	1.7					
8	3ER8UN...	3EL8UN...	1.95	1.2	1.6					



American UN - UNC, UNF, UNEF, UNS (con't)

External

Defined by: ANSI B1.1:74
Tolerance class: 2A/2B

SCB Sintered Chipbreaker V6 Standard F-Line U Style

Standard

Insert Size		Pitch	Ordering Code		Dimensions mm			Anvil		Toolholder	
IC	L mm	tpi	RH	LH	h min	X	Y	RH	LH		
	3/8"	16	36	3JER36UN...		0.43	1.2	0.5	YE3	-	AL..-3
			32	3JER32UN...		0.49	1.2	0.5			
			28	3JER28UN...		0.56	0.7	0.8			
			24	3JER24UN...		0.65	0.7	0.8			
			20	3JER20UN...		0.78	0.7	0.8			
			18	3JER18UN...		0.87	0.7	0.8			
			16	3JER16UN...		0.97	0.8	0.8			
			14	3JER14UN...		1.11	1.2	1.5			
			13	3JER13UN...		1.20	1.2	1.5			
			12	3JER12UN...		1.30	1.3	1.5			
			10	3JER10UN...		1.56	1.2	1.5			
9	3JER9UN...		1.73	1.2	1.5						
8	3JER8UN...		1.95	1.3	1.5						
	3/8"	16	32	3ER32UN-6C...		0.49	2.0	1.9	YE3-6C	-	AL..-3
			28	3ER28UN-6C...		0.56	2.0	2.0			
			24	3ER24UN-6C...		0.65	1.9	2.0			
			20	3ER20UN-6C...		0.78	1.8	2.1			
			18	3ER18UN-6C...		0.87	1.9	2.3			
			16	3ER16UN-6C...		0.97	1.8	2.4			
			14	3ER14UN-6C...		1.11	1.8	2.7			
	1/2"	22	7	4ER7UN...	4EL7UN...	2.22	1.6	2.3	YE4	YI4	AL..-4 (LH)
			6	4ER6UN...	4EL6UN...	2.60	1.6	2.3			
			5	4ER5UN...	4EL5UN...	3.12	1.7	2.5			
	1/2"	23	7	4FER7UN...		2.22	1.6	2.3	YE4F		AL..-4F
			6	4FER6UN...		2.60	1.6	2.3			
			5	4FER5UN...		3.12	1.7	2.5			
	5/8"	27	4.5	5ER4.5UN...	5EL4.5UN...	3.46	1.9	2.7	YE5	YI5	AL..-5 (LH)
			4	5ER4UN...	5EL4UN...	3.89	2.1	3.0			

U Style

Insert Size		Pitch	Ordering Code		Dimensions mm			Anvil		Toolholder
IC	L mm	tpi	RH+LH		h min	X	Y	RH	LH	
	1/2"U	22	4.5	4UE4.5UN...	3.46	2.0	11.0	YE4U	YI4U	AL..-4U (LH)
			4	4UE4UN...	3.89	2.0	11.0			
5/8"U	27	3	5UE3UN...		5.19	2.5	13.7	YE5U	YI5U	AL..-5U (LH)

American UN - UNC, UNF, UNEF, UNS (con't)

External



Defined by: ANSI B1.1:74
Tolerance class: 2A/2B



V Style / Slim Throat

Slim Throat

Insert Size		Pitch	Ordering Code		Dimensions mm				Toolholder
IC	L mm	tpi	RH	LH	h min	X	Y	T	
1/4"V	11	20	2VER20UN...	2VEL20UN...	0.78	0.69	2.3	3.2	NL..-2V (LH)
		18	2VER18UN...	2VEL18UN...	0.87	0.69	2.2	3.2	
		16	2VER16UN...	2VEL16UN...	0.97	0.69	2.2	3.2	
		14	2VER14UN...	2VEL14UN...	1.11	0.69	2.0	3.2	
		12	2VER12UN...	2VEL12UN...	1.30	0.69	1.8	3.2	
3/8"V	16	32	3VER32UN...	3VEL32UN...	0.48	1.1	3.0	3.6	NL..-3V (LH)
		28	3VER28UN...	3VEL28UN...	0.56	1.1	3.0	3.6	
		24	3VER24UN...	3VEL24UN...	0.65	1.1	2.9	3.6	
		20	3VER20UN...	3VEL20UN...	0.78	1.1	2.7	3.6	
		18	3VER18UN...	3VEL18UN...	0.87	1.1	2.6	3.6	
		16	3VER16UN...	3VEL16UN...	0.97	1.1	2.55	3.6	
		14	3VER14UN...	3VEL14UN...	1.11	1.1	2.4	3.6	
		12	3VER12UN...	3VEL12UN...	1.30	1.1	2.2	3.6	
		10	3VER10UN...	3VEL10UN...	1.56	1.1	2.1	3.6	
1/2"V	22	7	4VER7UN...	4VEL7UN...	2.22	1.1	2.5	4.8	NL..-4V (LH)



V Style

Insert Size		Pitch	Ordering Code		Dimensions mm				Toolholder
IC	L mm	tpi	RH	LH	h min	X	Y	T	
5/8"V	27	4	5VER4UN...	5VEL4UN...	3.89	1.0	3.3	6	NL..-5V-6 (LH)
		3	5VER3UN...	5VEL3UN...	5.19	1.0	4.3	8	NL..-5V-8 (LH)



American UN - UNC, UNF, UNEF, UNS (con't)

External

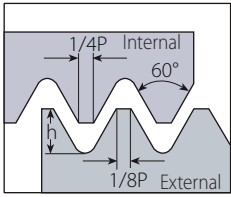

Defined by: ANSI B1.1:74
Tolerance class: 2A/2B

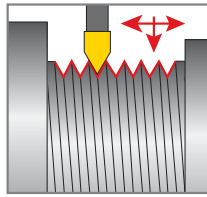

RS/LS Varied range of threading standards for machining between shoulders and close to spindle.

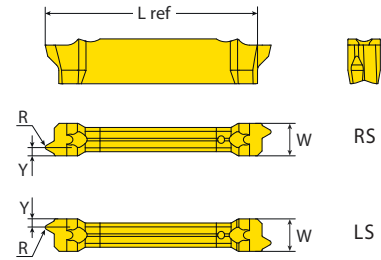

VG-Cut



Pocket Size	Ordering Code	Dimensions mm					No. of Passes	Helix	Min. Thread Diameter	Toolholder
		RH	W ref	Pitch tpi	h min	Y				
3	VGD3.0UN32RH-RS/LS...		32	0.49	0.66		5 - 8		5/32"-32 UNC	VGE...T12
	VGD3.0UN28RH-RS/LS...		28	0.56	0.71		5 - 9		3/16"-28 UNC	
	VGD3.0UN24RH-RS/LS...		24	0.65	0.77		5 - 9		7/32"-24 UNC	
	VGD3.0UN20RH-RS/LS...	3.00	20	0.78	0.86	21.9	6 - 10	2.5°	1/4"-20 UNC	
	VGD3.0UN18RH-RS/LS...		18	0.87	0.93		7 - 12		5/16"-18 UNC	
	VGD3.0UN16RH-RS/LS...		16	0.97	1.10		7 - 12		3/8"-16 UNC	
	VGD3.0UN14RH-RS/LS...		14	1.11	1.09		8 - 14		7/16"-14 UNC	
	VGD3.0UN12RH-RS/LS...		12	1.30	1.30		8 - 14		9/16"-14 UNC	

LH Helix threads available upon request.

American UN - UNC, UNF, UNEF, UNS (con't)

External

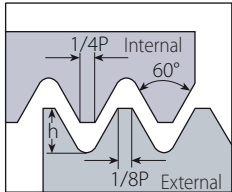

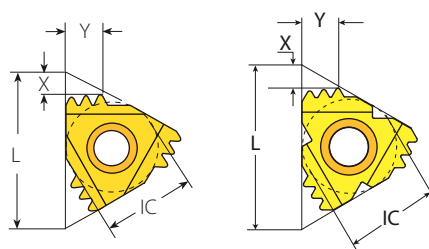

Defined by: ANSI B1.1:74
Tolerance class: 2A/2B



M+ Style
F-Line M+

M+ Style



	Insert Size		Teeth	Ordering Code	Dimensions mm			Anvil		
	IC	L mm			h min	X	Y	RH	Toolholder	
	3/8"	16	20	3	3ER20UN3M+...	0.78	2.2	3.3	YE3M	AL...-3
			18	2	3ER18UN2M+...	0.87	1.5	2.2		
			18	3	3ER18UN3M+...	0.87	2.3	3.6		
			16	2	3ER16UN2M+...	0.97	1.7	2.5		
			14	2	3ER14UN2M+...	1.11	1.9	2.8		
			12	2	3ER12UN2M+...	1.3	2.2	3.3		
	1/2"	22	16	3	4ER16UN3M+...	0.97	2.6	4.1	YE4M	AL...-4
			14	2	4ER14UN2M+...	1.11	1.9	2.8		
			12	2	4ER12UN2M+...	1.3	2.2	3.3		
			12	3	4ER12UN3M+...	1.3	3.4	5.4		
			11	2	4ER11UN2M+...	1.42	2.3	3.6		
			10	2	4ER10UN2M+...	1.56	2.5	3.9		
	1/2"	23	16	3	4FER16UN3M+...	0.97	2.6	4.1	YE4M3F	AL...-4MF
			12	3	4FER12UN3M+...	1.3	3.4	5.4		
			12	2	4FER12UN2M+...	1.3	2.2	3.3	YE4M2F	
			10	2	4FER10UN2M+...	1.56	2.5	3.9		
	5/8"	27	8	2	5ER8UN2M+...	1.95	3.1	4.9	YE5M	AL...-5M

F LINE

American UN - UNC, UNF, UNEF, UNS (con't)

Internal

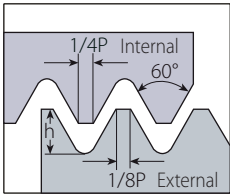

Defined by: ANSI B1.1:74
Tolerance class: 2A/2B

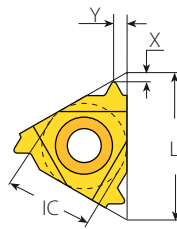

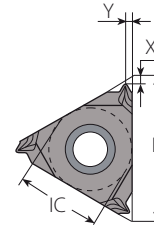

Standard



SCB
Sintered
Chipbreaker

Standard

Insert Size		Pitch	Ordering Code		Dimensions mm			Anvil		Toolholder	
IC	L mm	tpi	RH	LH	h min	X	Y	RH	LH		
	1/4"	11	72	2IR72UN...	2IL72UN...	0.20	0.8	0.3	-	-	NVR..-2 (LH)
			64	2IR64UN...	2IL64UN...	0.23	0.8	0.4			
			56	2IR56UN...	2IL56UN...	0.26	0.7	0.4			
			48	2IR48UN...	2IL48UN...	0.31	0.6	0.6			
			44	2IR44UN...	2IL44UN...	0.33	0.6	0.6			
			40	2IR40UN...	2IL40UN...	0.37	0.6	0.6			
			36	2IR36UN...	2IL36UN...	0.41	0.6	0.6			
			32	2IR32UN...	2IL32UN...	0.46	0.6	0.6			
			28	2IR28UN...	2IL28UN...	0.52	0.6	0.7			
			27	2IR27UN...	2IL27UN...	0.54	0.7	0.8			
			24	2IR24UN...	2IL24UN...	0.61	0.7	0.8			
			20	2IR20UN...	2IL20UN...	0.73	0.8	0.9			
			18	2IR18UN...	2IL18UN...	0.81	0.8	1.0			
			16	2IR16UN...	2IL16UN...	0.92	0.9	1.1			
14	2IR14UN...	2IL14UN...	1.05	0.9	1.1						
12	2IR12UN...	2IL12UN...	1.22	0.8	1.1						
11	2IR11UN...	2IL11UN...	1.33	0.8	1.1						
	1/4" SCB	11	36	2JIR36UN...		0.41	1.1	0.5	-	-	NVR..-2
			32	2JIR32UN...		0.46	1.2	0.5			
			28	2JIR28UN...		0.52	0.6	0.8			
			24	2JIR24UN...		0.61	0.7	0.8			
			20	2JIR20UN...		0.73	0.6	0.8			
			18	2JIR18UN...		0.81	0.6	0.8			
16	2JIR16UN...		0.97	0.7	0.8						
	3/8"	16	72	3IR72UN...	3IL72UN...	0.20	0.8	0.3	Y13	YE3	AVR..-3 (LH)
			64	3IR64UN...	3IL64UN...	0.23	0.8	0.4			
			56	3IR56UN...	3IL56UN...	0.26	0.7	0.4			
			48	3IR48UN...	3IL48UN...	0.31	0.6	0.6			
			44	3IR44UN...	3IL44UN...	0.33	0.6	0.6			
			40	3IR40UN...	3IL40UN...	0.37	0.6	0.6			
			36	3IR36UN...	3IL36UN...	0.41	0.6	0.6			
			32	3IR32UN...	3IL32UN...	0.51	0.6	0.6			
			28	3IR28UN...	3IL28UN...	0.52	0.6	0.7			
			27	3IR27UN...	3IL27UN...	0.54	0.7	0.8			
			26	3IR26UN...	3IL26UN...	0.56	0.7	0.75			

American UN - UNC, UNF, UNEF, UNS (con't)

Internal

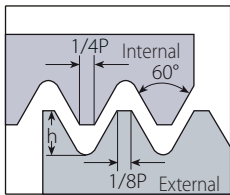

Defined by: ANSI B1.1:74
Tolerance class: 2A/2B

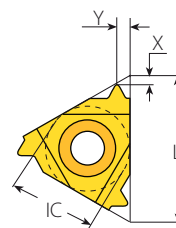

Standard

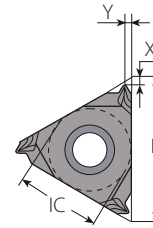

SCB
Sintered
Chipbreaker

Standard



Insert Size		Pitch	Ordering Code		Dimensions mm			Anvil		Toolholder
IC	L mm	tpi	RH	LH	h min	X	Y	RH	LH	
3/8"	16	24	3IR24UN...	3IL24UN...	0.61	0.7	0.8	Y13	YE3	AVR..-3 (LH)
		20	3IR20UN...	3IL20UN...	0.73	0.8	0.9			
		18	3IR18UN...	3IL18UN...	0.81	0.8	1.0			
		16	3IR16UN...	3IL16UN...	0.92	0.9	1.1			
		14	3IR14UN...	3IL14UN...	1.05	0.9	1.2			
		13	3IR13UN...	3IL13UN...	1.13	1.0	1.3			
		12	3IR12UN...	3IL12UN...	1.22	1.1	1.4			
		11.5	3IR11.5UN...	3IL11.5UN...	1.28	1.1	1.5			
		11	3IR11UN...	3IL11UN...	1.33	1.1	1.5			
		10	3IR10UN...	3IL10UN...	1.47	1.1	1.5			
3/8" SCB	16	8	3IR8UN...	3IL8UN...	1.83	1.1	1.5	Y13	-	AVR..-3
		9	3IR9UN...	3IL9UN...	1.63	1.2	1.7			
		10	3IR10UN...	3IL10UN...	1.47	1.1	1.5			
		12	3IR12UN...	3IL12UN...	1.22	1.1	1.5			
		13	3IR13UN...	3IL13UN...	1.13	1.1	1.5			
		14	3IR14UN...	3IL14UN...	1.05	1.1	1.5			
		16	3IR16UN...	3IL16UN...	0.92	0.7	0.8			
		18	3IR18UN...	3IL18UN...	0.81	0.6	0.8			
		20	3IR20UN...	3IL20UN...	0.73	0.6	0.8			
		28	3IR28UN...	3IL28UN...	0.52	0.6	0.8			

American UN - UNC, UNF, UNEF, UNS (con't)

Internal

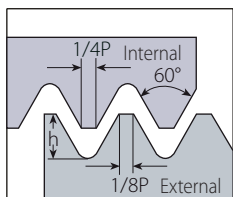

Defined by: ANSI B1.1:74
Tolerance class: 2A/2B

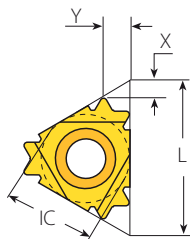

V6

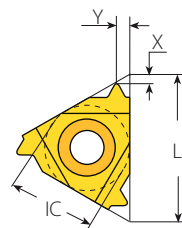

Standard

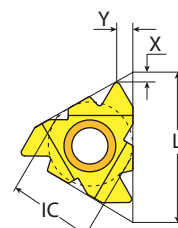

F-Line

Standard



Insert Size		Pitch	Ordering Code		Dimensions mm			Anvil		Toolholder
IC	L mm	tpi	RH	LH	h min	X	Y	RH	LH	
3/8" V6	16	32	3IR32UN-6C...		0.51	2.0	1.8	Y13-6C	-	AVR..-3 NVRC..-3 206/..
		28	3IR28UN-6C...		0.52	1.9	1.9			
		24	3IR24UN-6C...		0.61	1.9	1.9			
		20	3IR20UN-6C...		0.73	1.8	2.1			
		18	3IR18UN-6C...		0.81	1.7	2.1			
		16	3IR16UN-6C...		0.92	1.6	2.2			
		14	3IR14UN-6C...		1.05	1.7	2.5			
		13	3IR13UN-6C...		1.13	1.8	2.7			
1/2"	22	7	4IR7UN...	4IL7UN...	2.09	1.6	2.3	Y14	YE4	AVR..-4 (LH)
		6	4IR6UN...	4IL6UN...	2.44	1.6	2.3			
		5	4IR5UN...	4IL5UN...	2.93	1.6	2.3			
1/2"F	23	7	4FIR7UN...		2.09	1.6	2.3	Y14F		AVRC...-4F
		6	4FIR6UN...		2.44	1.6	2.3			
		5	4FIR5UN...		2.93	1.6	2.3			
5/8"	27	4.5	5IR4.5UN...	5IL4.5UN...	3.26	1.7	2.4	Y15	YE5	AVR..-5 (LH)
		4	5IR4UN...	5IL4UN...	3.67	1.8	2.7			

American UNC (con't)

Internal

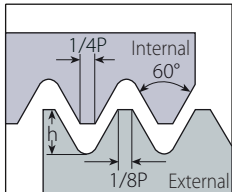

Defined by: ANSI B1.1:74
Tolerance class: 2A/2B

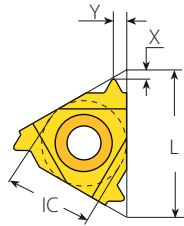

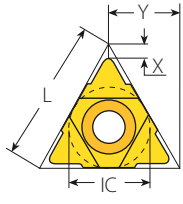

Coarse Pitch





U Style Coarse Pitch

Coarse Pitch RH

	Thread	Insert Size		Ordering Code	Dimensions mm			Toolholder RH	Min Bore Dia.
		IC	L mm	RH	h min	X	Y	mm	
	1/2" x 13UN	6.0	10	6.0IR13UN...158/001	1.13	0.8	0.9	BNVR10S-6.0	10.6
	9/16" x 12UN	1/4"	11	2IR12UN...158/002	1.22	0.9	1.0	NVRC10-2-156/001	12.0
	5/8" x 11UN	1/4"U		2UIR11UN...158/003	1.33	1.2	5.5	NVRC11-2U-156/002	13.4
	3/4" x 10UN			3IR10UN...	1.47	1.1	1.5	NVRC13-3-156/016	16.3
	7/8" x 9UN	3/8"	16	3IR9UN...	1.63	1.2	1.7	NVRC13-3-156/016	19.2
	1" x 8UN			3IR8UN...	1.83	1.1	1.5	NVRC16-3	22.0
	1 1/8" x 7UN		22	4IR7UN...	2.09	1.6	2.3	NVRC20-4	24.6
	1 1/4" x 7UN	1/2"		4IR7UN...	2.09	1.6	2.3	NVRC20-4	27.8
	1 3/8" x 6UN			4IR6UN...	2.44	1.6	2.3	NVRC20-4	30.3

Coarse Pitch LH

	Thread	Insert Size		Ordering Code	Dimensions mm			Toolholder LH	Min Bore Dia.
		IC	L mm	LH	h min	X	Y	mm	
	1/2" x 13UN	6.0	10	6.0IL13UN...158/016	1.13	0.8	0.9	BNVR10S-6.0LH	10.6
	9/16" x 12UN	1/4"	11	2IL12UN...158/017	1.22	0.9	1.0	NVRC10-2LH-156/036	12.0
	5/8" x 11UN	1/4"U		2UIR11UN...158/003	1.33	1.2	5.5	NVRC11-2ULH-156/035	13.4
	3/4" x 10UN			3IL10UN...	1.47	1.1	1.5	NVRC13-3LH-156/026	16.3
	7/8" x 9UN	3/8"	16	3IL9UN...	1.63	1.2	1.7	NVRC13-3LH-156/026	19.2
	1" x 8UN			3IL8UN...	1.83	1.1	1.5	NVRC16-3LH	22.0
	1 1/8" x 7UN		22	4IL7UN...	2.09	1.6	2.3	NVRC20-4LH	24.6
	1 1/4" x 7UN	1/2"		4IL7UN...	2.09	1.6	2.3	NVRC20-4LH	27.8
	1 3/8" x 6UN			4IL6UN...	2.44	1.6	2.3	NVRC20-4LH	30.3

U Type RH inserts can be used for both LH and RH applications.

American UN - UNC, UNF, UNEF, UNS (con't)

Internal

Defined by: ANSI B1.1:74
Tolerance class: 2A/2B

U Style **V Style** **M+ Style** **F-Line M+**

U Style



Insert Size		Pitch	Ordering Code		Dimensions mm			Anvil		Toolholder
IC	L mm	tpi	RH+LH	h min	X	Y	RH	LH		
1/2"U	22	4.5	4UI4.5UN...	3.26	2.4	11.0	Y14U	YE4U	AVR..-4U (LH)	
		4	4UI4UN...	3.67	2.4	11.0				
5/8"U	27	3	5UI3UN...	4.89	2.7	13.7	Y15U	YE5U	AVR..-5U (LH)	

V Style



Insert Size		Pitch	Ordering Code		Dimensions mm					Toolholder
IC	L mm	tpi	RH	LH	h min	X	Y	T		
5/8"V	27	4	5VIR4UN...	5VIL4UN...	3.67	1.0	3.3	6	NVR..-5V (LH)	
		3	5VIR3UN...	5VIL3UN...	4.89	1.0	4.3	8		

M+ Style



F-LINE

Insert Size		Pitch	Teeth	Ordering Code		Dimensions mm			Anvil	
IC	L mm	tpi		RH		h min	X	Y	RH	Toolholder
3/8"	16	12	2	3IR12UN2M+...		1.22	2.2	3.3	Y13M	AVR..-3
		14	2	3IR14UN2M+...		1.05	1.9	2.8		
		16	2	3IR16UN2M+...		0.92	1.7	2.5		
1/2"	22	16	3	4IR16UN3M+...		0.92	2.6	4.1	Y14M	AVR..-4
		14	2	4IR14UN2M+...		1.05	1.9	2.8		
		12	2	4IR12UN2M+...		1.22	2.2	3.3		
1/2"F	23	12	2	4FIR12UN2M+...		1.22	2.2	3.3	Y14M2F	AVRC...-4MF
5/8"	27	8	2	5IR8UN2M+...		1.83	3.1	4.9	Y15M	AVR..-5M

American UN - UNC, UNF, UNEF, UNS (con't)

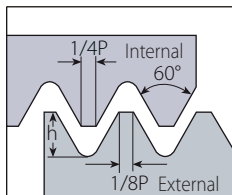
Mini-V
Internal

Defined by: ANSI B1.1:74
Tolerance class: 2A/2B

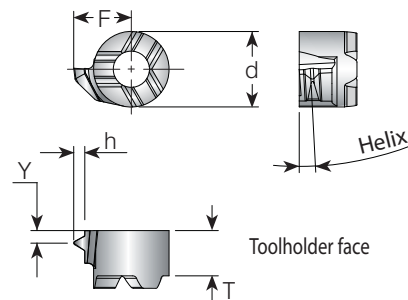
Mini-V

Min. Thread	Insert Style	Pitch	Ordering Code	Dimensions mm				Helix	Toolholder	
				tpi	RH	d	T			F
3/8"-32UNEF	V08	32	V08TH32UNR...	6	3.8	4.21	0.5	0.46	1.5	.V08-...
3/8"-28UN		28	V08TH28UNR...			4.28	0.5	0.52	2	
3/8"-24UNF		24	V08TH24UNR...			4.32	0.65	0.61	2	
3/8"-20UN		20	V08TH20UNR...			4.45	0.8	0.73	2.5	
3/8"-18UNS		18	V08TH18UNR...			4.53	0.85	0.81	2.5	
3/8"-16UNC		16	V08TH16UNR...			4.33	0.95	0.92	2.5	
7/16"-14UNC	V11	14	V08TH14UNR...	8	4.2	4.78	1.1	1.05	3	.V11-...
9/16"-12UNC		12	V11TH12UNR...			6.44	1.24	1.22	2.5	

American UN - UNC, UNF, UNEF, UNS (con't)

MINIPRO

Internal

Defined by: ANSI B1.1:74
Tolerance class: 2A/2B

Standard

U Style

Mini-3 Standard

Insert Size		Pitch	Ordering Code		Dimensions mm			Min. Bore Dia.	Toolholder
IC mm	L mm	tpi	RH	LH	h min	Y	F	mm	
4.0	6	32	4.0KIR32UN...	4.0KIL32UN...	0.46	0.5	3.50	6.15	.NVR.5-4.0K (LH)
		28	4.0KIR28UN...	4.0KIL28UN...	0.52	0.6	3.50	6.15	
		24	4.0KIR24UN...	4.0KIL24UN...	0.61	0.6	3.60	6.25	
		20	4.0KIR20UN...	4.0KIL20UN...	0.73	0.6	3.70	6.35	
		18	4.0KIR18UN...	4.0KIL18UN...	0.81	0.7	3.70	6.35	
5.0	8	32	5.0KIR32UN...	5.0KIL32UN...	0.46	0.5	4.7	7.8	.NVRC 7-5.0K (LH)
		28	5.0KIR28UN...	5.0KIL28UN...	0.52	0.6			
		24	5.0KIR24UN...	5.0KIL24UN...	0.61	0.6			
		20	5.0KIR20UN...	5.0KIL20UN...	0.73	0.7			
		18	5.0KIR18UN...	5.0KIL18UN...	0.81	0.7			
		16	5.0KIR16UN...	5.0KIL16UN...	0.92	0.7			
6.0	10	40	6.0IR40UN...		0.37	0.6	4.50	9.5	.NVR1..-6.0
		32	6.0IR32UN...		0.46	0.6	4.60	9.5	
		28	6.0IR28UN...		0.52	0.65	4.70	9.6	
		24	6.0IR24UN...		0.61	0.75	4.80	9.7	
		20	6.0IR20UN...		0.73	0.9	4.90	9.8	
		18	6.0IR18UN...		0.81	1.0	5.00	9.9	
		16	6.0IR16UN...		0.92	1.05	5.10	10.0	
14	6.0IR14UN...		1.05	1.05	5.20	10.0			

Left handed tool supplied by request (Example: 6.0IL40UN...).

Mini-3 U Style

Insert Size		Pitch	Ordering Code		Dimensions mm			Min. Bore Dia.	Toolholder
IC mm	L mm	tpi	RH+LH		h min	Y	F	mm	
5.0U	8	13	5.0KUI13UN...		1.2	4.0	5.6	9.0	.NVRC 8-5.0KU (LH)
		12	5.0KUI12UN...		1.3		5.7		
		11	5.0KUI11UN...		1.42		5.7		

American UN - UNC, UNF, UNEF, UNS (con't)

MINIPRO

Internal

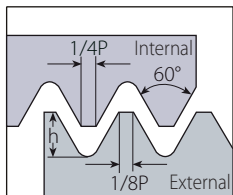

Defined by: ANSI B1.1:74
Tolerance class: 2A/2B

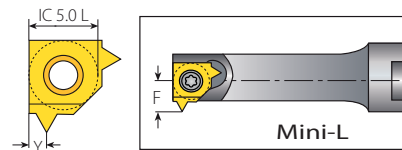

Mini-L



Insert Size	Pitch	Ordering Code		Dimensions mm			Min. Bore Dia.	Toolholder
		RH	LH	h min	Y	F	mm	
5.0L	40	5LIR40UN...		0.37	0.6	3.80	7.6	.NVR10.-5L
	32	5LIR32UN...		0.46	0.6	3.92	7.6	
	28	5LIR28UN...		0.52	0.65	3.99	7.6	
	24	5LIR24UN...		0.61	0.75	4.09	7.6	
	20	5LIR20UN...		0.73	0.9	4.21	7.7	
	18	5LIR18UN...		0.81	1.0	4.30	7.8	
	16	5LIR16UN...		0.92	1.05	4.41	7.8	
	14	5LIR14UN...		1.05	1.05	4.54	7.9	

Left handed tool supplied by request (Example: 5LIL40UN...).

American UN - UNC, UNF, UNEF, UNS (con't)

MINIPRO

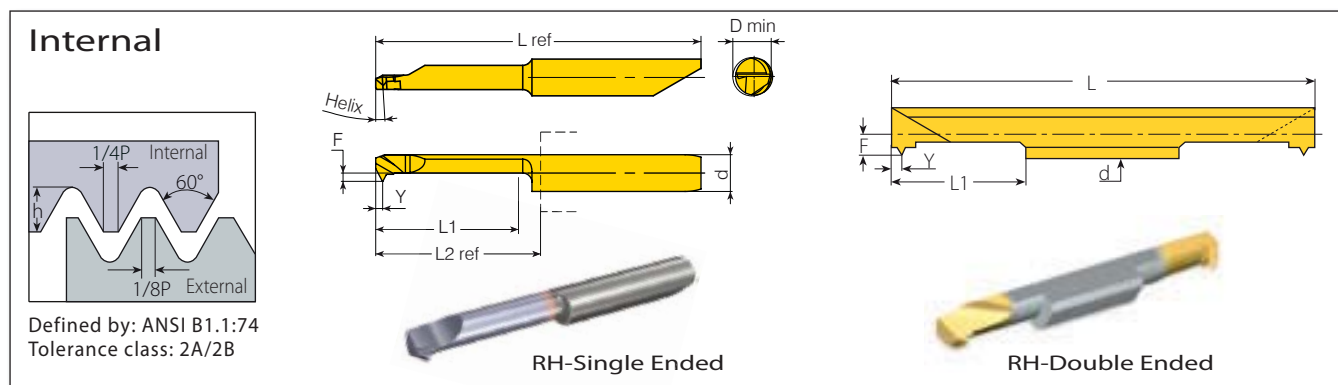

Micro - Double Ended

Thread	Insert Dia. d mm	Pitch mm	Ordering Code RH	Dimensions mm					Min. Bore Dia. mm	Toolholder
				L1	L	F	Y	h min		
10-40UNS	3.0	40	3.0SIR40UN...	16	50	1.35	0.60	0.37	3.2	SMC...-3.0
8-36UNF		36	3.0SIR36UN...	16	50	1.46	0.60	0.41	3.2	
8-32UNF		32	3.0SIR32UN...	16	50	1.40	0.60	0.46	3.3	
10-40UNS	4.0	40	4.0SIR40UN...	16	50	1.65	0.60	0.37	4.0	SMC...-4.0
10-36UNS		36	4.0SIR36UN...	16	50	1.70	0.60	0.41	4.1	
12-32UNEF		32	4.0SIR32UN...	16	50	1.76	0.60	0.46	4.1	
12-28UNF	4.0	28	4.0SIR28UN...	16	50	1.83	0.65	0.52	4.2	SMC...-4.0
1/4"-27UNS		27	4.0SIR27UN...	16	50	1.85	0.75	0.54	4.2	
12-24UNC		24	4.0SIR24UN...	16	50	1.93	0.75	0.61	4.3	
1/4"-20UNC	6.0	20	4.0SIR20UN...	16	50	2.03	0.76	0.73	4.3	SMC...-6.0
1/4"-32UNEF		32	6.0SIR32UN...	16	50	2.01	0.60	0.46	5.5	
5/16"-28UN		28	6.0SIR28UN...	16	50	2.08	0.65	0.52	5.6	
5/16"-27UNS	6.0	27	6.0SIR27UN...	16	50	2.10	0.75	0.54	5.6	SMC...-6.0
5/16"-24UNF		24	6.0SIR24UN...	16	50	2.18	0.75	0.61	5.7	
5/16"-20UN		20	6.0SIR20UN...	16	50	2.30	0.90	0.73	5.8	
5/16"-18UNC	6.0	18	6.0SIR18UN...	16	50	2.39	1.00	0.81	5.9	SMC...-6.0
3/8"-16UNC		16	6.0SIR16UN...	16	50	2.50	1.05	0.92	6.0	

Left handed tool supplied by request (Example: 6.0SIL16UN...).

Micro - Single Ended

microscope

Thread	Insert Dia. d mm	Pitch tpi	Ordering Code RH/LH	Helix °	Dimensions mm							Min. Bore Dia. D mm	Toolholder
					L1	F	Y	h min	L2 ref*	L ref			
No.8-32UNC	4.0	32	MS429TH32UNL16R/L...	3.5	16	0.92	0.6	0.46	18.4	35.4	3.3	MH...-4.0	
No.10-28UNS		28	MS429TH28UNL16R/L...			0.92	0.65	0.52			3.6		
1/4"-27UNS	5.0	27	M549TH27UNL16R/L...			2.4	0.75	0.54	5.3				
1/4"-24UNS		24	M542TH24UNL16R/L...			1.7	0.75	0.61	18.35	41.2	5.1	MH...-5.0	
1/4"-20UNC		20	M542TH20UNL16R/L...			1.7	0.9	0.73	4.6				
5/16"-18UNC	6.0	18	M659TH18UNL16R/L...			2.9	1.05	0.81	18.5	42.2	6.3	MH...-6.0	
3/8"-16UNC		16	M659TH16UNL16R/L...	2.9	1	0.92	7.7						

* L2 Ref: Repeatability within +/-0.02.

Whitworth - BSW, BSP, BSF, BSB

External

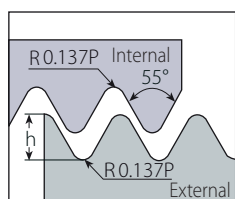

Defined by: B.S.84:1956, DIN 259, ISO228/1:1982
Tolerance class: Medium class A

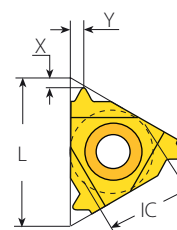

Standard

Standard

Insert Size		Pitch	Ordering Code		Dimensions mm			Anvil		Toolholder
IC	L mm	tpi	RH	LH	h min	X	Y	RH	LH	
1/4"	11	72	2ER72W...	2EL72W...	0.23	0.7	0.4	-	-	NL...-2 (LH)
		60	2ER60W...	2EL60W...	0.27	0.7	0.4			
		56	2ER56W...	2EL56W...	0.29	0.7	0.4			
		48	2ER48W...	2EL48W...	0.34	0.6	0.6			
		40	2ER40W...	2EL40W...	0.41	0.6	0.6			
		36	2ER36W...	2EL36W...	0.45	0.6	0.6			
		32	2ER32W...	2EL32W...	0.51	0.6	0.6			
		28	2ER28W...	2EL28W...	0.58	0.6	0.7			
		26	2ER26W...	2EL26W...	0.63	0.7	0.8			
		24	2ER24W...	2EL24W...	0.68	0.7	0.8			
		22	2ER22W...	2EL22W...	0.74	0.8	0.9			
		20	2ER20W...	2EL20W...	0.81	0.8	0.9			
		19	2ER19W...	2EL19W...	0.86	0.8	1.0			
		18	2ER18W...	2EL18W...	0.90	0.8	1.0			
3/8"	16	72	3ER72W...	3EL72W...	0.23	0.7	0.4	YE3	YI3	AL...-3 (LH)
		60	3ER60W...	3EL60W...	0.27	0.7	0.4			
		56	3ER56W...	3EL56W...	0.29	0.7	0.4			
		48	3ER48W...	3EL48W...	0.34	0.6	0.6			
		40	3ER40W...	3EL40W...	0.41	0.6	0.6			
		36	3ER36W...	3EL36W...	0.45	0.6	0.6			
		32	3ER32W...	3EL32W...	0.51	0.6	0.6			
		30	3ER30W...	3EL30W...	0.55	0.6	0.7			
		28	3ER28W...	3EL28W...	0.58	0.6	0.7			
		26	3ER26W...	3EL26W...	0.63	0.7	0.8			
		24	3ER24W...	3EL24W...	0.68	0.7	0.8			
		22	3ER22W...	3EL22W...	0.74	0.8	0.9			
		20	3ER20W...	3EL20W...	0.81	0.8	0.9			
		19	3ER19W...	3EL19W...	0.86	0.8	1.0			
		18	3ER18W...	3EL18W...	0.90	0.8	1.0			
		16	3ER16W...	3EL16W...	1.02	0.9	1.1			
		14	3ER14W...	3EL14W...	1.16	1.0	1.2			
		12	3ER12W...	3EL12W...	1.36	1.1	1.4			
11	3ER11W...	3EL11W...	1.48	1.1	1.5					
10	3ER10W...	3EL10W...	1.63	1.1	1.5					
9	3ER9W...	3EL9W...	1.81	1.2	1.7					
8	3ER8W...	3EL8W...	2.03	1.2	1.5					



Whitworth - BSW, BSP, BSF, BSB (con't)

External

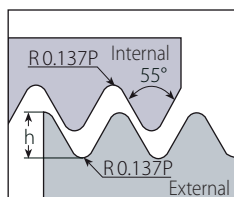

Defined by: B.S.84:1956,
DIN 259, ISO228/1:1982
Tolerance class: Medium class A

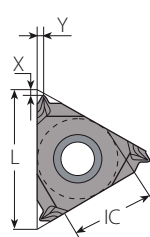

SCB
Sintered
Chipbreaker

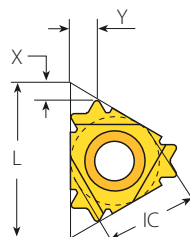

V6

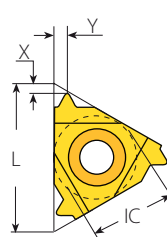

Standard

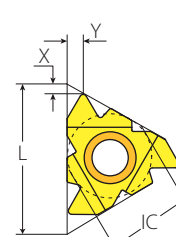



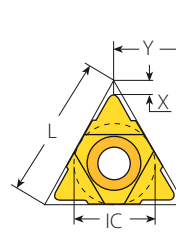

F-Line



U Style

Standard

Insert Size		Pitch	Ordering Code		Dimensions mm			Anvil		Toolholder	
IC	L mm	tpi	RH	LH	h min	X	Y	RH	LH		
 SCB	3/8" SCB	16	36	3JER36W...		0.45	1.2	0.5	YE3	-	AL...-3
			32	3JER32W...		0.51	1.2	0.5			
			28	3JER28W...		0.58	0.7	0.8			
			24	3JER24W...		0.68	0.7	0.8			
			20	3JER20W...		0.81	0.7	0.8			
			19	3JER19W...		0.86	0.7	0.8			
			18	3JER18W...		0.90	0.8	0.8			
			16	3JER16W...		1.02	0.8	0.8			
			14	3JER14W...		1.16	1.3	1.5			
			12	3JER12W...		1.36	1.3	1.5			
			11	3JER11W...		1.48	1.3	1.5			
			10	3JER10W...		1.63	1.3	1.5			
8	3JER8W...		2.03	1.3	1.5						
 V6	3/8" V6	16	19	3ER19W-6C...		0.86	1.8	2.2	YE3-6C	-	AL...-3
			16	3ER16W-6C...		1.02	1.6	2.4			
			14	3ER14W-6C...		1.16	1.8	2.7			
 F-Line	1/2"	22	7	4ER7W...	4EL7W...	2.41	1.6	2.3	YE4	Y14	AL...-4 (LH)
			6	4ER6W...	4EL6W...	2.71	1.6	2.3			
 F-Line	1/2" ^F	23	7	4FER7W...		2.41	1.6	2.6	YE4F		AL...-4F
			6	4FER6W...		2.71	1.6	2.3			
 F-Line	5/8"	27	4.5	5ER4.5W...	5EL4.5W...	3.61	1.8	2.6	YE5	Y15	AL...-5 (LH)
			4	5ER4W...	5EL4W...	4.07	2.0	2.9			

U Style

Insert Size		Pitch	Ordering Code		Dimensions mm			Anvil		Toolholder	
IC	L mm	tpi	RH+LH		h min	X	Y	RH	LH		
	1/2" ^U	22	4.5	4UEI4.5W...		3.61	2.3	11.0	YE4U	Y14U	AL...-4U (LH)
			4	4UEI4W...		4.07	1.8	11.0			
			3.5	4UEI3.5W...		4.65	2.1	11.0			
			3.25	4UEI3.25W...		5.00	2.0	11.0			
5/8" ^U	27	27	3.5	5UEI3.5W...		4.65	2.1	13.7	YE5U	Y15U	AL...-5U (LH)
			3.25	5UEI3.25W...		5.00	2.0	13.7			
			3	5UEI3W...		5.42	2.3	13.7			
			2.75	5UEI2.75W...		5.91	2.4	13.7			

Whitworth - BSW, BSP, BSF, BSB (con't)

External

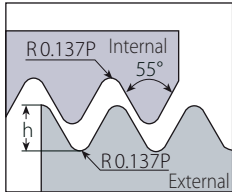

Defined by: B.S.84:1956, DIN 259, ISO228/1:1982
Tolerance class: Medium class A

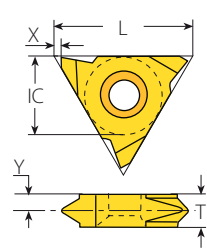

V Style / Slim Throat

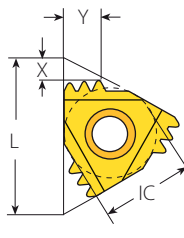

M+ Style

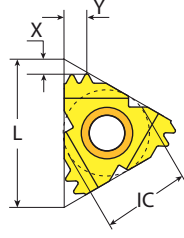

F-Line M+

Slim Throat



Insert Size		Pitch	Ordering Code		Dimensions mm				Toolholder
IC	L mm	tpi	RH	LH	h min	X	Y	T	
1/4"V	11	19	2VER19W...	2VEL19W...	0.86	0.69	2.3	3.2	NL...-2V (LH)
		14	2VER14W...	2VEL14W...	1.16	0.69	2.0	3.2	
		11	2VER11W...	2VEL11W...	1.48	0.69	1.7	3.2	
3/8"V	16	19	3VER19W...	3VEL19W...	0.86	1.1	2.7	3.6	NL...-3V (LH)
		18	3VER18W...	3VEL18W...	0.90	1.1	2.6	3.6	
		16	3VER16W...	3VEL16W...	1.02	1.1	2.6	3.6	
		14	3VER14W...	3VEL14W...	1.16	1.1	2.4	3.6	
		12	3VER12W...	3VEL12W...	1.36	1.1	2.2	3.6	
		11	3VER11W...	3VEL11W...	1.48	1.1	2.1	3.6	

V Style



Insert Size		Pitch	Ordering Code		Dimensions mm				Toolholder
IC	L mm	tpi	RH	LH	h min	X	Y	T	
5/8"V	27	4	5VER4W...	5VEL4W...	4.07	1.0	3.3	6	NL...-5V-6 (LH)
		3	5VER3W...	5VEL3W...	5.42	1.0	4.3	8	NL...-5V-8 (LH)
		2.5	5VER2.5W...	5VEL2.5W...	6.51	1.0	5.2	10	NL...-5V-10 (LH)

M+ Style



F.LINE

Insert Size		Pitch	Teeth	Ordering Code		Dimensions mm			Anvil	Toolholder
IC	L mm	tpi		RH	h min	X	Y	RH		
3/8"	16	28	2	3ER28W2M+...	0.58	1.2	1.6	YE3M	AL...-3	
		19	2	3ER19W2M+...	0.86	1.6	2.3			
		19	3	3ER19W3M+...	0.86	2.2	3.4			
		14	2	3ER14W2M+...	1.16	2.0	3.0			
1/2"	22	14	3	4ER14W3M+...	1.16	2.9	4.6	YE4M	AL...-4	
		11	2	4ER11W2M+...	1.48	2.3	3.5			
1/2"F	23	11	2	4FER11W2M+...	1.48	2.3	3.5	YE4M2F	AL...-4MF	

Whitworth - BSW, BSP, BSF, BSB (con't)

External

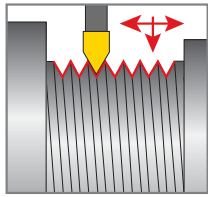
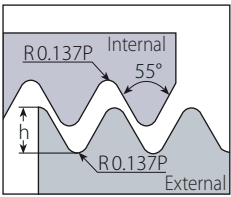

Defined by: B.S.84:1956, DIN 259, ISO228/1:1982
Tolerance class: Medium class A

RS/LS Varied range of threading standards for machining between shoulders and close to spindle.

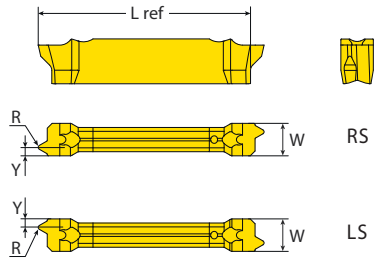

VG-Cut



Pocket Size	Ordering Code	Dimensions mm					No. of Passes	Helix	Min. Thread Diameter	Toolholder
		RH	W ref	Pitch tpi	h min	Y				
3	VGD3.0W19RH-RS/LS...		3.00	19	0.86	0.95	21.9	2.5°	1/2"-19BSW	Monoblock VGE...T12
	VGD3.0W14RH-RS/LS...			14	1.16	1.15			8 - 14	

LH Helix threads available upon request.

Whitworth - BSW, BSP, BSF, BSB (con't)

Internal

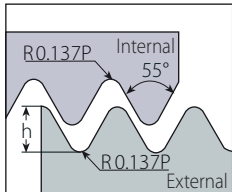

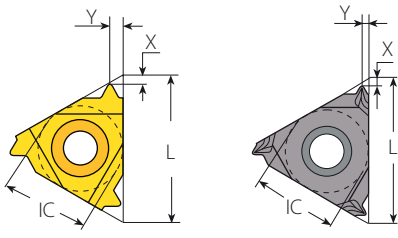

Defined by: B.S.84:1956, DIN 259, ISO228/1:1982
Tolerance class: Medium class A



Standard

SCB
Sintered
Chipbreaker

Standard

Insert Size		Pitch	Ordering Code		Dimensions mm			Anvil		Toolholder	
IC	L mm	tpi	RH	LH	h min	X	Y	RH	LH		
	1/4"	11	72	2IR72W...	2IL72W...	0.23	0.7	0.4	-	-	NVR...-2 (LH)
			60	2IR60W...	2IL60W...	0.27	0.7	0.4			
			56	2IR56W...	2IL56W...	0.29	0.7	0.4			
			48	2IR48W...	2IL48W...	0.34	0.6	0.6			
			40	2IR40W...	2IL40W...	0.41	0.6	0.6			
			36	2IR36W...	2IL36W...	0.45	0.6	0.6			
			32	2IR32W...	2IL32W...	0.51	0.6	0.6			
			28	2IR28W...	2IL28W...	0.58	0.6	0.7			
			26	2IR26W...	2IL26W...	0.63	0.7	0.8			
			24	2IR24W...	2IL24W...	0.68	0.7	0.8			
			22	2IR22W...	2IL22W...	0.74	0.8	0.9			
			20	2IR20W...	2IL20W...	0.81	0.8	0.9			
			19	2IR19W...	2IL19W...	0.86	0.8	1.0			
			18	2IR18W...	2IL18W...	0.90	0.8	1.0			
16	2IR16W...	2IL16W...	1.02	0.9	1.1						
14	2IR14W...	2IL14W...	1.16	0.9	1.1						
12	2IR12W...	2IL12W...	1.32	0.9	1.2						
	1/4" SCB	11	36	2JIR36W...		0.45	1.2	0.5	-	-	NVR...-2
			32	2JIR32W...		0.51	1.2	0.5			
			28	2JIR28W...		0.58	0.7	0.8			
			24	2JIR24W...		0.68	0.7	0.8			
			20	2JIR20W...		0.81	0.7	0.8			
			19	2JIR19W...		0.86	0.6	0.8			
			18	2JIR18W...		0.90	0.8	0.8			
			16	2JIR16W...		1.02	0.8	0.8			
14	2JIR14W...		1.16	0.7	0.9						
	3/8"	16	72	3IR72W...	3IL72W...	0.23	0.7	0.4	Y13	YE3	AVR...-3 (LH)
			60	3IR60W...	3IL60W...	0.27	0.7	0.4			
			56	3IR56W...	3IL56W...	0.29	0.7	0.4			
			48	3IR48W...	3IL48W...	0.34	0.6	0.6			
			40	3IR40W...	3IL40W...	0.41	0.6	0.6			
			36	3IR36W...	3IL36W...	0.45	0.6	0.6			
			32	3IR32W...	3IL32W...	0.51	0.6	0.6			
			30	3IR30W...	3IL30W...	0.55	0.6	0.7			

Whitworth - BSW, BSP, BSF, BSB (con't)



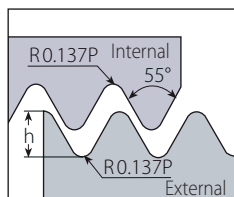

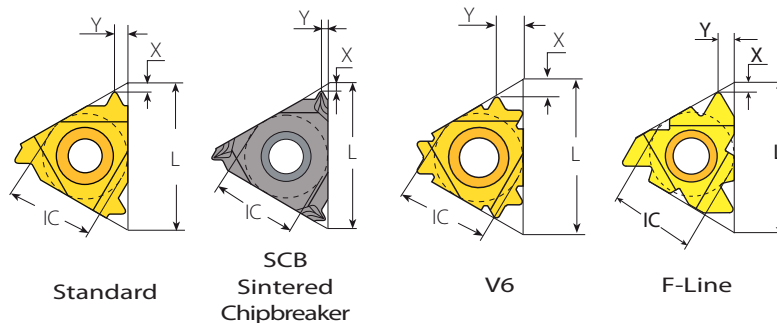

Internal



Defined by: B.S.84:1956, DIN 259, ISO228/1:1982
Tolerance class: Medium class A



Standard

Insert Size		Pitch	Ordering Code		Dimensions mm			Anvil		Toolholder	
IC	L mm	tpi	RH	LH	h min	X	Y	RH	LH		
	3/8"	16	28	3IR28W...	3IL28W...	0.58	0.6	0.7	Y13	YE3	AVR...-3 (LH)
			26	3IR26W...	3IL26W...	0.63	0.7	0.8			
			24	3IR24W...	3IL24W...	0.68	0.7	0.8			
			22	3IR22W...	3IL22W...	0.74	0.8	0.9			
			20	3IR20W...	3IL20W...	0.81	0.8	0.9			
			19	3IR19W...	3IL19W...	0.86	0.8	1.0			
			18	3IR18W...	3IL18W...	0.90	0.8	1.0			
			16	3IR16W...	3IL16W...	1.02	0.9	1.1			
			14	3IR14W...	3IL14W...	1.16	1.0	1.2			
			12	3IR12W...	3IL12W...	1.36	1.1	1.4			
			11	3IR11W...	3IL11W...	1.48	1.1	1.5			
			10	3IR10W...	3IL10W...	1.63	1.1	1.5			
9	3IR9W...	3IL9W...	1.81	1.2	1.7						
8	3IR8W...	3IL8W...	2.03	1.2	1.5						
	3/8" SCB	16	28	3JIR28W...		0.58	0.7	0.8	Y13	-	AVR...-3
			24	3JIR24W...		0.68	0.7	0.8			
			20	3JIR20W...		0.81	0.7	0.8			
			19	3JIR19W...		0.86	0.6	0.5			
			18	3JIR18W...		0.90	0.8	0.8			
			16	3JIR16W...		1.02	0.8	0.8			
			14	3JIR14W...		1.16	1.3	1.5			
			12	3JIR12W...		1.36	1.3	1.5			
	3/8" V6	16	19	3IR19W-6C...		0.86	1.7	2.2	Y13-6C	-	AVR...-3 NVRC...-3 206/...
			16	3IR16W-6C...		1.02	1.6	2.6			
			14	3IR14W-6C...		1.16	1.8	2.7			
			12	3IR12W-6C...		1.36	1.7	2.6			
	1/2"	22	7	4IR7W...	4IL7W...	2.41	1.6	2.3	Y14	YE4	AVR...-4 (LH)
			6	4IR6W...	4IL6W...	2.71	1.6	2.3			
			5	4IR5W...	4IL5W...	3.25	1.7	2.4			
	1/2" F	23	7	4FIR7W...		2.41	1.6	2.3	Y14F		AVRC...-4F
			6	4FIR6W...		2.71	1.6	2.3			
			5	4FIR5W...		3.25	1.7	2.4			
	5/8"	27	4.5	5IR4.5W...	5IL4.5W...	3.61	1.8	2.6	Y15	YE5	AVR...-5 (LH)
			4	5IR4W...	5IL4W...	4.07	2.0	2.9			

Whitworth - BSW, BSP, BSF, BSB (con't)

Internal

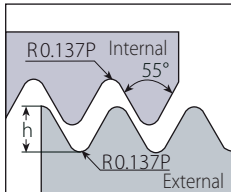

Defined by: B.S.84:1956, DIN 259, ISO228/1:1982
Tolerance class: Medium class A

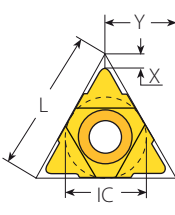

U Style

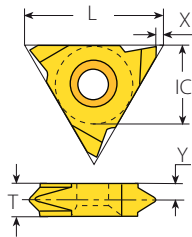

V Style

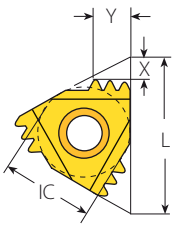

M+ Style

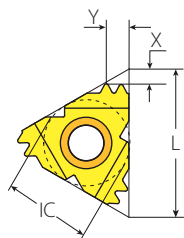

F-Line M+

U Style

	Insert Size		Pitch	Ordering Code		Dimensions mm			Anvil		Toolholder
	IC	L mm		RH+LH		h min	X	Y	RH	LH	
	1/2"U	22	4.5	4UEI4.5W...	3.61	2.3	11.0	YI4U	YE4U	AVR...-4U (LH)	
			4	4UEI4W...	4.07	1.8	11.0				
			3.5	4UEI3.5W...	4.65	2.1	11.0				
			3.25	4UEI3.25W...	5.00	2.0	11.0				
	5/8"U	27	3.5	5UEI3.5W...	4.65	2.1	13.7	YI5U	YE5U	AVR...-5U (LH)	
			3.25	5UEI3.25W...	5.00	2.0	13.7				
			3	5UEI3W...	5.42	2.3	13.7				
			2.75	5UEI2.75W...	5.91	2.4	13.7				

V Style

	Insert Size		Pitch	Ordering Code		Dimensions mm				Toolholder
	IC	L mm		RH	LH	h min	X	Y	T	
	5/8"V	27	4	5VIR4W...	5VIL4W...	4.07	1.0	3.3	6	NVR...-5V (LH)
			3	5VIR3W...	5VIL3W...	5.42	1.0	4.3	8	
			2.5	5VIR2.5W...	5VIL2.5W...	6.51	1.0	5.2	10	

M+ Style

	Insert Size		Pitch	Teeth	Ordering Code		Dimensions mm			Anvil	
	IC	L mm			RH		h min	X	Y	RH	Toolholder
	3/8"	16	14	2	3IR14W2M+...	1.16	2.0	3.0	YI3M	AVR...-3	
	1/2"	22	11	2	4IR11W2M+...	1.48	2.3	3.5	YI4M	AVR...-4	
	1/2"F	23	11	2	4FIR11W2M+...	1.48	2.3	3.5	YI4M2F	AVRC...-4MF	

FLINE

Multiplus

Whitworth - BSW, BSP, BSF, BSB (con't)

Mini-V

Internal

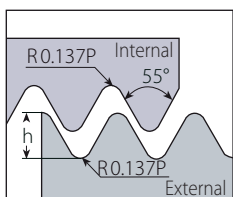

Defined by: B.S.84:1956, DIN 259, ISO228/1:1982
Tolerance class: Medium Class A

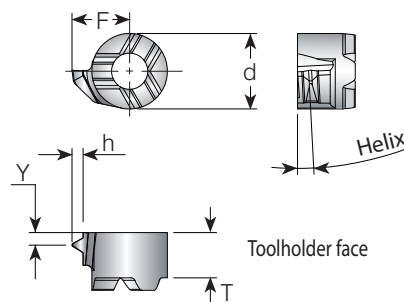

Mini-V



Min. Thread	Insert Style	Pitch	Ordering Code	Dimensions mm						Helix	Toolholder
				tpi	RH	d	T	F	Y		
1/2"x19W	V11	19	V11TH19WR...	8	4.2	6.18	0.8	0.86	2	.V11-...	

Internal

Defined by: B.S.84:1956, DIN 259, ISO228/1:1982
Tolerance class: Medium class A

Mini-3 Standard

Insert Size		Pitch	Ordering Code		Dimensions mm			Min. Bore Dia.	Toolholder
IC mm	L mm	tpi	RH	LH	h min	Y	F	mm	
4.0	6	26	4.0KIR26W...	4.0KIL26W...	0.63	0.6	3.6	6.25	.NVR.5-4.0K (LH)
		22	4.0KIR22W...	4.0KIL22W...	0.74	0.6	3.7	6.35	
		20	4.0KIR20W...	4.0KIL20W...	0.81	0.7	3.7	6.35	
		19	4.0KIR19W...	4.0KIL19W...	0.86	0.7	3.7	6.35	
		18	4.0KIR18W...	4.0KIL18W...	0.90	0.7	3.7	6.35	
5.0	8	28	5.0KIR28W...	5.0KIL28W...	0.58	0.6			.NVRC 7-5.0K (LH)
		24	5.0KIR24W...	5.0KIL24W...	0.68	0.6			
		20	5.0KIR20W...	5.0KIL20W...	0.81	0.7	4.7	7.8	
		19	5.0KIR19W...	5.0KIL19W...	0.86	0.7			
		18	5.0KIR18W...	5.0KIL18W...	0.90	0.7			
6.0	10	28	6.0IR28W...		0.58	0.7	4.7	9.6	.NVR1.-6.0
		19	6.0IR19W...		0.86	1.0	5.0	9.9	
		14	6.0IR14W...		1.16	1.1	5.3	10.0	

Left handed tool supplied by request (Example: 6.0L28W.....).

Mini-3 U Style

Insert Size		Pitch	Ordering Code		Dimensions mm			Min. Bore Dia.	Toolholder
IC mm	L mm	tpi	RH+LH	h min	Y	F	mm		
5.0U	8	14	5.0KUI14W...	1.16		5.6		.NVRC 8-5.0KU (LH)	
		12	5.0KUI12W...	1.36	4.0	5.7	9.0		
		11	5.0KUI11W...	1.48		5.7			

Mini-L

Insert Size		Pitch	Ordering Code		Dimensions mm			Min. Bore Dia.	Toolholder
IC mm		tpi	RH	LH	h min	Y	F	mm	
5.0 L		28	5LIR28W...		0.58	0.7	4.05	7.6	.NVR 10. -5L
		19	5LIR19W...		0.86	1.0	4.35	7.9	
		14	5LIR14W...		1.16	1.1	4.68	8.0	

Left handed tool supplied by request (Example: 5LIL28W...).

Whitworth - BSW, BSP, BSF, BSB (con't)

MINIPRO

Internal

Defined by: B.S.84:1956,
DIN 259, ISO228/1:1982
Tolerance class: Medium class A

RH-Single Ended **RH-Double Ended**

Micro - Double Ended

Thread	Insert Dia.	Pitch	Ordering Code	Dimensions mm					Min. Bore Dia.	Toolholder
	d mm	tpi	RH	L1	L	F	Y	h min	mm	
1/16"-28BSP	4.0	28	4.0SIR28W...	16	50	1.86	0.65	0.58	4.2	SMC...-4.0
1/4"-26BSF		26	4.0SIR26W...	16	50	1.93	0.75	0.63	4.2	
1/4"-24BSW		24	4.0SIR24W...	16	50	1.96	0.75	0.68	4.3	
1/16"-28BSP	6.0	28	6.0SIR28W...	16	50	2.50	0.65	0.58	6.0	SMC...-6.0
5/16"-28BSW		26	6.0SIR26W...	16	50	2.50	0.75	0.63	6.0	
5/16"-24BSW		24	6.0SIR24W...	16	50	2.50	0.75	0.68	6.0	
5/16"-22BSW		22	6.0SIR22W...	16	50	2.50	0.90	0.74	6.0	
3/8"-20BSF	6.0	20	6.0SIR20W...	16	50	2.50	0.90	0.81	6.0	SMC...-6.0
1/4"-19BSP		19	6.0SIR19W...	16	50	2.50	0.95	0.86	6.0	

Left handed tool supplied by request (Example: 6.0SIL19W...).

Micro - Single Ended

microscope

Thread	Insert Dia..	Pitch	Ordering Code	Dimensions mm								Min. Bore Dia.	Toolholder
	d mm	tpi	RH/LH	Helix °	L1	F	Y	h min	L2 ref*	L ref	D mm		
1/16"-28BSP	6.0	28	M659TH28WL16R/L...	3.5	16	2.9	0.65	0.58	18.5	42.2	6.5	MH...-6.0	
1/4"-19BSP		19	M659TH19WL16R/L...				0.95	0.86			11.4		

* L2 Ref: Repeatability within +/-0.02.

BSPT

External

Defined by: B.S. 21:1985
Tolerance class: Standard BSPT

Standard **SCB Sintered Chipbreaker** **V6** **Slim Throat**

Standard



Insert Size		Pitch	Ordering Code		Dimensions mm			Anvil		Toolholder
IC	L mm	tpi	RH	LH	h min	X	Y	RH	LH	
1/4"	11	28	2ER28BSPT...	2EL28BSPT...	0.58	0.6	0.6	-	-	NL...-2 (LH)
		19	2ER19BSPT...	2EL19BSPT...	0.86	0.8	0.9	-	-	
		14	2ER14BSPT...	2EL14BSPT...	1.16	0.9	1.0	-	-	
3/8"	16	28	3ER28BSPT...	3EL28BSPT...	0.58	0.6	0.6	YE3	YI3	AL...-3 (LH)
		19	3ER19BSPT...	3EL19BSPT...	0.86	0.8	0.9			
		14	3ER14BSPT...	3EL14BSPT...	1.16	1.0	1.2			
		11	3ER11BSPT...	3EL11BSPT...	1.48	1.1	1.5			
3/8" SCB	16	28	3JER28BSPT...		0.58	0.7	0.8	YE3	-	AL...-3
		19	3JER19BSPT...		0.86	0.7	0.8			
		14	3JER14BSPT...		1.16	1.3	1.5			
3/8" V6	16	19	3ER19BSPT-6C...		0.86	1.7	2.2	YE3-6C	-	AL...-3
		14	3ER14BSPT-6C...		1.16	1.9	2.8			

Slim Throat



Insert Size		Pitch	Ordering Code		Dimensions mm				Toolholder
IC	L mm	tpi	RH	LH	h min	X	Y	T	
3/8"V	16	28	3VER28BSPT...	3VEL28BSPT...	0.58	1.1	3.0	3.6	NL...-3V (LH)
		19	3VER19BSPT...	3VEL19BSPT...	0.86	1.1	2.7	3.6	
		14	3VER14BSPT...	3VEL14BSPT...	1.16	1.1	2.4	3.6	
		11	3VER11BSPT...	3VEL11BSPT...	1.48	1.1	2.1	3.6	

BSPT (con't)

Internal

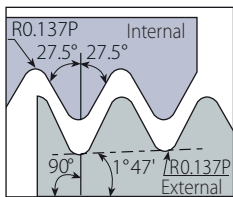

Defined by: B.S. 21:1985
Tolerance class: Standard BSPT

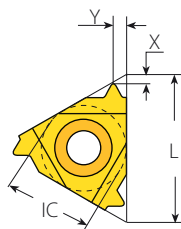

Standard

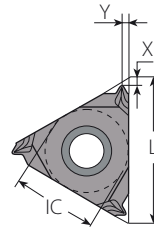

SCB
Sintered
Chipbreaker

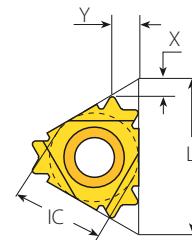

V6

Standard



SCB



V6

Insert Size		Pitch	Ordering Code		Dimensions mm			Anvil		Toolholder
IC	L mm	tpi	RH	LH	h min	X	Y	RH	LH	
1/4"	11	28	2IR28BSPT...	2IL28BSPT...	0.58	0.6	0.6	-	-	NVR...-2 (LH)
		19	2IR19BSPT...	2IL19BSPT...	0.86	0.8	0.9	-	-	
		14	2IR14BSPT...	2IL14BSPT...	1.16	0.9	1.0	-	-	
1/4" SCB	11	28	2JIR28BSPT...		0.58	0.7	0.8	-	-	NVR...-2
		19	2JIR19BSPT...		0.86	0.7	0.8	-	-	
3/8"	16	28	3IR28BSPT...	3IL28BSPT...	0.58	0.6	0.6	Y13	YE3	AVR...-3 (LH)
		19	3IR19BSPT...	3IL19BSPT...	0.86	0.8	0.9			
		14	3IR14BSPT...	3IL14BSPT...	1.16	1.0	1.2			
		11	3IR11BSPT...	3IL11BSPT...	1.48	1.1	1.5			
3/8" SCB	16	28	3JIR28BSPT...		0.58	0.7	0.8	Y13	-	AVR...-3
		19	3JIR19BSPT...		0.86	0.7	0.8			
		14	3JIR14BSPT...		1.16	1.3	1.5			
		11	3JIR11BSPT...		1.48	1.3	1.5			
3/8" V6	16	19	3IR19BSPT-6C...		0.86	1.8	2.3	Y13-6C	-	AVR...-3 NVR...-3 206/...
		14	3IR14BSPT-6C...		1.16	1.9	2.7			

BSPT

Mini-V

Internal

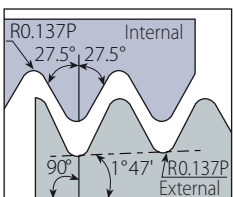

Defined by: B.S.21:1985
Tolerance class: Standard BSPT

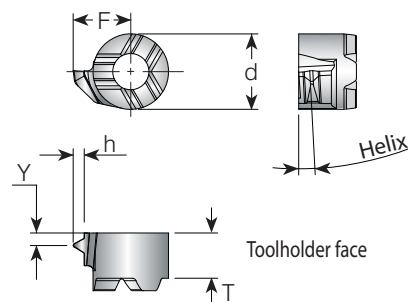

Mini-V



Min. Thread	Insert Style	Pitch	Ordering Code		Dimensions mm				Helix	Toolholder
		tpi	RH	d	T	F	Y	h min	Deg.	
1/4"-19BSPT	V11	19	V11TH19BSPTR...	8	4.2	6.13	0.9	0.86	2.5	.V11...

BSPT (con't)



Internal

Defined by: B.S. 21:1985
Tolerance class: Standard BSPT

Mini-3 Standard

Insert Size	Pitch		Ordering Code		Dimensions mm			Min. Bore Dia.	Toolholder
	IC mm	L mm	tpi	RH	LH	h min	Y	F	
4.0	6	28	4.0KIR28BSPT...	4.0KIL28BSPT...	0.58	0.6	3.6	6.25	.NVR.5-4.0K (LH)
		19	5.0KIR19BSPT...	5.0KIL19BSPT...	0.86	0.7	4.7	7.8	.NVRC 7-5.0K (LH)
6.0	10	28	6.0IR28BSPT...		0.58	0.6	4.7	9.6	.NVR1..-6.0
		19	6.0IR19BSPT...		0.86	0.9	5.0	9.9	
		14	6.0IR14BSPT...		1.16	1.2	5.3	10.0	

Left handed tool supplied by request (Example: 6.0L28BSPT...).

Mini-L

Insert Size	Pitch		Ordering Code		Dimensions mm			Min. Bore Dia.	Toolholder
	IC mm	tpi	RH	LH	h min	Y	F	mm	
5.0L	5.0L	28	5LIR28BSPT...		0.58	0.6	4.05	7.6	.NVR10. -5L
		19	5LIR19BSPT...		0.86	0.9	4.35	7.9	
		14	5LIR14BSPT...		1.16	1.2	4.68	8.0	

Left handed tool supplied by request (Example:5LIL28BSPT...).

NPT

External

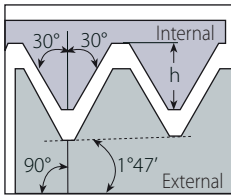

Defined by: USAS B2.1:1968
Tolerance class: Standard NPT

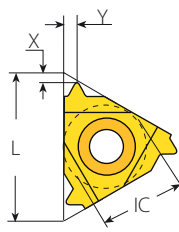

Standard

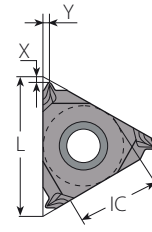

SCB
Sintered
Chipbreaker

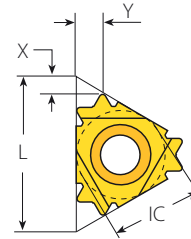

V6

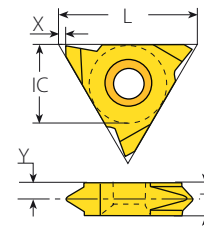

Slim Throat

Standard



SCB



V6

Insert Size		Pitch	Ordering Code		Dimensions mm			Anvil		Toolholder
IC	L mm	tpi	RH	LH	h min	X	Y	RH	LH	
1/4"	11	27	2ER27NPT...	2EL27NPT...	0.66	0.7	0.8	-	-	NL...-2 (LH)
		18	2ER18NPT...	2EL18NPT...	1.01	0.8	1.0			
		14	2ER14NPT...	2EL14NPT...	1.33	0.8	1.0			
3/8"	16	27	3ER27NPT...	3EL27NPT...	0.66	0.7	0.8	YE3	YI3	AL...-3 (LH)
		18	3ER18NPT...	3EL18NPT...	1.01	0.8	1.0			
		14	3ER14NPT...	3EL14NPT...	1.33	0.9	1.2			
		11.5	3ER11.5NPT...	3EL11.5NPT...	1.64	1.1	1.5			
3/8" SCB	16	8	3ER8NPT...	3EL8NPT...	2.42	1.3	1.8	YE3	-	AL...-3
		27	3JER27NPT...		0.66	0.6	0.8			
		18	3JER18NPT...		1.01	0.6	0.8			
		14	3JER14NPT...		1.33	1.1	1.5			
3/8" V6	16	11.5	3JER11.5NPT...		1.64	1.1	1.5	YE3-6C	-	AL...-3
		8	3JER8NPT...		2.42	1.0	1.5			

Slim Throat



Insert Size		Pitch	Ordering Code		Dimensions mm				Toolholder
IC	L mm	tpi	RH	LH	h min	X	Y	T	
1/4"V	11	27	2VER27NPT...	2VEL27NPT...	0.66	0.7	2.0	3.2	NL...-2V (LH)
		18	2VER18NPT...	2VEL18NPT...	1.01	0.7	1.8	3.2	
		14	2VER14NPT...	2VEL14NPT...	1.33	0.7	1.8	3.2	
		11.5	2VER11.5NPT...	2VEL11.5NPT...	1.64	0.7	2.1	3.2	
3/8"V	16	27	3VER27NPT...	3VEL27NPT...	0.66	1.1	2.9	3.6	NL...-3V (LH)
		18	3VER18NPT...	3VEL18NPT...	1.01	1.1	2.6	3.6	
		11.5	3VER11.5NPT...	3VEL11.5 NPT...	1.64	1.1	2.1	3.6	

NPT (con't)

External

Defined by: USAS B2.1:1968
Tolerance class: Standard NPT

RS/LS Varied range of threading standards for machining between shoulders and close to spindle.

VG-Cut

Pocket Size	Ordering Code	Dimensions mm					No. of Passes	Helix	Min. Thread Diameter	Toolholder
		RH	W ref	Pitch tpi	h min	Y				
3	VGD3.0NPT18RH-RS/LS...			18	1.01	1.20	7 - 12		1/4"-18NPT	Monoblock
3	VGD3.0NPT14RH-RS/LS...	3.00		14	1.33	1.40	8 - 14	1.5°	1/2"-14NPT	VGE...T12
3	VGD3.0NPT11.5RH-RS/LS...			12	1.64	1.60	9 - 15		1"-11.5NPT	

LH Helix threads available upon request.

NPT (con't)

External

Defined by: USAS B2.1:1968
Tolerance class: Standard NPT

M+ Style
F-Line M+
Z+ Style

M+ Style



Insert Size	Pitch		Teeth	Ordering Code	Dimensions mm			Anvil	
	IC	L mm			tpi	RH	h min	X	Y
3/8"	16	14	2	3ER14NPT2M+...	1.33	2.0	3.0	YE3M	AL..-3
1/2"	22	11.5	2	4ER11.5NPT2M+...	1.64	2.2	3.4	YE4M	AL..-4
1/2"F	23	11.5	2	4FER11.5NPT2M+...	1.64	2.2	3.4	YE4M2F	AL...-4MF
5/8"	27	11.5	3	5ER11.5NPT3M+...	1.64	3.5	5.6	YE5M	AL..-5M
		8	2	5ER8NPT2M+...	2.42	3.1	4.9		



FLINE

Z+ Style



Insert Size	Pitch		Teeth	Ordering Code	Dimensions mm			Anvil	
	IC	L mm			tpi	RH	h min	X	Y
1/2"	22	11.5	2	4ER11.5NPT2Z+...	1.64	2.7	10.0	YE4Z	AL..-4Z
		8	2	4ER8NPT2Z+...	2.42	3.4	9.6		



NPT (con't)

Internal

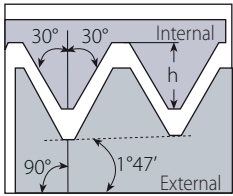

Defined by: USAS B2.1:1968
Tolerance class: Standard NPT

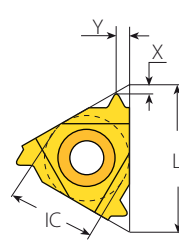

Standard

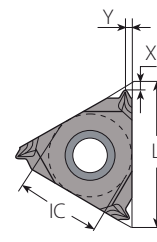

SCB
Sintered
Chipbreaker

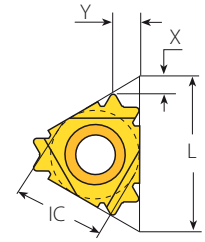

V6

Standard



SCB



V6

Insert Size		Pitch	Ordering Code		Dimensions mm			Anvil		Toolholder
IC	L mm	tpi	RH	LH	h min	X	Y	RH	LH	
1/4"	11	27	2IR27NPT...	2IL27NPT...	0.66	0.7	0.8	-	-	NVR..-2 (LH)
		18	2IR18NPT...	2IL18NPT...	1.01	0.8	1.0			
		14	2IR14NPT...	2IL14NPT...	1.33	0.8	1.0			
1/4" SCB	11	27	2JIR27NPT...		0.66	0.6	0.8	-	-	NVR..-2
		18	2JIR18NPT...		1.01	0.6	0.8			
3/8"	16	27	3IR27NPT...	3IL27NPT...	0.66	0.7	0.8	YI3	YE3	AVR..-3 (LH)
		18	3IR18NPT...	3IL18NPT...	1.01	0.8	1.0			
		14	3IR14NPT...	3IL14NPT...	1.33	0.9	1.2			
		11.5	3IR11.5NPT...	3IL11.5NPT...	1.64	1.1	1.5			
3/8" SCB	16	8	3IR8NPT...	3IL8NPT...	2.42	1.3	1.8	YI3	-	AVR..-3
		27	3JIR27NPT...		0.66	0.6	0.8			
		18	3JIR18NPT...		1.01	0.6	0.8			
		14	3JIR14NPT...		1.33	1.1	1.5			
3/8" V6	16	11.5	3JIR11.5NPT...		1.64	1.1	1.5	YI3-6C	-	AVR..-3 NVR..-3 206/...
		8	3JIR8NPT...		2.42	1.0	1.5			

NPT (con't)

Internal

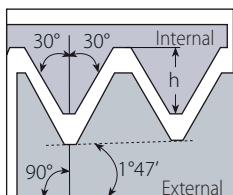

Defined by: USAS B2.1:1968
Tolerance class: Standard NPT

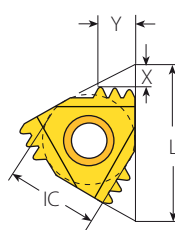

M+ Style

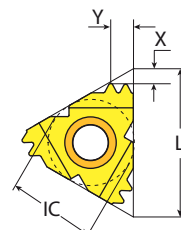

F-Line M+

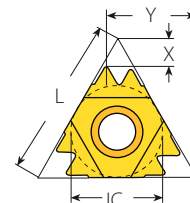

Z+ Style

M+ Style

Multiplus



FLINE

Insert Size		Pitch	Teeth	Ordering Code	Dimensions mm			Anvil	Toolholder
IC	L mm	tpi		RH	h min	X	Y	RH	
3/8"	16	14	2	3IR14NPT2M+...	1.33	2.0	3.0	YI3M	AVR...-3
1/2"	22	11.5	2	4IR11.5NPT2M+...	1.64	2.2	3.4	YI4M	AVR...-4
1/2"F	23	11.5	2	4FIR11.5NPT2M+...	1.64	2.2	3.4	YI4M2F	AVRC...-4MF
5/8"	27	11.5	3	5IR11.5NPT3M+...	1.64	3.5	5.6	YI5M	AVR...-5M
		8	2	5IR8NPT2M+...	2.42	3.1	4.9		

Z+ Style

Multiplus



Insert Size		Pitch	Teeth	Ordering Code	Dimensions mm			Anvil	Toolholder
IC	L mm	tpi		RH	h min	X	Y	RH	
1/2"	22	11.5	2	4IR11.5NPT2Z+...	1.64	2.7	10.0	YI4Z	AVR...-4Z
		8	2	4IR8NPT2Z+...	2.42	3.4	9.6		

NPT (con't)

Mini-V

Internal

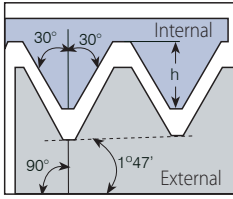

Defined by: USAS B2.1:1968
Tolerance class: Standard NPT

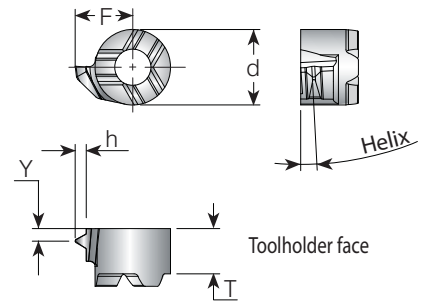

Mini-V



Min. Thread	Insert Style	Pitch	Ordering Code	Dimensions mm				Helix	Toolholder
		tpi	RH	d	T	F	Y	h min	Deg.
1/8"-27NPT	V08	27	V08TH27NPTR...	6	3.8	4.35	0.6	0.64	2
1/4"-18NPT		18	V08TH18NPTR...			4.8	0.9	1.0	2

NPT

MINIPRO

Internal

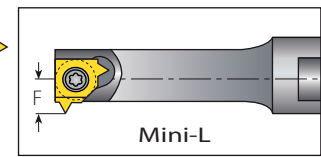
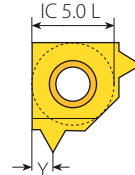
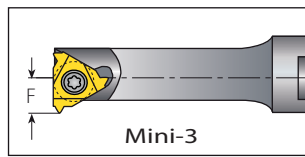
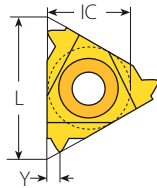
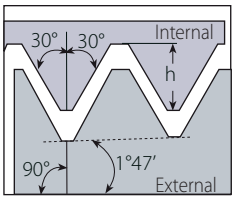

Defined by: USAS B2.1:1968
Tolerance class: Standard NPT

Mini-3 Standard

Insert Size		Pitch	Ordering Code		Dimensions mm			Min. Bore Dia.	Toolholder
IC mm	L mm	tpi	RH	LH	h min	Y	F	mm	
4.0	6.0	27	4.0KIR27NPT...	4.0KIL27NPT...	0.66	0.6	3.7	6.35	.NVR.5-4.0K (LH)
		27	5.0KIR27NPT...	5.0KIL27NPT...	0.66	0.6	4.7		
5.0	8	18	5.0KIR18NPT...	5.0KIL18NPT...	1.01	0.8	4.7	7.8	.NVR.7-5.0K (LH)
		27	6.0IR27NPT...		0.66	0.8	5.3		
6.0	10	18	6.0IR18NPT...		1.01	1.0	5.3	10.0	.NVR1.-6.0
		14	6.0IR14NPT...		1.33	1.1	5.3		

Left handed tool supplied by request (Example: 6.0IL27NPT...).

Mini-L

Insert Size		Pitch	Ordering Code		Dimensions mm			Min. Bore Dia.	Toolholder
IC mm		tpi	RH	LH	h min	Y	F	mm	
5.0L		27	5LIR27NPT...		0.66	0.8	4.65	8.0	.NVR10.-5L
		18	5LIR18NPT...		1.01	1.0	4.65		
		14	5LIR14NPT...		1.33	1.1	4.65		

Left handed tool supplied by request (Example: 5LIL27NPT...).

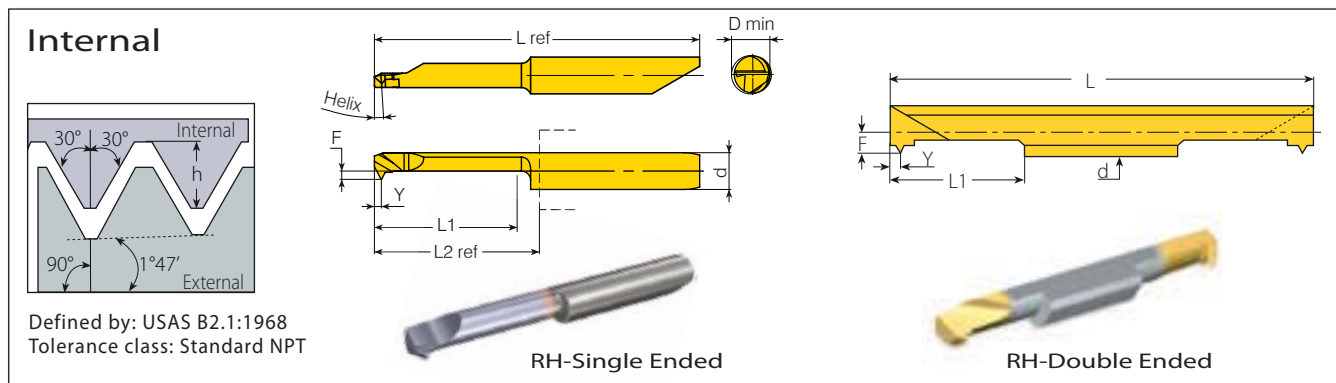
NPT (con't)
MINIPRO

Micro - Double Ended

	Insert Dia.	Pitch	Ordering Code	Dimensions mm					Min. Bore Dia.	
Thread	d mm	tpi	RH	L1	L	F	Y	h min	mm	Toolholder
1/16"-27NPT	6.0	27	6.0SIR27NPT...	16	50	2.50	1.00	0.66	5.9	SMC...-6.0
1/4"-18NPT		18	6.0SIR18NPT...	16	50	2.50	0.80	1.01	6.0	

Left handed tool supplied by request (Example: 6.0SIL18NPT...).

Micro - Single Ended
microscope

	Insert Dia.	Pitch	Ordering Code	Dimensions mm							Min. Bore Dia.		
Thread	d mm	tpi	RH/LH	Helix°	L1	F	Y	h min	L2 ref*	L ref	D mm	Toolholder	
1/16"-27NPT	6.0	27	M659TH27NPTL16R/L...	3.5	16	2.9	1.0	0.75	0.66	18.5	42.2	6.1	MH...-6.0
1/4"-18NPT		18	M659TH18NPTL16R/L...					1.0	1.01			10.7	
1/2"-14NPT		14	M659TH14NPTL16R/L...					1.05	1.33			17.0	

* L2 Ref: Repeatability within +/-0.02.

ANPT

External / Internal

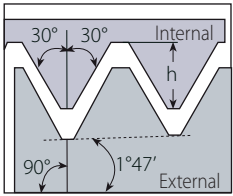

Defined by: MIL-P-7105B
Tolerance class: Standard ANPT

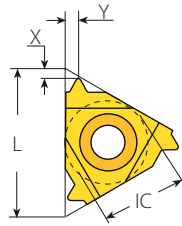

External Standard

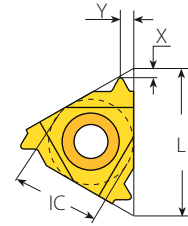

Internal Standard

Standard - External



Insert Size		Pitch	Ordering Code		Dimensions mm			Anvil		Toolholder
IC	L mm	tpi	RH	LH	h min	X	Y	RH	LH	
3/8"	16	18	3ER18ANPT...	3EL18ANPT...	1.08	0.8	1.0	YE3	YI3	AL..-3 (LH)
		14	3ER14ANPT...	3EL14ANPT...	1.39	0.8	1.0			

Standard - Internal



Insert Size		Pitch	Ordering Code		Dimensions mm			Anvil		Toolholder
IC	L mm	tpi	RH	LH	h min	X	Y	RH	LH	
1/4"	11	18	2IR18ANPT...	2IL18ANPT...	1.08	0.80	1.0	-	-	NVR..-2 (LH)
3/8"	16	14	3IR14ANPT...	3IL14ANPT...	1.39	0.80	1.0	YI3	YE3	AVR..-3 (LH)

NPTF

External

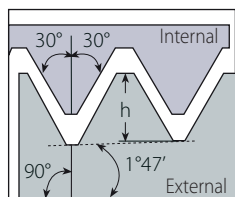

Defined by: ANSI B1.20.3-1976
Tolerance class: Class 2

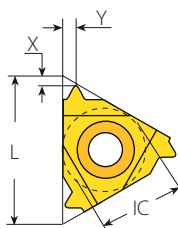

Standard

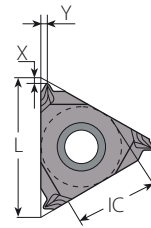

SCB
Sintered
Chipbreaker

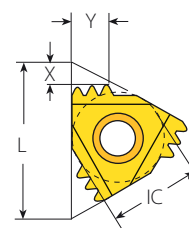

M+ Style

Standard



SCB

Insert Size		Pitch	Ordering Code		Dimensions mm			Anvil		Toolholder
IC	L mm	tpi	RH	LH	h min	X	Y	RH	LH	
1/4"	11	27	2ER27NPTF...	2EL27NPTF...	0.64	0.7	0.8	-	-	NL...-2 (LH)
		18	2ER18NPTF...	2EL18NPTF...	1.00	0.8	1.0	-	-	
		14	2ER14NPTF...	2EL14NPTF...	1.35	0.8	1.0	-	-	
3/8"	16	27	3ER27NPTF...	3EL27NPTF...	0.64	0.7	0.8	YE3	YI3	AL...-3 (LH)
		18	3ER18NPTF...	3EL18NPTF...	1.00	0.8	1.0			
		14	3ER14NPTF...	3EL14NPTF...	1.35	0.9	1.2			
		11.5	3ER11.5NPTF...	3EL11.5NPTF...	1.63	1.1	1.5			
3/8" SCB	16	27	3JER27NPTF...		0.64	0.7	0.8	YE3	-	AL...-3
		18	3JER18NPTF...		1.00	0.6	0.8			
		14	3JER14NPTF...		1.35	1.1	1.5			
		11.5	3JER11.5NPTF...		1.63	1.1	1.5			
		8	3JER8NPTF...		2.38	1.3	1.8			

M+ Style



Insert Size		Pitch	Teeth	Ordering Code	Dimensions mm			Anvil		Toolholder
IC	L mm	tpi		RH	h min	X	Y	RH		
3/8"	16	14	2	3ER14NPTF2M+...	1.35	2.0	3.0	YE3M	AL...-3	

NPTF (con't)

Internal

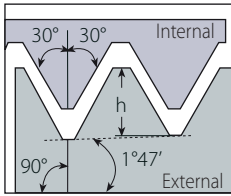

Defined by: ANSI B1.20.3-1976
Tolerance class: Class 2

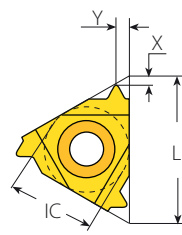

Standard

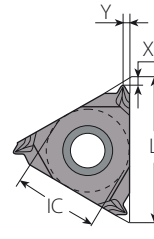

SCB
Sintered
Chipbreaker

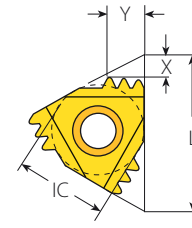

M+ Style

Standard



Insert Size		Pitch	Ordering Code		Dimensions mm			Anvil		Toolholder
IC	L mm	tpi	RH	LH	h min	X	Y	RH	LH	
1/4"	11	27	2IR27NPTF...	2IL27NPTF...	0.64	0.7	0.8	-	-	NVR..-2 (LH)
		18	2IR18NPTF...	2IL18NPTF...	1.00	0.8	1.0			
		14	2IR14NPTF...	2IL14NPTF...	1.35	0.8	1.0			
1/4" SCB	11	27	2JIR27NPTF...		0.64	0.7	0.8	-	-	NVR..-2
		18	2JIR18NPTF...		1.00	0.6	0.8			
3/8"	16	27	3IR27NPTF...	3IL27NPTF...	0.64	0.7	0.8	YI3	YE3	AVR..-3 (LH)
		18	3IR18NPTF...	3IL18NPTF...	1.00	0.8	1.0			
		14	3IR14NPTF...	3IL14NPTF...	1.35	0.9	1.2			
		11.5	3IR11.5NPTF...	3IL11.5NPTF...	1.63	1.1	1.5			
3/8" SCB	16	8	3IR8NPTF...	3IL8NPTF...	2.38	1.3	1.8	YI3	-	AVR..-3
		27	3JIR27NPTF...		0.64	0.7	0.8			
		18	3JIR18NPTF...		1.00	0.6	0.8			
		14	3JIR14NPTF...		1.35	1.1	1.5			
		11.5	3JIR11.5NPTF...		1.63	1.1	1.5			



SCB

M+ Style



Insert Size		Pitch	Teeth	Ordering Code	Dimensions mm			Anvil		Toolholder
IC	L mm	tpi		RH	h min	X	Y	RH		
3/8"	16	14	2	3IR14NPTF2M+...	1.35	2.0	3.0	YI3M	AVR..-3	

NPTF (con't)

Mini-V

Internal

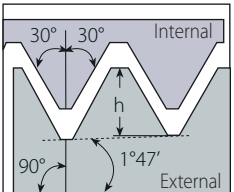

Defined by: ANSI 1.2.3-1976
Tolerance class: Standard NPTF

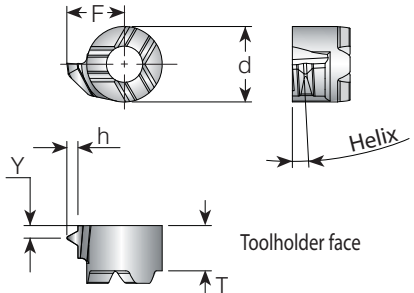

Mini-V



Min. Thread	Insert Style	Pitch	Ordering Code	Dimensions mm				Helix	Toolholder	
				T	F	Y	h min			
1/4"-18NPTF	V08	18	V08TH18NPTFR...	6	3.8	4.64	0.9	1.0	2.0	.V08-...

NPTF (con't)



Internal

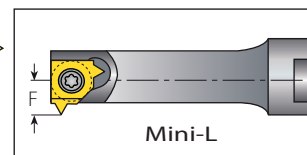
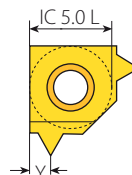
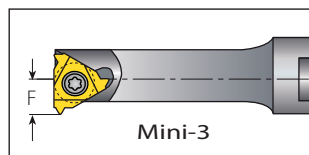
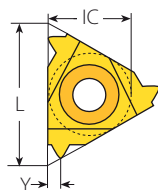
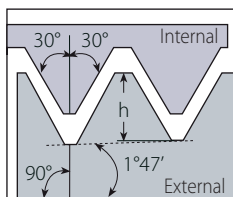

Defined by: ANSI B1.20.3-1976
Tolerance class: Class 2

Mini-3 Standard



Insert Size		Pitch	Ordering Code		Dimensions mm			Min. Bore Dia.	Toolholder
IC mm	L mm	tpi	RH	LH	h min	Y	F	mm	
4.0	6	27	4.0KIR27NPTF...	4.0KIL27NPTF...	0.64	0.6	3.6	6.25	.NVR.5-4.0K (LH)
5.0	8	27	5.0KIR27NPTF...	5.0KIL27NPTF...	0.64	0.6	4.7	7.8	.NVR.7-5.0K (LH)
		18	5.0KIR18NPTF...	5.0KIL18NPTF...	1.00	0.8			
6.0	10	27	6.0IR27NPTF...		0.64	0.8	5.3	10.0	.NVR1.-6.0
		18	6.0IR18NPTF...		1.00	1.0	5.3		
		14	6.0IR14NPTF...		1.35	1.1	5.3		

Left handed tool supplied by request (Example: 6.0IL27NPTF...).

Mini-L



Insert Size		Pitch	Ordering Code		Dimensions mm			Min. Bore Dia.	Toolholder
IC mm		tpi	RH	LH	h min	Y	F	mm	
5.0L		27	5LIR27NPTF...		0.64	0.8	4.65	8.0	.NVR 10-5L
		18	5LIR18NPTF...		1.00	1.0	4.65		
		14	5LIR14NPTF...		1.35	1.1	4.65		

Left handed tool supplied by request (Example: 5LIL27NPTF...).

NPTF

Internal

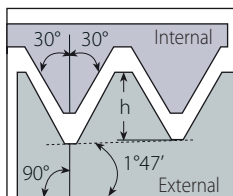

Defined by: ANSI B1.20.3-1976
Tolerance class: Class 2

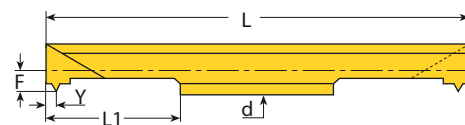

RH-Double Ended

Micro - Double Ended

Insert Dia.		Pitch	Ordering Code		Dimensions mm					Min. Bore Dia.	Toolholder
Thread	d mm	tpi	RH	L1	L	F	Y	h min	mm		
1/16"-27NPTF	6.0	27	6.0SIR27NPTF...	16	50	2.50	0.80	0.64	6.0	SMC.-6.0	
1/4"-18NPTF		18	6.0SIR18NPTF...	16	50	2.50	1.00	1.00			

Left handed tool supplied by request (Example: 6.0SIL18NPTF...).

NPS

External / Internal

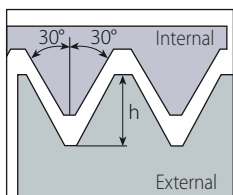

Defined by: USA NBS H28 (1957)
Tolerance class: Standard NPS

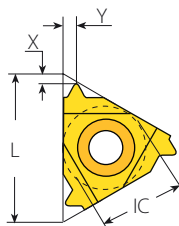

External Standard

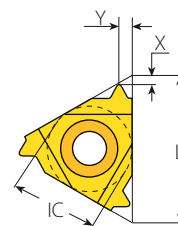

Internal Standard

Standard - External



Insert Size		Pitch	Ordering Code		Dimensions mm			Anvil		Toolholder
IC	L mm	tpi	RH	LH	h min	X	Y	RH	LH	
3/8"	16	24	3ER24NPS...	3EL24NPS...	0.79	0.7	0.8	YE3	YI3	AL...-3 (LH)
		16	3ER16NPS...	3EL16NPS...	1.21	0.8	1.1			
		14	3ER14NPS...	3EL14NPS...	1.33	0.9	1.2			
		12	3ER12NPS...	3EL12NPS...	1.63	1.1	1.4			
		11.5	3ER11.5NPS...	3EL11.5NPS...	1.71	1.1	1.5			
1/2"	22	9	3ER9NPS...	3EL9NPS...	2.20	1.2	1.6	YE4	YI4	AL...-4 (LH)
		8	4ER8NPS...	4EL8NPS...	2.46	1.3	1.9			
		7	4ER7NPS...	4EL7NPS...	2.82	1.6	2.3			
5/8"	27	6	4ER6NPS...	4EL6NPS...	3.31	1.6	2.3	YE5	YI5	AL...-5 (LH)
		5	5ER5NPS...	5EL5NPS...	3.98	1.9	2.8			

Standard - Internal



Insert Size		Pitch	Ordering Code		Dimensions mm			Anvil		Toolholder
IC	L mm	tpi	RH	LH	h min	X	Y	RH	LH	
3/8"	16	24	3IR24NPS...	3IL24NPS...	0.79	0.7	0.8	YI3	YE3	AVR...-3 (LH)
		14	3IR14NPS...	3IL14NPS...	1.33	0.9	1.2			
		12	3IR12NPS...	3IL12NPS...	1.63	1.1	1.4			
		11.5	3IR11.5NPS...	3IL11.5NPS...	1.71	1.1	1.5			
1/2"	22	9	3IR9NPS...	3IL9NPS...	2.20	1.2	1.6	YI4	YE4	AVR...-4 (LH)
		8	4IR8NPS...	4IL8NPS...	2.46	1.3	1.9			
		7	4IR7NPS...	4IL7NPS...	2.82	1.6	2.3			
5/8"	27	6	4IR6NPS...	4IL6NPS...	3.31	1.6	2.3	YI5	YE5	AVR...-5 (LH)
		5	5IR5NPS...	5IL5NPS...	3.98	1.9	2.8			

Round (DIN 405)

External

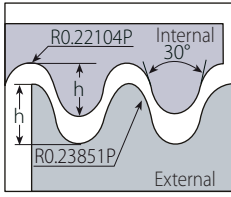

Defined by: DIN 405
Tolerance class: 7h/7H

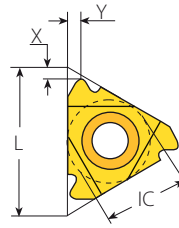

Standard

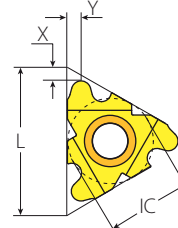

F-Line

Standard



F.LINE

Insert Size		Pitch	Ordering Code		Dimensions mm			Anvil		Toolholder
IC	L mm	tpi	RH	LH	h min	X	Y	RH	LH	
3/8"	16	10	3ER10RD...	3EL10RD...	1.27	1.1	1.2	YE3	YI3	AL..-3 (LH)
		8	3ER8RD...	3EL8RD...	1.59	1.4	1.3			
		6	3ER6RD...	3EL6RD...	2.12	1.5	1.7			
1/2"	22	6	4ER6RD...	4EL6RD...	2.12	1.5	1.7	YE4	YI4	AL..-4 (LH)
		4	4ER4RD...	4EL4RD...	3.18	2.2	2.3			
1/2"F	23	6	4FER6RD...		2.12	1.5	1.7	YE4F		AL...-4F
		4	4FER4RD...		3.18	2.2	2.3			
5/8"	27	4	5ER4RD...	5EL4RD...	3.18	2.2	2.3	YE5	YI5	AL..-5 (LH)

Internal

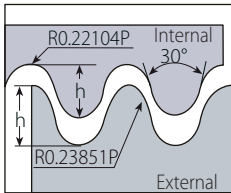

Defined by: DIN 405
Tolerance class: 7h/7H

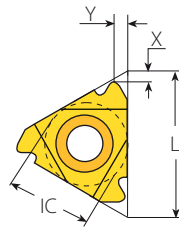

Standard

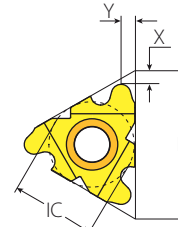

F-Line

Standard



F.LINE

Insert Size		Pitch	Ordering Code		Dimensions mm			Anvil		Toolholder
IC	L mm	tpi	RH	LH	h min	X	Y	RH	LH	
3/8"	16	10	3IR10RD...	3IL10RD...	1.27	1.1	1.2	YI3	YE3	AVR..-3 (LH)
		8	3IR8RD...	3IL8RD...	1.59	1.4	1.4			
		6	3IR6RD...	3IL6RD...	2.12	1.4	1.5			
1/2"	22	6	4IR6RD...	4IL6RD...	2.12	1.5	1.7	YI4	YE4	AVR..-4 (LH)
		4	4IR4RD...	4IL4RD...	3.18	2.2	2.3			
1/2"F	23	6	4FIR6RD...		2.12	1.5	1.7	YI4F		AVRC...-4F
		4	4FIR4RD...		3.18	2.2	2.3			
5/8"	27	4	5IR4RD...	5IL4RD...	3.18	2.2	2.3	YI5	YE5	AVR..-5 (LH)

Round (DIN 20400)

External

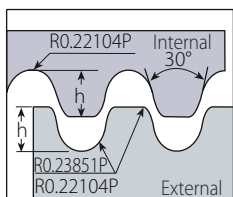

Defined by: DIN 20400
Tolerance class: Standard

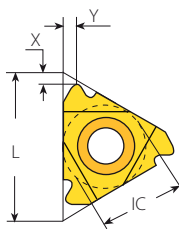

Standard

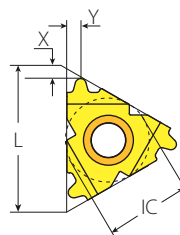

F-Line

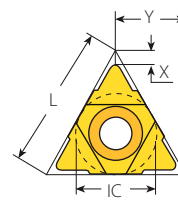

U Style

Standard



FLINE

Insert Size		Pitch	Ordering Code		Dimensions mm			Anvil		Toolholder
IC	L mm	mm	RH	LH	h min	X	Y	RH	LH	
1/2"	22	3.0	4ER3.0RD20400...	4EL3.0RD20400...	1.65	1.3	1.7	YE4	YI4	AL...-4 (LH)
		4.0	4ER4.0RD20400...	4EL4.0RD20400...	2.20	1.6	2.2			
		5.0	4ER5.0RD20400...	4EL5.0RD20400...	2.75	1.4	1.7			
		6.0	4ER6.0RD20400...	4EL6.0RD20400...	3.30	1.7	2.1			
1/2"F	23	3.0	4FER3.0RD20400...		1.65	1.3	1.7	YE4F		AL...-4F
		4.0	4FER4.0RD20400...		2.2	1.6	2.2			
		5.0	4FER5.0RD20400...		2.75	1.4	1.7			
		6.0	4FER6.0RD20400...		3.3	1.7	2.1			

U Style



Insert Size		Pitch	Ordering Code	Dimensions mm			Anvil		Toolholder	
IC	L mm	mm	RH+LH	h min	X	Y	RH	LH		
5/8"U	27	8.0	5UEI8.0RD20400...		4.4	2.9	13.5	YE5U	YI5U	AL...-5U (LH)

Round (DIN 20400) (con't)

MEGALINE

External

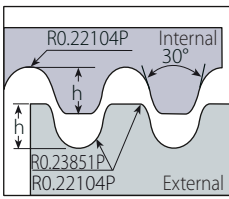

Defined by: DIN 20400
Tolerance class: Standard

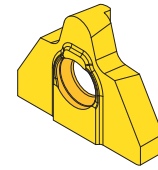
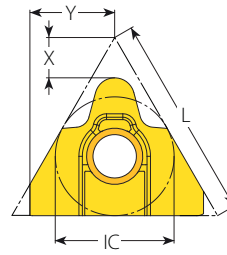

Mega Line

External



Insert Size	Pitch	Ordering Code	Dimensions mm			Number of Passes				
			IC	L mm	mm	RH	h min	X	Y	0.07mm-Min. Depth of Cut (On radius)
5/8" MG	10.0	5MGER10.0RD20400...				5.50	4.12		78	36
	12.0	5MGER12.0RD20400...				6.60	5.39	11.3	93	43
	16.0	5MGER16.0RD20400...				8.80	4.92		124	58

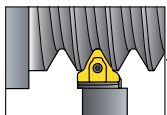

External Toolholders for Round (DIN 20400)

MEGALINE

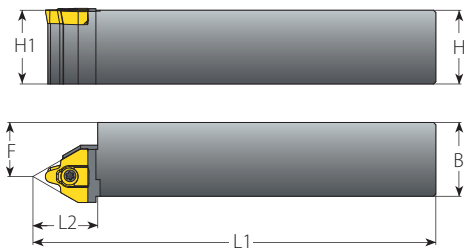
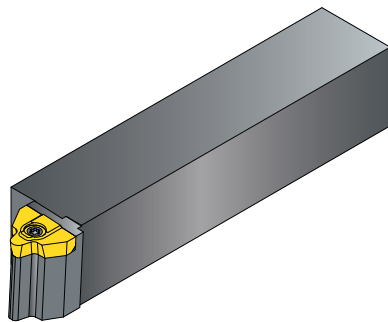

External

Spare Parts

Insert	Ordering Code	Dimensions mm				Thread Diameter Range (Min.-Max.)	Insert Screw	Torx Key
		RH	H=B=H1	F	L1			
5MGER10.0RD20400...	NL25-5MG10RD		25	16.5	155	(RD132-170)x10	S5MG	K6T
	NL32-5MG10RD		32	23.5	175			
	NL40-5MG10RD		40	31.5	205			
5MGER12.0RD20400...	NL25-5MG12RD		25	16.5	155	(RD180-224)x12		
	NL32-5MG12RD		32	23.5	175			
	NL40-5MG12RD		40	31.5	205			
5MGER16.0RD20400...	NL25-5MG16RD		25	16.5	155	(RD236-300)x16		
	NL32-5MG16RD		32	23.5	175			
	NL40-5MG16RD		40	31.5	205			

Recommended thread infeed method for Mega Line: Flank or Modified Flank 1°.

Round (DIN 20400) (con't)

Internal

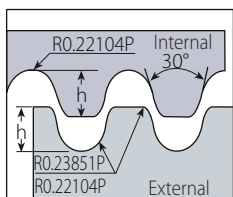

Defined by: DIN 20400
Tolerance class: Standard

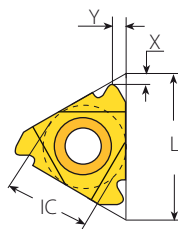

Standard

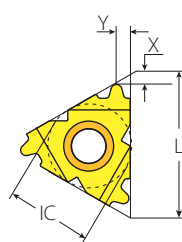

F-Line

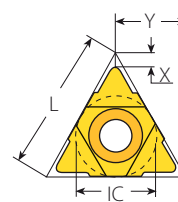

U Style

Standard



FLINE

Insert Size		Pitch	Ordering Code		Dimensions mm			Anvil		Toolholder
IC	L mm	mm	RH	LH	h min	X	Y	RH	LH	
1/2"	22	3.0	4IR3.0RD20400...	4IL3.0RD20400...	1.65	1.3	1.7	Y14	YE4	AVR...-4 (LH)
		4.0	4IR4.0RD20400...	4IL4.0RD20400...	2.20	1.6	2.2			
		5.0	4IR5.0RD20400...	4IL5.0RD20400...	2.75	1.4	1.7			
		6.0	4IR6.0RD20400...	4IL6.0RD20400...	3.30	1.7	2.1			
1/2"F	23	3.0	4FIR3.0RD20400...		1.65	1.3	1.7	Y14F		AVRC...-4F
		4.0	4FIR4.0RD20400...		2.2	1.6	2.2			
		5.0	4FIR5.0RD20400...		2.75	1.4	1.7			
		6.0	4FIR6.0RD20400...		3.3	1.7	2.1			

U Style



Insert Size		Pitch	Ordering Code	Dimensions mm			Anvil		Toolholder	
IC	L mm	mm	RH+LH	h min	X	Y	RH	LH		
5/8"U	27	8.0	5UEI8.0RD20400...		4.4	2.9	13.5	YI5U	YESU	AVR...-5U (LH)

Round (DIN 20400) (con't)

MEGALINE

Internal

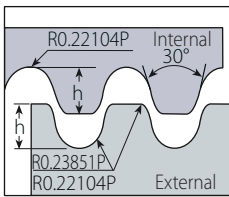

Defined by: DIN 20400
Tolerance class: Standard

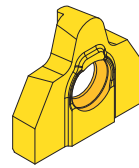

Mega Line

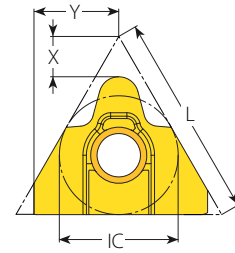

Internal



Insert Size	Pitch		Ordering Code	Dimensions mm			Number of Passes	
	IC	L mm		mm	RH	h min	X	Y
5/8" MG	27	10.0	5MGIR10.0RD20400...	5.50	4.12	10.4	78	36
		12.0	5MGIR12.0RD20400...	6.60	5.39		93	43
		16.0	5MGIR16.0RD20400...	8.80	4.92		124	58

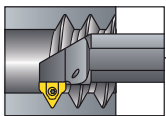

Internal Toolholders for Round (DIN 20400)

MEGALINE

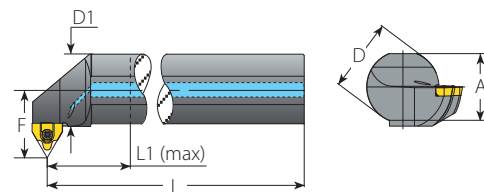
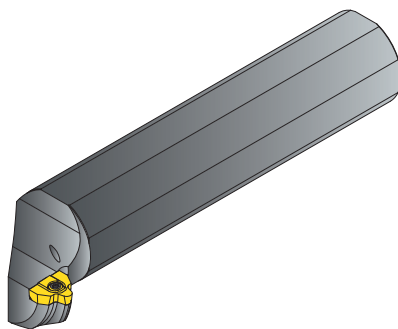

Internal

Insert	Ordering Code	Dimensions mm						Min. Bore Dia.	Thread Diameter Range (Min.-Max.)		Spare Parts	
		RH	A	L	L1 (max)	D	D1		F	mm	Short Chip Material	Long Chip Material
5MGIR10.0RD20400...	NVRC40-5MG10RD	36	232.5	100	40	39.7	41.5	122	(RD132-170)x10	(RD132-170)x10	S5MG	K6T
	NVRC50-5MG10RD	46	257.5	125	50	49.7	46.5					
	NVRC60-5MG10RD	57	282.5	150	60	59.7	51.5					
5MGIR12.0RD20400...	NVRC40-5MG12RD	36	232.5	100	40	39.7	41.5	168	(RD180-224)x12	(RD180-224)x12		
	NVRC50-5MG12RD	46	257.5	125	50	49.7	46.5					
	NVRC60-5MG12RD	57	282.5	150	60	59.7	51.5					
5MGIR16.0RD20400...	NVRC40-5MG16RD	36	232.5	100	40	39.7	41.5	220	(RD236-300)x16	(RD236-300)x16		
	NVRC50-5MG16RD	46	257.5	125	50	49.7	46.5					
	NVRC60-5MG16RD	57	282.5	150	60	59.7	51.5					

Recommended thread infeed method for Mega Line: Flank or Modified Flank 1°.

Trapez

External

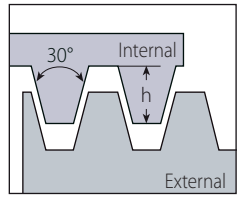

Defined by: DIN 103
Tolerance class: 7e/7H

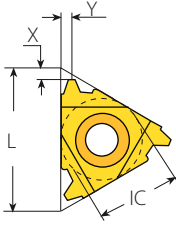

Standard

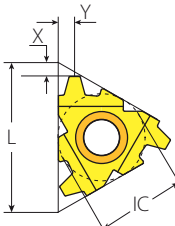

F-Line

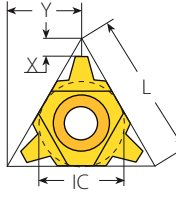

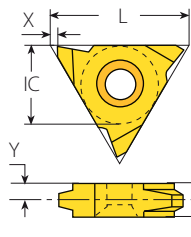

U Style



V Style

Standard

Insert Size		Pitch	Ordering Code		Dimensions mm			Anvil		
IC	L mm	mm	RH	LH	h min	X	Y	RH	LH	Toolholder
1/4"	11	1.5	2ER1.5TR...	2EL1.5TR...	0.90	0.8	0.9	-	-	NL...-2 (LH)
		1.5	3ER1.5TR...	3EL1.5TR...	0.90	1.0	1.1			
3/8"	16	2.0	3ER2.0TR...	3EL2.0TR...	1.25	1.1	1.3	YE3	YI3	AL...-3 (LH)
		2.5	3ER2.5TR...	3EL2.5TR...	1.55	1.2	1.4			
		3.0	3ER3.0TR...	3EL3.0TR...	1.75	1.3	1.5			
1/2"	22	4.0	4ER4.0TR...	4EL4.0TR...	2.25	1.7	1.9	YE4	YI4	AL...-4 (LH)
		5.0	4ER5.0TR...	4EL5.0TR...	2.75	2.1	2.5			
		6.0	4ER6.0TR...	4EL6.0TR...	3.50	2.3	2.7			
1/2"F	23	4.0	4FER4.0TR...		2.25	1.7	1.9	YE4F		AL...-4F
		5.0	4FER5.0TR...		2.75	2.1	2.5			
		6.0	4FER6.0TR...		3.50	2.3	2.7			
5/8"	27	6.0	5ER6.0TR...	5EL6.0TR...	3.50	2.3	2.7	YE5	YI5	AL...-5 (LH)

U Style

Insert Size		Pitch	Ordering Code	Dimensions mm			Anvil		
IC	L mm	mm	RH+LH	h min	X	Y	RH	LH	Toolholder
1/2"U	22	6.0	4UE6.0TR...	3.50	2.0	11.0	YE4U	YI4U	AL...-4U (LH)
		7.0	4UE7.0TR...	4.00	2.3	11.0			
		8.0	4UE8.0TR...	4.50	2.6	11.0			
5/8"U	27	8.0	5UE8.0TR...	4.50	2.6	13.7	YE5U	YI5U	AL...-5U (LH)
		9.0	5UE9.0TR...	5.00	3.0	13.7			



V Style

Insert Size		Pitch	Ordering Code		Dimensions mm				
IC	L mm	mm	RH	LH	h min	X	Y	T	Toolholder
5/8"V	27	6.0	5VER6.0TR...	5VEL6.0TR...	3.50	1.0	3.3	6	NL...-5V-6 (LH)
		7.0	5VER7.0TR...	5VEL7.0TR...	4.00	1.0	3.3	6	
		8.0	5VER8.0TR...	5VEL8.0TR...	4.50	1.0	3.3	6	NL...-5V-8 (LH)
		9.0	5VER9.0TR...	5VEL9.0TR...	5.00	1.0	4.3	8	
		10.0	5VER10.0TR...	5VEL10.0TR...	5.50	1.0	4.3	8	
		12.0	5VER12.0TR...	5VEL12.0TR...	6.50	1.0	5.2	10	



Trapez (con't)

MEGALINE

External

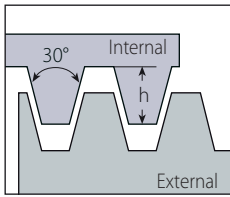

Defined by: DIN 103
Tolerance class: 7e/7H

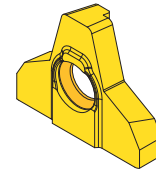
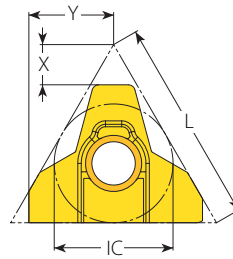

Mega Line

External





Insert Size		Pitch	Ordering Code	Dimensions mm			Number of Passes	
IC	L mm	mm	RH	h min	X	Y	0.07mm-Min. Depth of Cut (On radius)	0.15mm-Max. Depth of Cut (On radius)
5/8" MG	27	12.0	5MGER12.0TR...	6.5	5.38	11.3	94	44
		14.0	5MGER14.0TR...	8.0	4.38		115	54
		16.0	5MGER16.0TR...	9.0	5.38		129	60
		18.0	5MGER18.0TR...	10.0	5.38		143	67
		20.0	5MGER20.0TR...	11.0	7.38		158	74
		24.0	5MGER24.0TR...	13.0	7.38		186	87

Recommended thread infeed method for Mega Line: Flank or Modified Flank 1°.

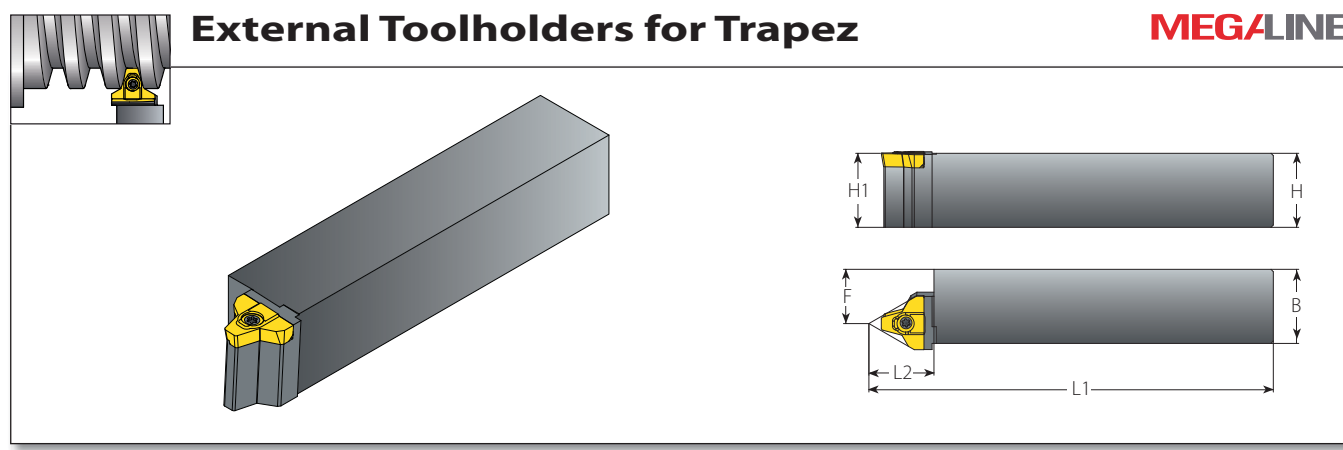
External Toolholders for Trapez



External							Spare Parts	
Insert	Ordering Code	Dimensions mm				Thread Diameter Range (Min.-Max.)		
		RH	H=B=H1	F	L1			
5MGER12.0TR...	NL25-5MG12TR	25	16.5	155	22	(TR44-300)x12	S5MG	K6T
	NL32-5MG12TR	32	23.5	175				
	NL40-5MG12TR	40	31.5	205				
5MGER14.0TR...	NL25-5MG14TR	25	16.5	155	22	(TR55-145)x14		
	NL32-5MG14TR	32	23.5	175				
	NL40-5MG14TR	40	31.5	205				
5MGER16.0TR...	NL25-5MG16TR	25	16.5	155	22	(TR65-175)x16		
	NL32-5MG16TR	32	23.5	175				
	NL40-5MG16TR	40	31.5	205				
5MGER18.0TR...	NL25-5MG18TR	25	16.5	155	22	(TR85-200)x18		
	NL32-5MG18TR	32	23.5	175				
	NL40-5MG18TR	40	31.5	205				
5MGER20.0TR...	NL25-5MG20TR	25	16.5	155	22	(TR100-230)x20		
	NL32-5MG20TR	32	23.5	175				
	NL40-5MG20TR	40	31.5	205				
5MGER24.0TR...	NL25-5MG24TR	25	16.5	155	22	(TR135-300)x24		
	NL32-5MG24TR	32	23.5	175				
	NL40-5MG24TR	40	31.5	205				

Recommended thread infeed method for Mega Line: Flank or Modified Flank 1°.

Trapez (con't)

Internal

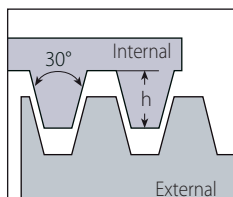

Defined by: DIN 103
Tolerance class: 7e/7H

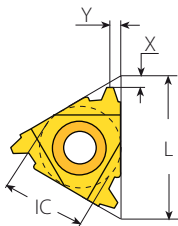

Standard

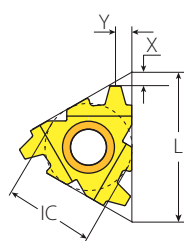

F-Line

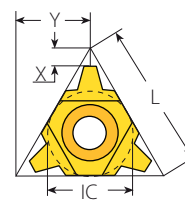

U Style

Standard

Insert Size		Pitch	Ordering Code		Dimensions mm			Anvil		Toolholder
IC	L mm	mm	RH	LH	h min	X	Y	RH	LH	
1/4"	11	1.5	2IR1.5TR...	2IL1.5TR...	0.90	0.8	0.9	-	-	NVR 8-2 (LH)
		1.5	3IR1.5TR...	3IL1.5TR...	0.90	1.0	1.1			
3/8"	16	2.0	3IR2.0TR...	3IL2.0TR...	1.25	1.1	1.3	YI3	YE3	AVR..-3 (LH)
		2.5	3IR2.5TR...	3IL2.5TR...	1.53	1.2	1.4			
		3.0	3IR3.0TR...	3IL3.0TR...	1.75	1.3	1.5			
1/2"	22	4.0	4IR4.0TR...	4IL4.0TR...	2.25	1.7	1.9	YI4	YE4	AVR..-4 (LH)
		5.0	4IR5.0TR...	4IL5.0TR...	2.75	2.1	2.5			
		6.0	4IR6.0TR...	4IL6.0TR...	3.50	2.3	2.7			
1/2" F	23	4.0	4FIR4.0TR...		2.25	1.7	1.9	YI4F		AVRC...-4F
		5.0	4FIR5.0TR...		2.75	2.1	2.5			
5/8"	27	6.0	5IR6.0TR...	5IL6.0TR...	3.50	2.3	2.7	YI5	YE5	AVR..-5 (LH)
		6.0	4FIR6.0TR...		3.5	2.3	2.7			



FLINE

Trapez (con't)

Internal

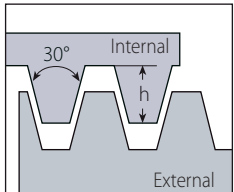

Defined by: DIN 103
Tolerance class: 7e/7H

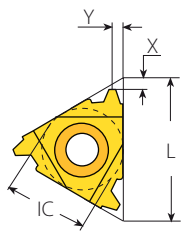

Coarse Pitch

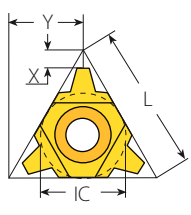

U Style Coarse Pitch

Coarse Pitch RH

	Thread	Insert Size		Ordering Code	Dimensions mm			Toolholder RH	Min Bore Dia.
		IC	L mm	RH	h min	X	Y		mm
	TR18x4	3/8"U	16	3UIR4.0TR...158/013	2.25	2.10	8.0	NVRC11-3U-156/020	14.0
	TR20x4	3/8"	16	3IR4.0TR...158/012	2.25	1.53	1.9	NVRC13-3-156/006	16.0
	TR22x5	3/8"U	16	3UIR5.0TR...158/011	2.75	1.56	8.0	NVRC14-3U-156/018	17.0
	TR24x5			3UIR5.0TR...158/011	2.75	1.56	8.0	NVRC15-3U-156/019	19.0
	TR26x5	1/2"	22	3UIR5.0TR...158/011	2.75	1.56	8.0	NVRC15-3U-156/019	21.0
	TR28x5			4IR5.0TR...	2.75	2.30	2.7	NVRC20-4-156/008	23.0
	TR30x6	1/2"U	22	4UIR6.0TR...158/007	3.50	1.94	11.0	NVRC20-4U-156/011	24.0
	TR36x6	5/8"	27	5IR6.0TR...	3.50	2.30	2.7	NVRC25-5-156/012	30.0
	TR38x7	1/2"U	22	4UIR7.0TR...158/008	4.00	2.27	11.0	NVRC25-4U-156/013	31.0
	TR40x7			4UIR7.0TR...158/008	4.00	2.27	11.0	NVRC25-4U-156/013	33.0
TR42x7	4UIR7.0TR...158/008			4.00	2.27	11.0	NVRC32-4U-156/014	35.0	
TR44x7	4UIR7.0TR...158/008			4.00	2.27	11.0	NVRC32-4U-156/014	37.0	
TR46x8	5/8"U	27	5UIR8.0TR...158/010	4.50	2.59	13.5	NVRC32-5U-156/015	38.0	
TR48x8			5UIR8.0TR...158/010	4.50	2.59	13.5	NVRC32-5U-156/015	40.0	
TR50x8			5UIR8.0TR...158/010	4.50	2.59	13.5	NVRC32-5U-156/015	42.0	
TR52x8			5UIR8.0TR...158/010	4.50	2.59	13.5	NVRC32-5U-156/015	44.0	

Coarse Pitch LH

	Thread	Insert Size		Ordering Code	Dimensions mm			Toolholder LH	Min Bore Dia.
		IC	L mm	LH	h min	X	Y		mm
	TR18x4	3/8"U	16	3UIR4.0TR...158/013	2.25	2.10	8.0	NVRC11-3ULH-156/029	14.0
	TR20x4	3/8"	16	3IL4.0TR...158/015	2.25	1.53	1.9	NVRC13-3LH-156/028	16.0
	TR22x5	3/8"U	16	3UIR5.0TR...158/011	2.75	1.56	8.0	NVRC14-3ULH-156/030	17.0
	TR24x5			3UIR5.0TR...158/011	2.75	1.56	8.0	NVRC15-3ULH-156/031	19.0
	TR26x5	1/2"	22	3UIR5.0TR...158/011	2.75	1.56	8.0	NVRC15-3ULH-156/031	21.0
	TR28x5			4IL5.0TR...	2.75	2.30	2.7	NVRC20-4LH-156/024	23.0
	TR30x6	1/2"U	22	4UIR6.0TR...158/007	3.50	1.94	11.0	NVRC20-4ULH-156/021	24.0
	TR36x6	5/8"	27	5IL6.0TR...	3.50	2.30	2.7	NVRC25-5LH-156/017	30.0
	TR38x7	1/2"U	22	4UIR7.0TR...158/008	4.00	2.27	11.0	NVRC25-4ULH-156/032	31.0
	TR40x7			4UIR7.0TR...158/008	4.00	2.27	11.0	NVRC25-4ULH-156/032	33.0
TR42x7	4UIR7.0TR...158/008			4.00	2.27	11.0	NVRC32-4ULH-156/022	35.0	
TR44x7	4UIR7.0TR...158/008			4.00	2.27	11.0	NVRC32-4ULH-156/022	37.0	
TR46x8	5/8"U	27	5UIR8.0TR...158/010	4.50	2.59	13.5	NVRC32-5ULH-156/027	38.0	
TR48x8			5UIR8.0TR...158/010	4.50	2.59	13.5	NVRC32-5ULH-156/027	40.0	
TR50x8			5UIR8.0TR...158/010	4.50	2.59	13.5	NVRC32-5ULH-156/027	42.0	
TR52x8			5UIR8.0TR...158/010	4.50	2.59	13.5	NVRC32-5ULH-156/027	44.0	

U Type RH inserts can be used for both LH and RH applications.

Trapez (con't)

Internal

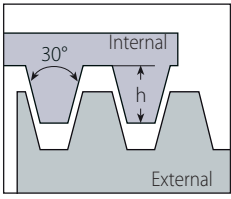

Defined by: DIN 103
Tolerance class: 7e/7H

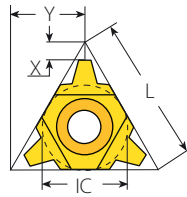

U Style

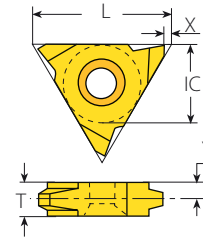

V Style

U Style



Insert Size	Pitch	Ordering Code	Dimensions mm			Anvil		Toolholder	
			IC	L mm	mm	RH	LH		
1/2"U	22	4UI6.0TR...	6.0	3.50	2.0	11.0	Y14U	YE4U	AVR...-4U (LH)
		4UI7.0TR...	7.0	4.00	2.3	11.0			
		4UI8.0TR...	8.0	4.50	2.6	11.0			
5/8"U	27	5UI8.0TR...	8.0	4.50	2.6	13.7	Y15U	YE5U	AVR...-5U (LH)
		5UI9.0TR...	9.0	5.00	3.0	13.7			

V Style



Insert Size	Pitch	Ordering Code	Dimensions mm						Toolholder
			IC	L mm	mm	RH	LH	h min	
5/8"V	27	5VIR6.0TR...	6.0	3.50	1.0	3.3	6	NVR...-5V (LH)	
		5VIR7.0TR...	7.0	4.00	1.0	3.3	6		
		5VIR8.0TR...	8.0	4.50	1.0	3.3	6		
		5VIR9.0TR...	9.0	5.00	1.0	4.3	8		
		5VIR10.0TR...	10.0	5.50	1.0	4.3	8		
		5VIR12.0TR...	12.0	6.50	1.0	5.2	10		

Trapez

MEGALINE

Internal

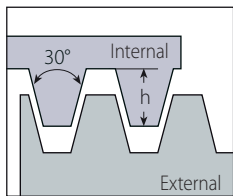

Defined by: DIN 103
Tolerance class: 7e/7H

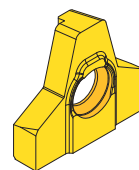

Mega Line

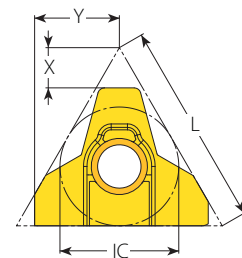

Internal



Insert Size	Pitch	Ordering Code	Dimensions mm			Number of Passes		
			IC	L mm	mm	RH	h min	X
5/8" MG	27	5MGIR12.0TR...	12.0	6.5	5.38	10.4	96	45
		5MGIR14.0TR...	14.0	8.0	4.38		118	55
		5MGIR16.0TR...	16.0	9.0	5.38		131	61
		5MGIR18.0TR...	18.0	10.0	5.38		145	68
		5MGIR20.0TR...	20.0	11.0	7.38		160	75
		5MGIR24.0TR...	24.0	13.0	7.38		188	88

Recommended thread infeed method for Mega Line: Flank or Modified Flank 1°.

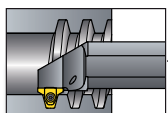

Internal Toolholders for Trapez

MEGA/LINE

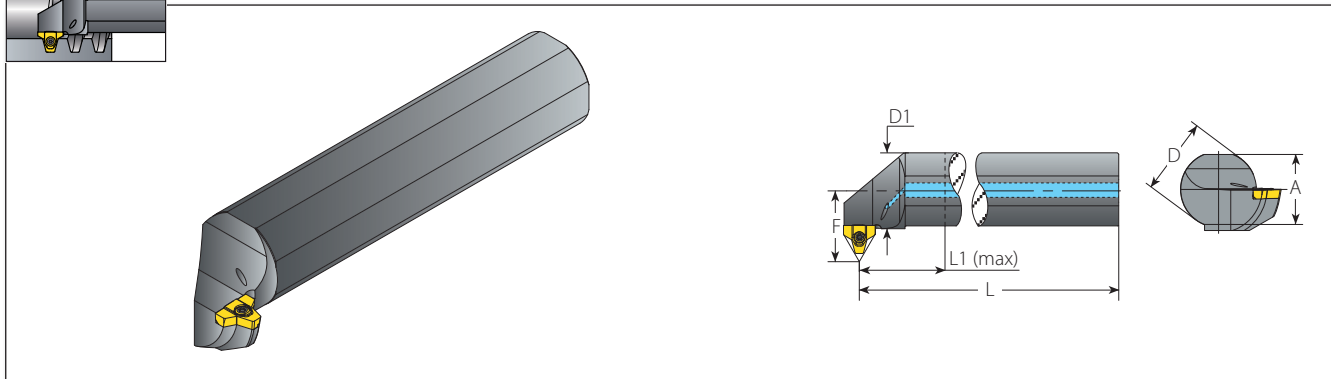

Internal

Spare Parts

Insert	Ordering Code	Dimensions mm							Min. Bore Dia. mm	Thread Diameter Range (Min.-Max.)		Spare Parts	
		RH	A	L	L1 (max)	D	D1	F		Short Chip Material	Long Chip Material	Insert Screw	Torx Key
5MGIR12.0TR...	NVRC40-5MG12TR	36	232.5	100	40	39.7	41.5	73	(TR85-300)x12	(TR85-300)x12	S5MG	K6T	
	NVRC50-5MG12TR	46	257.5	125	50	49.7	46.5	73	(TR85-300)x12	(TR95-300)x12			
	NVRC60-5MG12TR	57	282.5	150	60	59.7	51.5	83	(TR95-300)x12	(TR105-300)x12			
5MGIR14.0TR...	NVRC40-5MG14TR	36	232.5	100	40	39.7	41.5	101	(TR115-145)x14	(TR115-145)x14			
	NVRC50-5MG14TR	46	257.5	125	50	49.7	46.5	101	(TR115-145)x14	(TR115-145)x14			
	NVRC60-5MG14TR	57	282.5	150	60	59.7	51.5	101	(TR115-145)x14	(TR115-145)x14			
5MGIR16.0TR...	NVRC40-5MG16TR	36	232.5	100	40	39.7	41.5	64	(TR80-175)x16	(TR150-175)x16			
	NVRC50-5MG16TR	46	257.5	125	50	49.7	46.5	134	(TR150-175)x16	(TR150-175)x16			
	NVRC60-5MG16TR	57	282.5	150	60	59.7	51.5	134	(TR150-175)x16	(TR150-175)x16			
5MGIR18.0TR...	NVRC40-5MG18TR	36	232.5	100	40	39.7	41.5	72	(TR85-200)x18	(TR90-200)x18			
	NVRC50-5MG18TR	46	257.5	125	50	49.7	46.5	72	(TR90-200)x18	(TR180-200)x18			
	NVRC60-5MG18TR	57	282.5	150	60	59.7	51.5	162	(TR180-200)x18	(TR180-200)x18			
5MGIR20.0TR...	NVRC40-5MG20TR	36	232.5	100	40	39.7	41.5	80	(TR100-230)x20	(TR100-230)x20			
	NVRC50-5MG20TR	46	257.5	125	50	49.7	46.5	80	(TR100-230)x20	(TR100-230)x20			
	NVRC60-5MG20TR	57	282.5	150	60	59.7	51.5	85	(TR105-230)x20	(TR210-230)x20			
5MGIR24.0TR...	NVRC40-5MG24TR	36	232.5	100	40	39.7	41.5	111	(TR135-300)x24	(TR135-300)x24			
	NVRC50-5MG24TR	46	257.5	125	50	49.7	46.5	111	(TR135-300)x24	(TR135-300)x24			
	NVRC60-5MG24TR	57	282.5	150	60	59.7	51.5	111	(TR135-300)x24	(TR135-300)x24			

Recommended thread infeed method for Mega Line: Flank or Modified Flank 1°.

Trapez (con't)

Mini-V

Internal

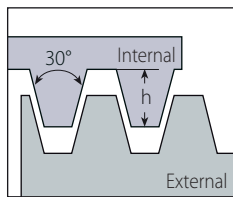

Defined by: DIN 103
Tolerance class: 7e/7H

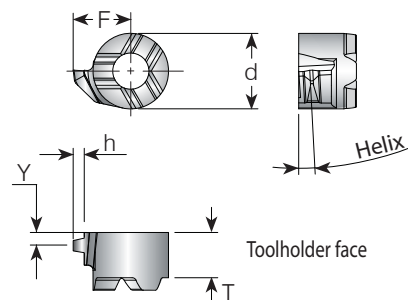

Mini-V



Min. Thread	Insert Style	Pitch mm	Ordering Code		Dimensions mm					Helix Deg.	Toolholder
			RH	d	T	F	Y	h min			
TR10x2.0	V08	2.0	V08TH2.0TRR...	6	3.8	4.79	0.9	1.25	3.5	.V08-...	
TR11x3.0		3.0	V08TH3.0TRR...	8	4.2	4.95	1.18	1.75	5		
TR16x4.0	V11	4.0	V11TH4.0TRR...	8	4.2	6.53	1.55	2.25	4.5	.V11-...	

Trapez

MINIPRO

Internal

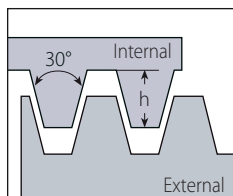

Defined by: DIN 103
Tolerance class: 7e/7H

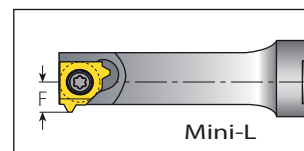
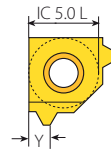
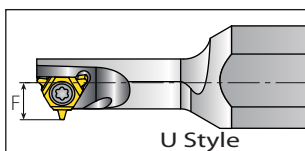
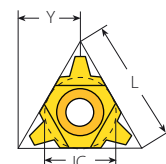
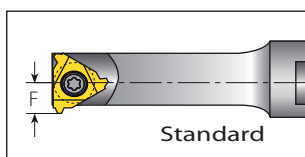
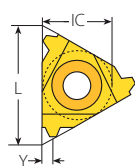

Mini-3 Standard



Insert Size		Pitch mm	Ordering Code		Dimensions mm			Min. Bore Dia. mm	Toolholder
IC mm	L mm		RH	LH	h min	Y	F		
5.0	8	1.5	5.0KIR1.5TR...	5.0KIL1.5TR...	0.85	0.7	4.7	7.8	.NVRC 7-5.0K (LH)
6.0	10	1.5	6.0IR1.5TR...		0.85	0.85	5.3	10.0	.NVR1...-6.0
		2.0	6.0IR2.0TR...		1.25	1.30	5.3	10.0	

Left handed tool supplied by request (Example: 6.0IL1.5TR...).

Mini-3 U Style



Insert Size		Pitch mm	Ordering Code		Dimensions mm			Min. Bore Dia. mm	Toolholder
IC mm	L mm		RH+LH		h min	Y	F		
5.0U	8	2.0	5.0KUI2TR...		1.25	4.0	5.7	9.0	.NVRC 8-5.0KU (LH)

Mini-L



Insert Size		Pitch mm	Ordering Code		Dimensions mm			Min. Bore Dia. mm	Toolholder
IC mm			RH	LH	h min	Y	F		
5.0L		1.5	5LIR1.5TR...		0.85	0.85	4.65	8.0	.NVR 10. -5L
		2.0	5LIR2.0TR...		1.25	1.30	4.80	9.0	

Left handed tool supplied by request (Example: 5LIL1.5TR...).

American ACME

External

Defined by: ANSI B1.5:1988
Tolerance class: 3G

Standard

F-Line

U Style

V Style

On Edge

Standard

	Insert Size		Pitch	Ordering Code		Dimensions mm			Anvil		Toolholder
	IC	L mm	tpi	RH	LH	h min	X	Y	RH	LH	
	1/4"	11	16	2ER16ACME...	2EL16ACME...	0.92	1.0	1.1	-	-	NL..-2 (LH)
			14	3ER14ACME...	3EL14ACME...	1.03	1.0	1.2			
	3/8"	16	12	3ER12ACME...	3EL12ACME...	1.19	1.1	1.2	YE3	YI3	AL..-3 (LH)
			10	3ER10ACME...	3EL10ACME...	1.52	1.3	1.4			
			8	3ER8ACME...	3EL8ACME...	1.84	1.4	1.5			
			7	3ER7ACME...	3EL7ACME...	2.08	1.9	2.2			
			6	3ER6ACME...	3EL6ACME...	2.37	1.7	1.9			
1/2"	22	7	4ER7ACME...	4EL7ACME...	2.08	1.9	2.2	YE4	YI4	AL..-4 (LH)	
		6	4ER6ACME...	4EL6ACME...	2.37	1.8	2.1				
		5	4ER5ACME...	4EL5ACME...	2.79	2.0	2.3				
1/2" F	23	6	4FER6ACME...		2.37	1.8	2.1	YE4F		AL...-4F	
		5	4FER5ACME...		2.79	2	2.3				
5/8"	27	4	5ER4ACME...	5EL4ACME...	3.43	2.4	2.7	YE5	YI5	AL..-5 (LH)	

U Style

	Insert Size		Pitch	Ordering Code		Dimensions mm			Anvil		Toolholder
	IC	L mm	tpi	RH+LH	h min	X	Y	RH	LH		
	1/2" U	22	4	4UE4ACME...	3.43	2.3	11.0	YE4U	YI4U	AL..-4U (LH)	
			3	4UE3ACME...	4.49	3.0	11.0				
5/8" U	27	3	5UE3ACME...	4.49	3.0	13.7	YE5U	YI5U	AL..-5U (LH)		

V Style

	Insert Size		Pitch	Ordering Code		Dimensions mm				Toolholder
	IC	L mm	tpi	RH	LH	h min	X	Y	T	
	5/8" V	27	4	5VER4ACME...	5VEL4ACME...	3.43	1.0	3.3	6	NL..-5V-6 (LH)
			3.5	5VER3.5ACME...	5VEL3.5ACME...	3.85	1.0	3.3	6	
			3	5VER3ACME...	5VEL3ACME...	4.49	1.0	3.3	6	
			2	5VER2ACME...	5VEL2ACME...	6.60	1.0	5.2	10	

On Edge

	Insert Size		Pitch	Ordering Code		Dimensions mm			
	IC	L mm	tpi	RH	h min	T	Ø C	X	Y
	1/2"	22	12	TNEC43E112ACME...	1.19	4.76	5.2	0.5	2.4
			10	TNEC43E110ACME...	1.52				
			8	TNEC43E108ACME...	1.83				
			6	TNEC43E106ACME...	2.36				
			4	TNEC43E104ACME...	3.43				
5/8"	27	4	TNEC54E104ACME...	3.43	6.35	6.5		3.2	
		3	TNEC54E103ACME...	4.50					
3/4"	32	2	TNEC56E102ACME...	6.60	9.53	8.0		4.8	

On Edge inserts are suited to existing toolholders on the market.

American ACME (con't)

MEGALINE

External

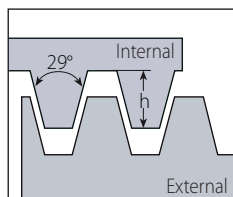

Defined by: ANSI B1.5:1988
Tolerance class: 3G

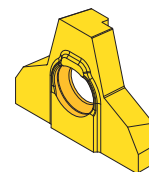
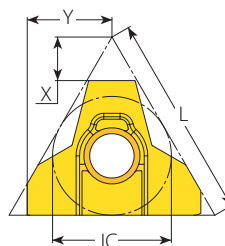

Mega Line

External



Insert Size		Pitch	Ordering Code	Dimensions mm			Number of Passes	
IC	L mm	tpi	RH	h min	X	Y	0.07mm-Min. Depth of Cut (On radius)	0.15mm-Max. Depth of Cut (On radius)
5/8" MG	27	2	5MGER2ACME...	6.60	4.81	11.3	95	44
		1 1/2	5MGER1-1/2ACME...	8.72	5.81		125	58
		1 1/3	5MGER1-1/3ACME...	9.78	6.81		140	65
		1	5MGER1ACME...	12.95	8.31		186	87

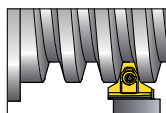

External Toolholders for American ACME

MEGALINE

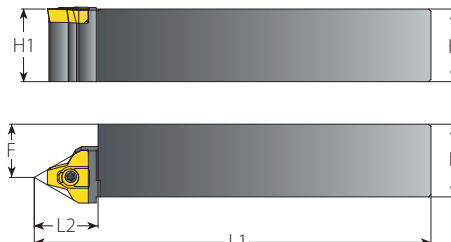
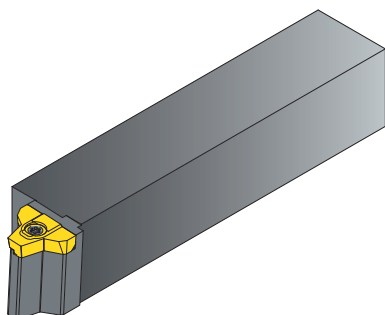

External

Insert	Ordering Code	Dimensions				Thread Diameter Range (Min.-Max.)	Spare Parts	
		RH	H=B=H1	F	L1		L2	Insert Screw
5MGER2ACME...	NL25-5MG2ACME		25	16.5	155	(3"-5")-2ACME	S5MG	K6T
	NL32-5MG2ACME		32	23.5	175			
	NL40-5MG2ACME		40	31.5	205			
5MGER1-1/2ACME...	NL25-5MG1-1/2ACME		25	16.5	155	(3"-5")-1 1/2ACME		
	NL32-5MG1-1/2ACME		32	23.5	175			
	NL40-5MG1-1/2ACME		40	31.5	205			
5MGER1-1/3ACME...	NL25-5MG1-1/3ACME		25	16.5	155	(3"-5")-1 1/3ACME		
	NL32-5MG1-1/3ACME		32	23.5	175			
	NL40-5MG1-1/3ACME		40	31.5	205			
5MGER1ACME...	NL25-5MG1ACME		25	16.5	155	(3.5"-5")-1ACME		
	NL32-5MG1ACME		32	23.5	175			
	NL40-5MG1ACME		40	31.5	205			

Recommended thread infeed method for Mega Line: Flank or Modified Flank 1°.

American ACME (con't)

Internal

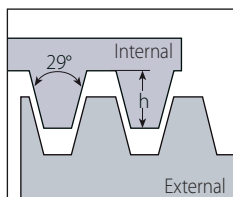

Defined by: ANSI B1.5:1988
Tolerance class: 3G

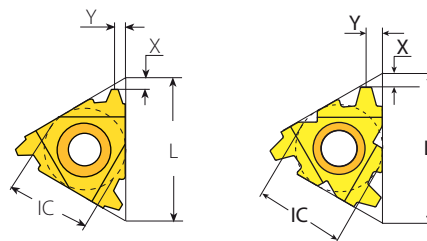

Standard

F-Line

Standard

Insert Size		Pitch	Ordering Code		Dimensions mm			Anvil		Toolholder
IC	L mm	tpi	RH	LH	h min	X	Y	RH	LH	
1/4"	11	16	2IR16ACME...	2IL16ACME...	0.92	0.9	0.9	-	-	NVR..-2 (LH)
		16	3IR16ACME...	3IL16ACME...	0.92	1.0	1.1			
3/8"	16	14	3IR14ACME...	3IL14ACME...	1.03	1.1	1.2	Y13	YE3	AVR..-3 (LH)
		12	3IR12ACME...	3IL12ACME...	1.19	1.2	1.3			
		10	3IR10ACME...	3IL10ACME...	1.52	1.2	1.3			
		8	3IR8ACME...	3IL8ACME...	1.84	1.4	1.5			
		6	3IR6ACME...	3IL6ACME...	2.37	1.6	1.9	Y13AC6	YE3AC6	
1/2"	22	6	4IR6ACME...	4IL6ACME...	2.37	1.8	2.1	Y14	YE4	AVR..-4 (LH)
		5	4IR5ACME...	4IL5ACME...	2.79	2.0	2.3			
1/2"F	23	6	4FIR6ACME...		2.37	1.8	2.1	Y14F		AVRC...-4F
		5	4FIR5ACME...		2.79	2.0	2.3			
5/8"	27	4	5IR4ACME...	5IL4ACME...	3.43	2.3	2.6	Y15	YE5	AVR..-5 (LH)



FLINE

American ACME (con't)

Internal

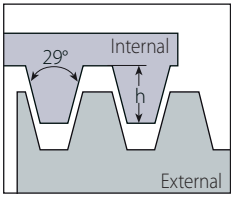

Defined by: ANSI B1.5:1988
Tolerance class: 3G

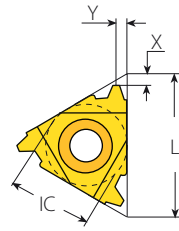

Standard

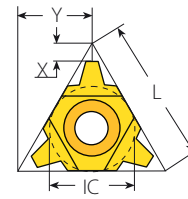

U Style

Coarse Pitch RH



Thread	Insert Size		Ordering Code	Dimensions mm			Anvil	Min Bore Dia.	
tpi	IC	L mm	RH	h min	X	Y	RH	Toolholder RH	mm
1/2"x10	6.0U	10	6.0UIR10ACME...158/005	1.52	1.0	5.2	-	NVRC8-6.0U-156/003	10.16
5/8"x8	1/4"U	11	2UIR8ACME...158/006	1.84	1.0	5.5	-	NVRC10-2U-156/004	12.70
3/4"x6	3/8"	16	3IR6ACME...	2.37	1.7	1.8	-	NVRC11-3-156/005	14.82
7/8"x6			3IR6ACME...	2.37	1.7	1.8	-	NVRC13-3-156/006	18.42
1"x5	1/2"	22	4IR5ACME...	2.79	2.0	2.3	-	NVRC17-4-156/007	20.32
1 1/8"x5			4IR5ACME...	2.79	2.0	2.3	-	NVRC20-4-156/008	24.00
1 1/4"x5			4IR5ACME...	2.79	2.0	2.3	-	NVRC20-4-156/009	27.18
1 1/2"x4	5/8"	27	5IR4ACME...	3.43	2.3	2.6	-	NVRC28-5-156/010	32.38
1 3/4"x4			5IR4ACME...	3.43	2.3	2.6	YI5-1P	AVRC32-5	38.74

Coarse Pitch LH



Thread	Insert Size		Ordering Code	Dimensions mm			Anvil	Min Bore Dia.	
tpi	IC	L mm	LH	h min	X	Y	LH	Toolholder LH	mm
1/2"x10	6.0U	10	6.0UIR10ACME...158/005	1.52	1.0	5.2	-	NVRC 8-6.0ULH-156/037	10.16
5/8"x8	1/4"U	11	2UIR8ACME...158/006	1.84	1.0	5.5	-	NVRC 10-2ULH-156/038	12.70
3/4"x6	3/8"	16	3IL6ACME...	2.37	1.7	1.8	-	NVRC 11-3LH-156/025	14.82
7/8"x6			3IL6ACME...	2.37	1.7	1.8	-	NVRC 13-3LH-156/028	18.42
1"x5	1/2"	22	4IL5ACME...	2.79	2.0	2.3	-	NVRC 17-4LH-156/023	20.32
1 1/8"x5			4IL5ACME...	2.79	2.0	2.3	-	NVRC 20-4LH-156/024	24.00
1 1/4"x5			4IL5ACME...	2.79	2.0	2.3	-	NVRC 20-4LH-156/033	27.18
1 1/2"x4	5/8"	27	5IL4ACME...	3.43	2.3	2.6	-	NVRC 28-5LH-156/034	32.38
1 3/4"x4			5IL4ACME...	3.43	2.3	2.6	YE5-1P	AVRC 32-5LH	38.74

U Type RH Inserts Can Be Used for Both LH and RH Applications.

U Style



Insert Size	Pitch	Ordering Code	Dimensions mm			Anvil			
IC	L mm	tpi	RH+LH	h min	X	Y	RH	LH	Toolholder
1/2"U	22	4	4UI4ACME...	3.43	2.3	11.0	YI4U	YE4U	AVR...4U (LH)
		3	4UI3ACME...	4.49	2.9	11.0			
5/8"U	27	3	5UI3ACME...	4.49	2.9	13.7	YI5U	YE5U	AVR...5U(LH)

American ACME (con't)

Internal

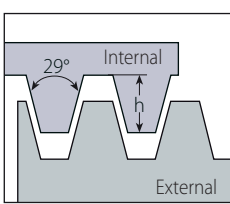

Defined by: ANSI B1.5:1988
Tolerance class: 3G

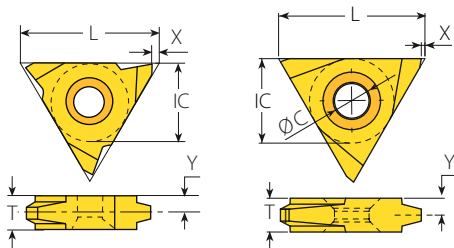

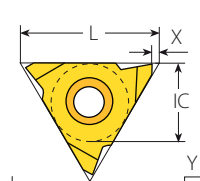

V Style

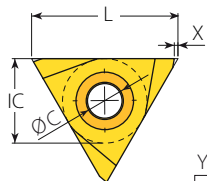

On Edge

V Style



Insert Size		Pitch	Ordering Code		Dimensions mm				Toolholder
IC	L mm	tpi	RH	LH	h min	X	Y	T	
5/8"V	27	4	5VIR4ACME...	5VIL4ACME...	3.43	1.0	3.3	6	NVR...-5V (LH)
		3.5	5VIR3.5ACME...	5VIL3.5ACME...	3.85	1.0	3.3	6	
		3	5VIR3ACME...	5VIL3ACME...	4.49	1.0	3.3	6	
		2	5VIR2ACME...	5VIL2ACME...	6.60	1.0	5.2	10	

On Edge



Insert Size		Pitch	Ordering Code		Dimensions mm				
IC	L mm	tpi	RH		h min	T	Ø C	X	Y
1/2"	22	12	TNEC43EI12ACME...		1.19	4.76	5.2	0.5	2.4
		10	TNEC43EI10ACME...		1.52				
		8	TNEC43EI8ACME...		1.83				
		6	TNEC43EI6ACME...		2.36				
		4	TNEC43EI4ACME...		3.43				
5/8"	27	4	TNEC54EI4ACME...		3.43	6.35	6.5	0.5	3.2
		3	TNEC54EI3ACME...		4.50				
3/4"	32	2	TNEC56EI2ACME...		6.60	9.53	8.0	0.5	4.8

On Edge inserts are suited to existing toolholders on the market.

American ACME (con't)

MINIPRO

Internal

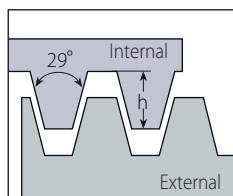

Defined by: ANSI B1.5:1988
Tolerance class: 3G

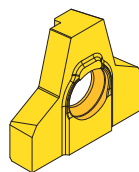

Mega Line

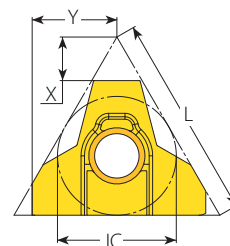

Internal

Insert Size	Pitch	Ordering Code	Dimensions mm			Number of Passes		
			IC	L mm	tpi	RH	h min	X
5/8" MG	27	2	5MGIR2ACME...	6.54	4.81	10.4	94	44
		1 1/2	5MGIR1-1/2ACME...	8.55	5.81		124	58
		1 1/3	5MGIR1-1/3ACME...	9.56	6.81		139	65
		1	5MGIR1ACME...	12.57	8.31		184	86

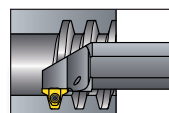

Internal Toolholders for American ACME

MEGALINE

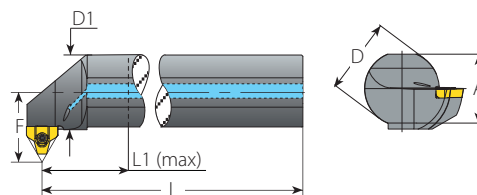
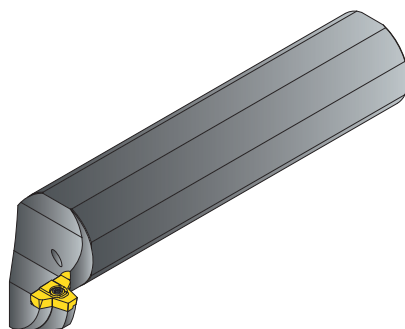

Internal

Insert	Ordering Code	Dimensions mm							Min. Bore Dia.	Thread Diameter Range (Min.-Max.)		Spare Parts	
		RH	A	L	L1 (max)	D	D1	F		mm	Short Chip Material	Long Chip Material	Insert Screw
5MGIR2ACME...	NVRC40-5MG2ACME	36	232.5	100	40	39.7	41.5	63.5	(3"-5")-2ACME	(3.5"-5")-2ACME	S5MG	K6T	
	NVRC50-5MG2ACME	46	257.5	125	50	49.7	46.5	76.2	(3.5"-5")-2ACME	(4"-5")-2ACME			
	NVRC60-5MG2ACME	57	282.5	150	60	59.7	51.5	88.9	(4"-5")-2ACME	(4.5"-5")-2ACME			
5MGIR1-1/2ACME...	NVRC40-5MG1-1/2ACME	36	232.5	100	40	39.7	41.5	59.3	(3"-5")-1 1/2ACME	(3.5"-5")-1 1/2ACME			
	NVRC50-5MG1-1/2ACME	46	257.5	125	50	49.7	46.5	72.0	(3.5"-5")-1 1/2ACME	(4"-5")-1 1/2ACME			
	NVRC60-5MG1-1/2ACME	57	282.5	150	60	59.7	51.5	84.7	(4"-5")-1 1/2ACME	(4.5"-5")-1 1/2ACME			
5MGIR1-1/3ACME...	NVRC40-5MG1-1/3ACME	36	232.5	100	40	39.7	41.5	57.2	(3"-5")-1 1/3ACME	(3.5"-5")-1 1/3ACME			
	NVRC50-5MG1-1/3ACME	46	257.5	125	50	49.7	46.5	69.9	(3.5"-5")-1 1/3ACME	(4.0"-5")-1 1/3ACME			
	NVRC60-5MG1-1/3ACME	57	282.5	150	60	59.7	51.5	82.6	(4.0"-5")-1 1/3ACME	(4.5"-5")-1 1/3ACME			
5MGIR1ACME...	NVRC40-5MG1ACME	36	232.5	100	40	39.7	41.5	63.5	(3.5"-5")-1ACME	(4"-5")-1ACME			
	NVRC50-5MG1ACME	46	257.5	125	50	49.7	46.5	76.2	(4"-5")-1ACME	(4.5"-5")-1ACME			
	NVRC60-5MG1ACME	57	282.5	150	60	59.7	51.5	76.2	(4"-5")-1ACME	(4.5"-5")-1ACME			

Recommended thread infeed method for Mega Line: Flank or Modified Flank 1°.

American ACME (con't)

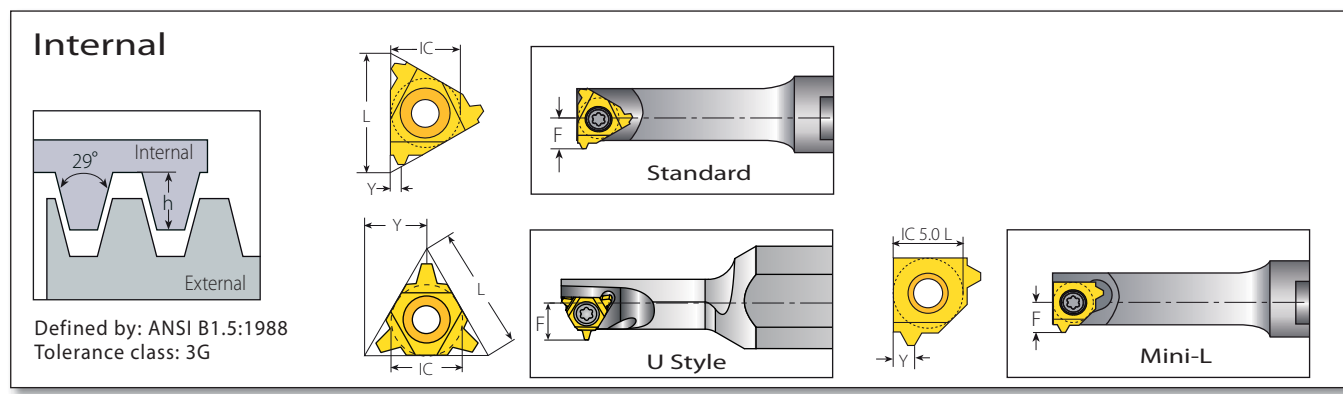

Mini-3 Standard



Insert Size		Pitch	Ordering Code		Dimensions mm			Min. Bore Dia.	
IC mm	L mm	tpi	RH	LH	h min	Y	F	mm	Toolholder
5.0	8	16	5.0KIR16ACME...	5.0KIL16ACME...	0.92	0.7	4.7	7.8	.NVRC 7-5.0K (LH)
6.0	10	12	6.0IR12ACME...		1.19	1.1	5.1	10.0	.NVR1.-6.0

Left handed tool supplied by request (Example: 6.0L12ACME...).

Mini-3 U Style



Insert Size		Pitch	Ordering Code		Dimensions mm			Min. Bore Dia.	
IC mm	L mm	tpi	RH+LH		h min	Y	F	mm	Toolholder
5.0U	8	14	5.0KUI14ACME...		1.03	4.0	5.8	9.0	.NVRC 8-5.0KU (LH)
		12	5.0KUI12ACME...		1.19				
		10	5.0KUI10ACME...		1.52				

Mini-L



Insert Size		Pitch	Ordering Code		Dimensions mm			Min. Bore Dia.	
IC mm		tpi	RH	LH	h min	Y	F	mm	Toolholder
5.0L		12	5LIR12ACME...		1.19	1.1	4.42	8.0	.NVR 10. -5L

Left handed tool supplied by request (Example: 5LIL12ACME...).

American ACME (2G)

External

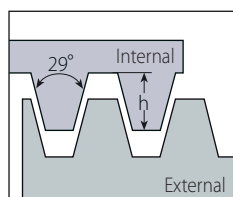

Defined by: ANSI B1.5:1988
Tolerance class: 2G

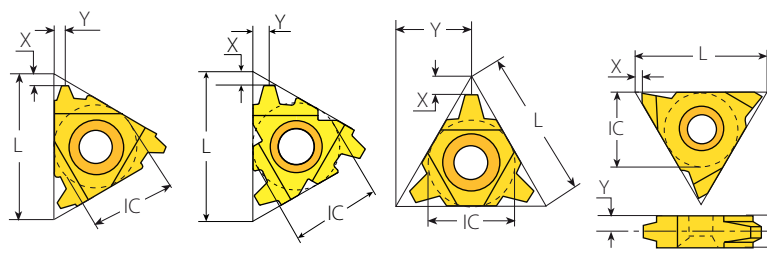

Standard

F-Line

U Style

V Style

Standard



FLINE

Insert Size		Pitch	Ordering Code		Dimensions mm			Anvil		Toolholder
IC	L mm	tpi	RH	LH	h min	X	Y	RH	LH	
3/8"	16	10	3ER10ACME-2G...	3EL10ACME-2G...	1.52	1.3	1.4	YE3	YI3	AL...-3 (LH)
		8	3ER8ACME-2G...	3EL8ACME-2G...	1.84	1.4	1.5			
1/2"	22	5	4ER5ACME-2G...	4EL5ACME-2G...	2.79	2.0	2.3	YE4	YI4	AL...-4 (LH)
1/2"F	23	5	4FER5ACME-2G...		2.79	2.0	2.3	YE4F		AL...-4F

U Style



Insert Size		Pitch	Ordering Code		Dimensions mm			Anvil		Toolholder
IC	L mm	tpi	RH+LH		h min	X	Y	RH	LH	
1/2"U	22	4	4UE4ACME-2G...		3.43	2.3	11.0	YE4U	YI4U	AL...-4U (LH)
		3.5	4UE3.5ACME-2G...		3.85	2.6	11.0			
		3	4UE3ACME-2G...		4.49	3.0	11.0			

V Style



Insert Size		Pitch	Ordering Code		Dimensions mm				Toolholder
IC	L mm	tpi	RH	LH	h min	X	Y	T	
5/8"V	27	4	5VER4ACME-2G...	5VEL4ACME-2G...	3.43	1.0	3.3	6	NL...-5V-6 (LH)
		3.5	5VER3.5ACME-2G...	5VEL3.5ACME-2G...	3.85	1.0	3.3	6	
		3	5VER3ACME-2G...	5VEL3ACME-2G...	4.49	1.0	3.3	6	

American ACME (2G) (con't)

Internal

Defined by: ANSI B1.5:1988
Tolerance class: 2G

Standard F-Line U Style V Style

Standard

Insert Size		Pitch	Ordering Code		Dimensions mm			Anvil		Toolholder
IC	L mm	tpi	RH	LH	h min	X	Y	RH	LH	
3/8"	16	10	3IR10ACME-2G...	3IL10ACME-2G...	1.52	1.2	1.3	YI3	YE3	AVR..-3 (LH)
		8	3IR8ACME-2G...	3IL8ACME-2G...	1.84	1.4	1.5			
1/2"	22	5	4IR5ACME-2G...	4IL5ACME-2G...	2.79	2.0	2.3	YI4	YE4	AVR..-4 (LH)
1/2"F	23	5	4FIR5ACME-2G...		2.79	2.0	2.3	YI4F		AVRC...-4F

F LINE

U Style

Insert Size		Pitch	Ordering Code		Dimensions mm			Anvil		Toolholder
IC	L mm	tpi	RH+LH		h min	X	Y	RH	LH	
1/2"U	22	4	4UI4ACME-2G...		3.43	2.3	11.0	YI4U	YE4U	AVR..-4U (LH)
		3.5	4UI3.5ACME-2G...		3.85	2.6	11.0			
		3	4UI3ACME-2G...		4.49	2.9	11.0			



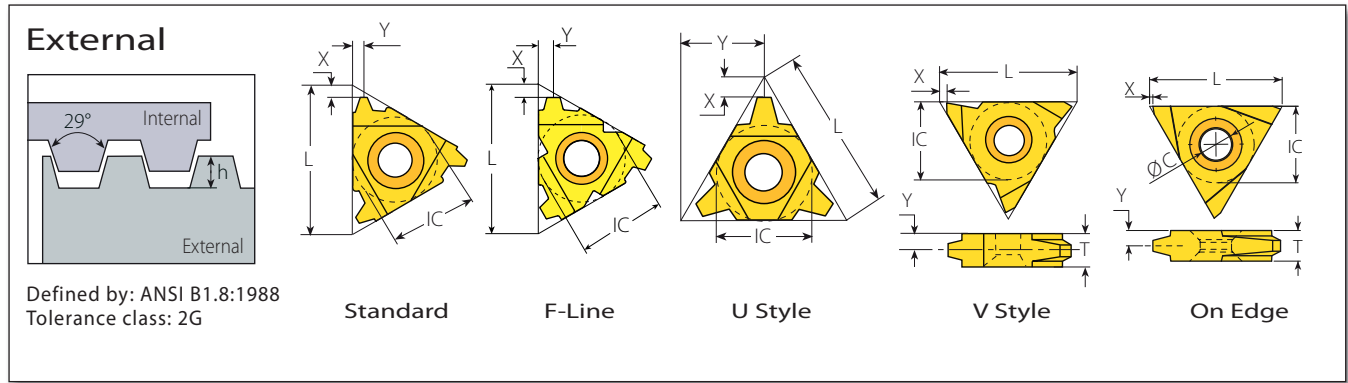

V Style

Insert Size		Pitch	Ordering Code		Dimensions mm				Toolholder
IC	L mm	tpi	RH	LH	h min	X	Y	T	
5/8"V	27	4	5VIR4ACME-2G...	5VIL4ACME-2G...	3.43	1.0	3.3	6	NVR..-5V (LH)
		3.5	5VIR3.5ACME-2G...	5VIL3.5ACME-2G...	3.85	1.0	3.3	6	
		3	5VIR3ACME-2G...	5VIL3ACME-2G...	4.49	1.0	3.3	6	

Stub ACME



Standard

IC	Insert Size		Pitch	Ordering Code		Dimensions mm			Anvil		Toolholder	
	L mm	tpi		RH	LH	h min	X	Y	RH	LH		
	3/8"	11	16	2ER16STACME...	2EL16STACME...	0.60	1.0	1.0	-	-	NL...-2 (LH)	
				3ER16STACME...	3EL16STACME...	0.60	1.0	1.0				
				14	3ER14STACME...	3EL14STACME...	0.67	1.1	1.1			
				12	3ER12STACME...	3EL12STACME...	0.76	1.2	1.2	YE3		YI3
				10	3ER10STACME...	3EL10STACME...	1.02	1.2	1.3			
				8	3ER8STACME...	3EL8STACME...	1.21	1.4	1.5			
	1/2"	22	6	4ER6STACME...	4EL6STACME...	1.52	1.7	1.8	YE4	YI4	AL...-4 (LH)	
				5	4ER5STACME...	4EL5STACME...	1.78	2.1				2.3
				4	4ER4STACME...	4EL4STACME...	2.16	2.3				2.3
	1/2"	23	6	4FER6STACME...		1.52	1.7	1.8	YE4F		AL...-4F	
				5	4FER5STACME...		1.78	2.1				2.3
				4	4FER4STACME...		2.16	2.3				2.3
	5/8"	27	4	5ER4STACME...	5EL4STACME...	2.16	2.3	2.4	YE5	YI5	AL...-5 (LH)	
				3	5ER3STACME...	5EL3STACME...	2.79	2.9				2.9

U Style

IC	Insert Size		Pitch	Ordering Code		Dimensions mm			Anvil		Toolholder
	L mm	tpi		RH+LH	h min	X	Y	RH	LH		
	1/2"U	22	4	4UE4STACME...		2.16	2.6	11.0	YE4U	YI4U	AL...-4U (LH)
				3	4UE3STACME...		2.79	3.4			

V Style

IC	Insert Size		Pitch	Ordering Code		Dimensions mm				Toolholder	
	L mm	tpi		RH	LH	h min	X	Y	T		
	5/8"V	27	4	5VER4STACME...	5VEL4STACME...	2.16	1.0	3.3	6	NL...-5V-6 (LH)	
				3	5VER3STACME...	5VEL3STACME...	2.79	1.0	3.3		6
				2	5VER2STACME...	5VEL2STACME...	4.06	1.0	4.3		8

On Edge

IC	Insert Size		Pitch	Ordering Code		Dimensions mm				
	L mm	tpi		RH	h min	T	ØC	X	Y	
	3/8"	16	12	TNEC32EI12STACME...	0.76	3.18	3.8	1.0	1.6	
				10	TNEC32EI10STACME...					1.02
				8	TNEC32EI8STACME...					1.22
<td rowspan="4">1/2"</td> <td rowspan="4">22</td> <td rowspan="4">12</td> <td>TNEC43EI12STACME...</td> <td>0.76</td> <td rowspan="4">4.76</td> <td rowspan="4">5.2</td> <td rowspan="4">0.5</td> <td rowspan="4">2.4</td>	1/2"	22	12	TNEC43EI12STACME...	0.76	4.76	5.2	0.5	2.4	
				10	TNEC43EI10STACME...					1.02
				8	TNEC43EI8STACME...					1.22
				6	TNEC43EI6STACME...					1.52
<td rowspan="2">5/8"</td> <td rowspan="2">27</td> <td rowspan="2">4</td> <td>TNEC43EI4STACME...</td> <td>2.16</td> <td rowspan="2">6.35</td> <td rowspan="2">6.5</td> <td rowspan="2"></td> <td rowspan="2">3.2</td>	5/8"	27	4	TNEC43EI4STACME...	2.16	6.35	6.5		3.2	
				TNEC54EI4STACME...	2.16					

On Edge inserts are suited to existing toolholders on the market.

Stub ACME (con't)

MEGA/LINE

External

Defined by: ANSI B1.8:1988
Tolerance class: 2G

Mega Line

External

Insert Size	Pitch		Ordering Code	Dimensions mm			Number of Passes		
	IC	L mm		tpi	RH	h min	X	Y	0.07mm–Min. Depth of Cut (On radius)
5/8" MG	27	1	5MGER1STACME...		7.87	9.51	11.3	113	53

External Toolholders for Stub ACME

MEGA/LINE

External

Insert	Ordering Code	Dimensions mm				Thread Diameter Range (Min.-Max.)	Spare Parts	
		RH	H=B=H1	F	L1		L2	Insert Screw
5MGER1STACME...	NL25-5MG1STACME	25	16.5	155		(3.5"-5")-1STACME	S5MG	K6T
	NL32-5MG1STACME	32	23.5	175	22			
	NL40-5MG1STACME	40	31.5	205				

Recommended thread infeed method for Mega Line: Flank or Modified Flank 1°.

Stub ACME (con't)

Internal

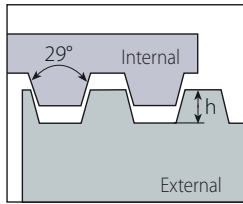

Defined by: ANSI B1.8:1988
Tolerance class: 2G

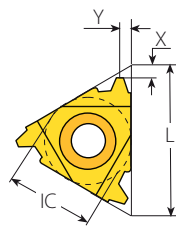

Standard

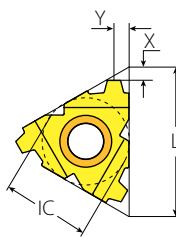

F-Line

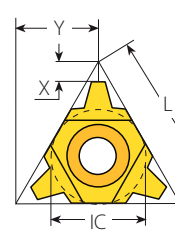

U Style

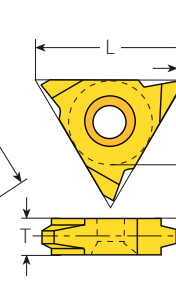

V Style

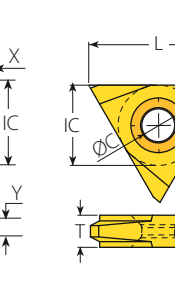

On Edge

Standard

IC	L mm	Pitch tpi	Ordering Code		Dimensions mm			Anvil		Toolholder		
			RH	LH	h min	X	Y	RH	LH			
1/4"	11	16	2IR16STACME...	2IL16STACME...	0.60	1.0	1.0	-	-	NVR..-2 (LH)		
			3IR16STACME...	3IL16STACME...	0.60	1.0	1.0					
		3/8"	16	14	3IR14STACME...	3IL14STACME...	0.67	1.1	1.1			
				12	3IR12STACME...	3IL12STACME...	0.76	1.1	1.2	YI3	YE3	AVR..-3 (LH)
				10	3IR10STACME...	3IL10STACME...	1.02	1.2	1.3			
				8	3IR8STACME...	3IL8STACME...	1.21	1.4	1.5			
1/2"	22	6	4IR6STACME...	4IL6STACME...	1.52	1.7	1.8					
		5	4IR5STACME...	4IL5STACME...	1.78	2.1	2.3	YI4	YE4	AVR..-4 (LH)		
		4	4IR4STACME...	4IL4STACME...	2.16	2.3	2.3					
1/2" ^F	23	6	4FIR6STACME...		1.52	1.7	1.8					
		5	4FIR5STACME...		1.78	2.1	2.3	YI4 ^F		AVRC...-4 ^F		
		4	4FIR4STACME...		2.16	2.3	2.3					
5/8"	27	4	5IR4STACME...	5IL4STACME...	2.16	2.3	2.4	YI5	YE5	AVR..-5 (LH)		
		3	5IR3STACME...	5IL3STACME...	2.79	2.9	2.9					

U Style

IC	L mm	Pitch tpi	Ordering Code		Dimensions mm			Anvil		Toolholder
			RH+LH		h min	X	Y	RH	LH	
1/2" ^U	22	4	4UI4STACME...		2.16	2.5	11.0	YI4U	YE4U	AVR..-4U (LH)
		3	4UI3STACME...		2.79	3.3	11.0			

V Style

IC	L mm	Pitch tpi	Ordering Code		Dimensions mm				Toolholder
			RH	LH	h min	X	Y	T	
5/8" ^V	27	4	5VIR4STACME...	5VIL4STACME...	2.16	1.0	3.3	6	NVR...-5V (LH)
		3	5VIR3STACME...	5VIL3STACME...	2.79	1.0	3.3	6	
		2	5VIR2STACME...	5VIL2STACME...	4.06	1.0	4.3	8	

On Edge

IC	L mm	Pitch tpi	Ordering Code		Dimensions mm				
			RH		h min	T	ØC	X	Y
3/8"	16	12	TNEC32E112STACME...		0.76	3.175	3.8	1	1.6
		10	TNEC32E110STACME...		1.02				
		8	TNEC32E108STACME...		1.22				
1/2"	22	12	TNEC43E112STACME...		0.76	4.76	5.2	0.5	2.4
		10	TNEC43E110STACME...		1.02				
		8	TNEC43E108STACME...		1.22				
		6	TNEC43E106STACME...		1.52				
5/8"	27	4	TNEC43E104STACME...		2.16	6.35	6.5		3.2
		4	TNEC54E104STACME...		2.16				

On Edge inserts are suited to existing toolholders on the market.

Stub ACME (con't)

MEGALINE

Internal

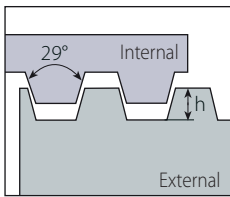

Defined by: ANSI B1.8:1988
Tolerance class: 2G

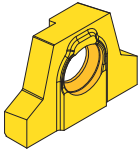

Mega Line

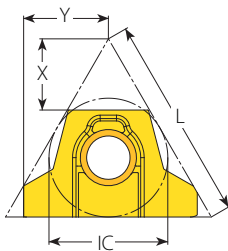

Internal



Insert Size		Pitch	Ordering Code	Dimensions mm			Number of Passes	
IC	L mm	tpi	RH	h min	X	Y	0.07mm–Min. Depth of Cut (On radius)	0.15mm–Max. Depth of Cut (On radius)
5/8" MG	27	1	5MGIR1STACME...	7.82	9.51	10.4	113	53

Internal Toolholders for Stub ACME

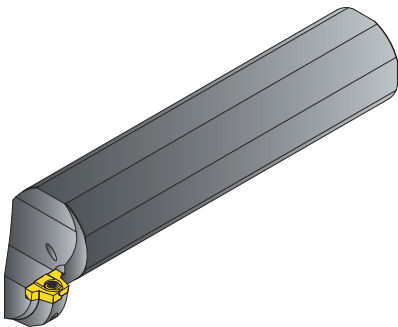
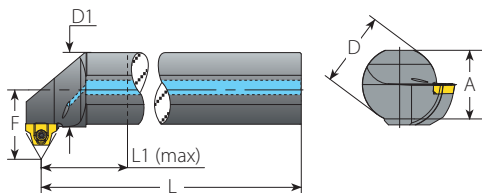
Internal

Insert	Ordering Code	Dimensions						Min. Bore Dia.	Thread Diameter Range (Min.-Max.)		Spare Parts	
		A	L	L1 (max)	D	D1	F		mm	Short Chip Material	Long Chip Material	Insert Screw
5MGIR 1STACME...	NVRC40-5MG1STACME	36	232.5	100	40	39.7	41.5	73.7	(3.5"-5")-1STACME	(3.5"-5")-1STACME	S5MG	K6T
	NVRC50-5MG1STACME	46	257.5	125	50	49.7	46.5	73.7	(3.5"-5")-1STACME	(4.0"-5")-1STACME		
	NVRC60-5MG1STACME	57	282.5	150	60	59.7	51.5	86.4	(4.0"-5")-1STACME	(4.5"-5")-1STACME		

Recommended thread infeed method for Mega Line: Flank or Modified Flank 1°.

Stub ACME (con't)

MINIPRO

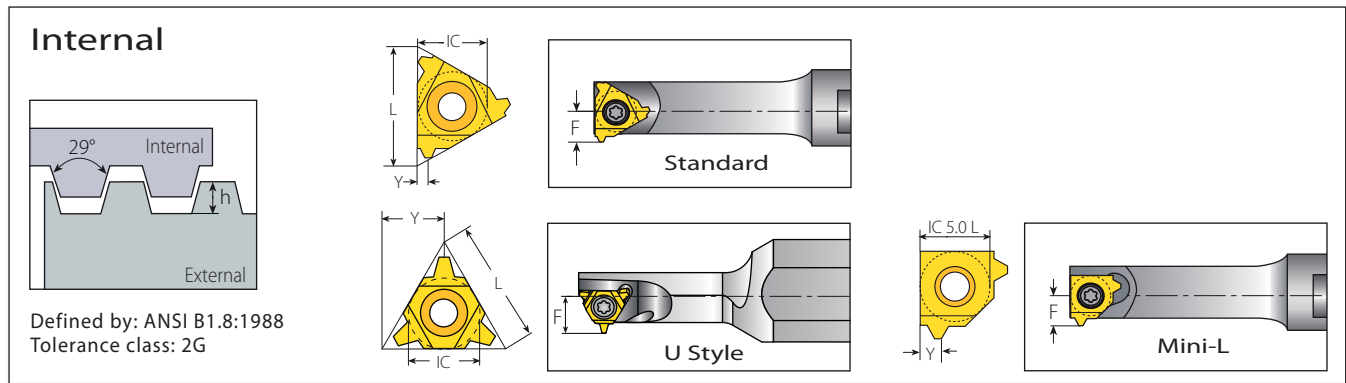

Mini-3 Standard



Insert Size		Pitch	Ordering Code		Dimensions mm			Min. Bore Dia.	
IC mm	L mm	tpi	RH	LH	h min	Y	F	mm	Toolholder
5.0	8	16	5.0KIR16STACME...	5.0KIL16STACME...	0.6	0.7	4.7	7.8	.NVRC 7-5.0K(LH)
6.0	10	12	6.0IR12STACME...		0.76	1.2	5.1	10.0	.NVR1..-6.0

Left handed tool supplied by request (Example: 6.0IL12STACME...).

Mini-3 U Style



Insert Size		Pitch	Ordering Code	Dimensions mm	Min. Bore Dia.			
IC mm	L mm	tpi	RH+LH	h min	Y	F	mm	Toolholder
5.0U	8	14	5.0KUI14STACME...	0.67		5.8		
		12	5.0KUI12STACME...	0.76	4.0	5.7	9.0	.NVRC 8-5.0KU(LH)
		10	5.0KUI10STACME...	1.02		5.6		

Mini-L



Insert Size		Pitch	Ordering Code	Dimensions mm	Min. Bore Dia.			
IC mm	tpi	RH	LH	h min	Y	F	mm	Toolholder
5.0L	12	5LIR12STACME...		0.76	1.2	4.42	8.0	.NVR 10. -5L

Left handed tool supplied by request (Example: 5LIL12STACME...).

UNJ - UNJC, UNJF, UNJEF, UNJS

External

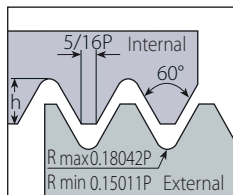

Defined by: MIL-S-8879C
Tolerance class: 3A/3B

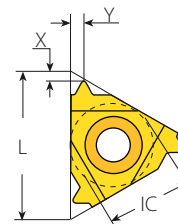

Standard

Standard

Insert Size		Pitch	Ordering Code		Dimensions mm			Anvil		Toolholder					
IC	L mm	tpi	RH	LH	h min	X	Y	RH	LH						
1/4"	11	48	2ER48UNJ...	2EL48UNJ...	0.31	0.6	0.5	-	-	NL...-2 (LH)					
		44	2ER44UNJ...	2EL44UNJ...	0.33	0.6	0.6								
		40	2ER40UNJ...	2EL40UNJ...	0.37	0.6	0.6								
		36	2ER36UNJ...	2EL36UNJ...	0.41	0.6	0.6								
		32	2ER32UNJ...	2EL32UNJ...	0.46	0.6	0.7								
		28	2ER28UNJ...	2EL28UNJ...	0.52	0.7	0.7								
		24	2ER24UNJ...	2EL24UNJ...	0.61	0.7	0.8								
		20	2ER20UNJ...	2EL20UNJ...	0.73	0.8	0.9								
		18	2ER18UNJ...	2EL18UNJ...	0.81	0.8	1.0								
		16	2ER16UNJ...	2EL16UNJ...	0.92	0.9	1.1								
		14	2ER14UNJ...	2EL14UNJ...	1.05	1.0	1.2								
		3/8"	16	48	3ER48UNJ...	3EL48UNJ...	0.31				0.6	0.5	YE3	YI3	AL...-3 (LH)
				44	3ER44UNJ...	3EL44UNJ...	0.33				0.6	0.6			
				40	3ER40UNJ...	3EL40UNJ...	0.37				0.6	0.6			
36	3ER36UNJ...			3EL36UNJ...	0.41	0.6	0.6								
32	3ER32UNJ...			3EL32UNJ...	0.46	0.6	0.7								
28	3ER28UNJ...			3EL28UNJ...	0.52	0.7	0.7								
24	3ER24UNJ...			3EL24UNJ...	0.61	0.7	0.8								
20	3ER20UNJ...			3EL20UNJ...	0.73	0.8	0.9								
18	3ER18UNJ...			3EL18UNJ...	0.81	0.8	1.0								
16	3ER16UNJ...			3EL16UNJ...	0.92	0.9	1.1								
14	3ER14UNJ...			3EL14UNJ...	1.05	1.0	1.2								
13	3ER13UNJ...			3EL13UNJ...	1.13	1.0	1.3								
12	3ER12UNJ...			3EL12UNJ...	1.22	1.1	1.3								
11	3ER11UNJ...			3EL11UNJ...	1.33	1.2	1.5								
10	3ER10UNJ...	3EL10UNJ...	1.47	1.2	1.5										
9	3ER9UNJ...	3EL9UNJ...	1.63	1.3	1.7										
8	3ER8UNJ...	3EL8UNJ...	1.83	1.2	1.6										



UNJ - UNJC, UNJF, UNJEF, UNJS (con't)

External

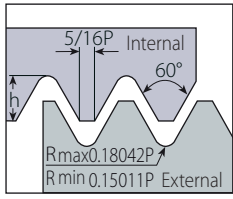

Defined by: MIL-S-8879C
Tolerance class: 3A/3B

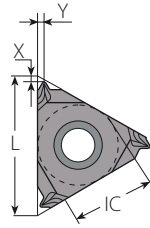

SCB
Sintered
Chipbreaker

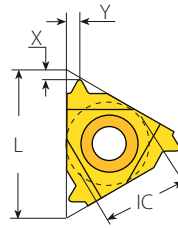

Standard

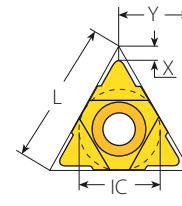

U Style

Standard



Insert Size		Pitch	Ordering Code		Dimensions mm			Anvil		Toolholder
IC	L mm	tpi	RH	LH	h min	X	Y	RH	LH	
3/8" SCB	16	36	3JER36UNJ...		0.41	1.3	0.5	YE3	-	AL..-3
		32	3JER32UNJ...		0.46	1.2	0.5			
		28	3JER28UNJ...		0.52	0.7	0.8			
		24	3JER24UNJ...		0.61	0.7	0.8			
		20	3JER20UNJ...		0.73	0.7	0.8			
		18	3JER18UNJ...		0.81	0.7	0.8			
		16	3JER16UNJ...		0.92	0.8	0.8			
		14	3JER14UNJ...		1.05	1.3	1.5			
		12	3JER12UNJ...		1.22	1.3	1.5			
		10	3JER10UNJ...		1.47	1.3	1.5			
1/2"	22	7	4ER7UNJ...	4EL7UNJ...	2.09	1.7	2.3	YE4	Y14	AL..-4 (LH)
		6	4ER6UNJ...	4EL6UNJ...	2.44	1.7	2.3			
		5	4ER5UNJ...	4EL5UNJ...	2.93	1.8	2.5			
5/8"	27	4.5	5ER4.5UNJ...	5EL4.5UNJ...	3.26	2.0	2.7	YE5	Y15	AL..-5 (LH)
		4	5ER4UNJ...	5EL4UNJ...	3.67	2.2	3.1			



U Style



Insert Size		Pitch	Ordering Code		Dimensions mm			Anvil		Toolholder
IC	L mm	tpi	RH+LH		h min	X	Y	RH	LH	
1/2"U	22	4.5	4UE4.5UNJ...		3.26	2.1	11.0	YE4U	Y14U	AL..-4U (LH)
		4	4UE4UNJ...		3.67	2.2	11.0			

UNJ - UNJC, UNJF, UNJEF, UNJS (con't)

Internal

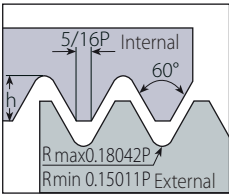

Defined by: MIL-S-8879C
Tolerance class: 3A/3B

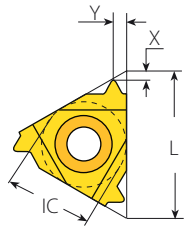

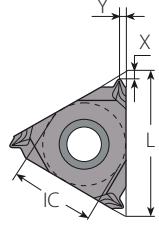

Standard



**SCB
Sintered
Chipbreaker**

Standard

Insert Size		Pitch	Ordering Code		Dimensions mm			Anvil		Toolholder	
IC	L mm	tpi	RH	LH	h min	X	Y	RH	LH		
	1/4"	11	48	2IR48UNJ...	2IL48UNJ...	0.28	0.6	0.5	-	-	NVR..-2 (LH)
			44	2IR44UNJ...	2IL44UNJ...	0.30	0.6	0.6			
			40	2IR40UNJ...	2IL40UNJ...	0.33	0.6	0.6			
			36	2IR36UNJ...	2IL36UNJ...	0.37	0.6	0.6			
			32	2IR32UNJ...	2IL32UNJ...	0.42	0.6	0.7			
			28	2IR28UNJ...	2IL28UNJ...	0.47	0.7	0.7			
			24	2IR24UNJ...	2IL24UNJ...	0.55	0.7	0.8			
			20	2IR20UNJ...	2IL20UNJ...	0.66	0.8	0.9			
			18	2IR18UNJ...	2IL18UNJ...	0.74	0.8	1.0			
			16	2IR16UNJ...	2IL16UNJ...	0.83	0.9	1.1			
 <p>SCB</p>	1/4" SCB	11	36	2JIR36UNJ...		0.37	1.1	0.5	-	-	NVR..-2
			32	2JIR32UNJ...		0.42	1.2	0.5			
			28	2JIR28UNJ...		0.47	0.6	0.8			
			24	2JIR24UNJ...		0.55	0.6	0.8			
			20	2JIR20UNJ...		0.66	0.6	0.8			
			18	2JIR18UNJ...		0.74	0.6	0.8			
			16	2JIR16UNJ...		0.83	0.6	0.8			
			14	2JIR14UNJ...		0.95	0.6	0.8			

UNJ - UNJC, UNJF, UNJEF, UNJS (con't)

Internal

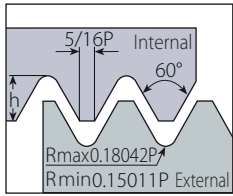

Defined by: MIL-S-8879C
Tolerance class: 3A/3B

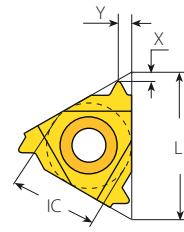

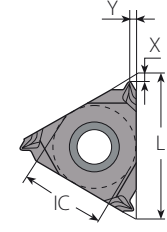

Standard



SCB
Sintered
Chipbreaker

Standard

Insert Size		Pitch	Ordering Code		Dimensions mm			Anvil		Toolholder	
IC	L mm	tpi	RH	LH	h min	X	Y	RH	LH		
	3/8"	16	48	3IR48UNJ...	3IL48UNJ...	0.28	0.6	0.5	YI3	YE3	AVR..-3 (LH)
			44	3IR44UNJ...	3IL44UNJ...	0.30	0.6	0.6			
			40	3IR40UNJ...	3IL40UNJ...	0.33	0.6	0.6			
			36	3IR36UNJ...	3IL36UNJ...	0.37	0.6	0.6			
			32	3IR32UNJ...	3IL32UNJ...	0.42	0.6	0.7			
			28	3IR28UNJ...	3IL28UNJ...	0.47	0.7	0.7			
			24	3IR24UNJ...	3IL24UNJ...	0.55	0.7	0.8			
			20	3IR20UNJ...	3IL20UNJ...	0.66	0.8	0.9			
			18	3IR18UNJ...	3IL18UNJ...	0.74	0.8	1.0			
			16	3IR16UNJ...	3IL16UNJ...	0.83	0.9	1.1			
			14	3IR14UNJ...	3IL14UNJ...	0.95	1.0	1.2			
			13	3IR13UNJ...	3IL13UNJ...	1.02	1.0	1.3			
			12	3IR12UNJ...	3IL12UNJ...	1.11	1.1	1.3			
			11	3IR11UNJ...	3IL11UNJ...	1.21	1.2	1.5			
			10	3IR10UNJ...	3IL10UNJ...	1.33	1.2	1.5			
			9	3IR9UNJ...	3IL9UNJ...	1.48	1.3	1.7			
	3/8" SCB	16	28	3JIR28UNJ...		0.47	0.6	0.8	YI3	-	AVR..-3
			24	3JIR24UNJ...		0.55	0.6	0.8			
			20	3JIR20UNJ...		0.66	0.6	0.8			
			18	3JIR18UNJ...		0.74	0.6	0.8			
			16	3JIR16UNJ...		0.83	0.6	0.8			
			14	3JIR14UNJ...		0.95	1.1	1.5			
			12	3JIR12UNJ...		1.11	1.1	1.5			
			10	3JIR10UNJ...		1.33	1.1	1.5			
	1/2"	22	7	4IR7UNJ...	4IL7UNJ...	1.90	1.7	2.3	YI4	YE4	AVR..-4 (LH)
			6	4IR6UNJ...	4IL6UNJ...	2.21	1.7	2.3			
			5	4IR5UNJ...	4IL5UNJ...	2.66	1.8	2.5			
			5/8"	27	4.5	5IR4.5UNJ...	5IL4.5UNJ...	2.95			
4	5IR4UNJ...	5IL4UNJ...			3.32	2.2	2.4				

UNJ - UNJC, UNJF, UNJEF, UNJS (con't)

Internal

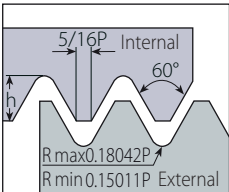

Defined by: MIL-S-8879C
Tolerance class: 3A/3B

U Style

U Style



Insert Size	Pitch	Ordering Code			Dimensions mm			Anvil		Toolholder
		IC	L mm	tpi	RH+LH	h min	X	Y	RH	
1/2"U	22		4.5	4UI4.5UNJ...	2.95	2.1	11.0	Y14U	YE4U	AVR...-4U (LH)
			4	4UI4UNJ...	3.32	2.2	11.0			

UNJ - UNJC, UNJF, UNJEF, UNJS

MINIPRO

Internal

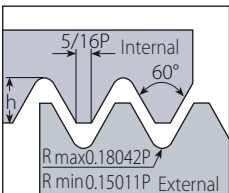
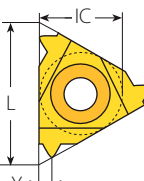
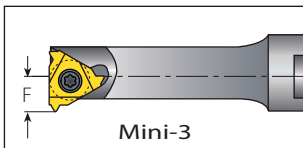
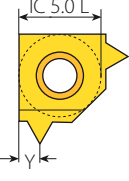
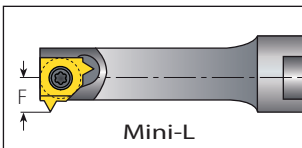
Defined by: MIL-S-8879C
Tolerance class: 3A/3B

Mini-3 Standard



Insert Size	Pitch	Ordering Code		Dimensions mm			Min. Bore Dia.	Toolholder		
		IC mm	L mm	tpi	RH	LH	h min		Y	F
6.0	10	20	6.0IR20UNJ...			0.66	0.9	4.90	9.8	.NVR1..-6.0

Left handed tool supplied by request (Example: 6.0IL20UNJ...).

Mini-L



Insert Size	Pitch	Ordering Code		Dimensions mm			Min. Bore Dia.	Toolholder			
		IC mm	tpi	RH	LH	h min	Y		F	mm	
5.0L	32	5LIR32UNJ...				0.42	0.6	3.92	7.6	.NVR 10..-5L	
	28	5LIR28UNJ...				0.47	0.6	3.99	7.6		
	24	5LIR24UNJ...					0.55	0.8	4.20		7.6
	20	5LIR20UNJ...					0.66	0.9	4.21		7.7
	18	5LIR18UNJ...					0.74	1.0	4.30		7.8
	16	5LIR16UNJ...					0.83	1.0	4.41		7.8
	14	5LIR14UNJ...				0.95	1.0	4.54	7.9		

Left handed tool supplied by request (Example: 5LIL32UNJ...).

MJ

External

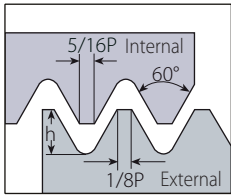

Defined by: ISO 5855
Tolerance class: 4h/6h-4H/5H

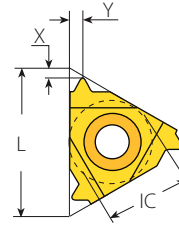

Standard

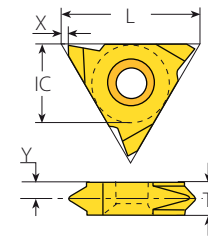

Slim Throat

Standard



Insert Size		Pitch	Ordering Code		Dimensions mm			Anvil		Toolholder
IC	L mm	mm	RH	LH	h min	X	Y	RH	LH	
1/4"	11	1.0	2ER1.0MJ...	2EL1.0MJ...	0.58	0.7	0.7	-	-	NL..-2 (LH)
		1.25	2ER1.25MJ...	2EL1.25MJ...	0.72	0.8	0.9			
		1.5	2ER1.5MJ...	2EL1.5MJ...	0.87	0.8	1.0			
3/8"	16	0.7	3ER0.7MJ...	3EL0.7MJ...	0.40	0.6	0.6	YE3	YI3	AL..-3 (LH)
		0.8	3ER0.8MJ...	3EL0.8MJ...	0.45	0.7	0.7			
		1.0	3ER1.0MJ...	3EL1.0MJ...	0.58	0.7	0.7			
		1.25	3ER1.25MJ...	3EL1.25MJ...	0.72	0.8	0.9			
		1.5	3ER1.5MJ...	3EL1.5MJ...	0.87	0.8	1.0			
		2.0	3ER2.0MJ...	3EL2.0MJ...	1.15	1.0	1.3			
		2.5	3ER2.5MJ...	3EL2.5MJ...	1.49	1.1	1.5			
		3.0	3ER3.0MJ...	3EL3.0MJ...	1.73	1.2	1.6			

Slim Throat



Insert Size		Pitch	Ordering Code		Dimensions mm				Toolholder
IC	L mm	mm	RH	LH	h min	X	Y	T	
1/4"V	11	0.7	2VER0.7MJ	2VEL0.7MJ	0.40	0.7	2.5	3.2	NL..-2V (LH)
		0.8	2VER0.8MJ	2VEL0.8MJ	0.44	0.7	2.5	3.2	
		0.9	2VER0.9MJ	2VEL0.9MJ	0.53	0.7	2.6	3.2	
		1.0	2VER1.0MJ	2VEL1.0MJ	0.58	0.7	2.5	3.2	
		1.25	2VER1.25MJ	2VEL1.25MJ	0.72	0.7	2.3	3.2	
		1.5	2VER1.5MJ	2VEL1.5MJ	0.87	0.7	2.2	3.2	

MJ (con't)

Internal

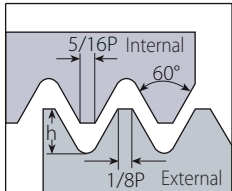
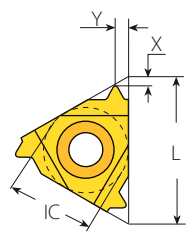
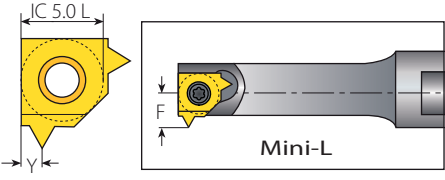
Defined by: ISO 5855
Tolerance class: 4h/6h-4H/5H

Standard

Standard

Insert Size		Pitch	Ordering Code		Dimensions mm			Anvil		Toolholder	
IC mm	L mm	mm	RH	LH	h min	X	Y	RH	LH		
	1/4"	11	1.0	2IR1.0MJ...	2IL1.0MJ...	0.49	0.6	0.7	-	-	NVR..-2 (LH)
			1.25	2IR1.25MJ...	2IL1.25MJ...	0.61	0.8	0.9			
			1.5	2IR1.5MJ...	2IL1.5MJ...	0.73	0.8	1.0			
			2.0	2IR2.0MJ...	2IL2.0MJ...	0.97	0.8	1.0			
3/8"	16	0.75	3IR0.75MJ...	3IL0.75MJ...	0.37	0.6	0.6	Y13	YE3	AVR..-3 (LH)	
		0.8	3IR0.8MJ...	3IL0.8MJ...	0.44	0.7	0.7				
		1.0	3IR1.0MJ...	3IL1.0MJ...	0.49	0.6	0.7				
		1.25	3IR1.25MJ...	3IL1.25MJ...	0.61	0.8	0.9				
		1.5	3IR1.5MJ...	3IL1.5MJ...	0.73	0.8	1.0				
		2.0	3IR2.0MJ...	3IL2.0MJ...	0.97	0.8	1.3				
		3.0	3IR3.0MJ...	3IL3.0MJ...	1.46	1.2	1.6				

Mini - L

MINIPRO

Insert Size		Pitch	Ordering Code		Dimensions mm			Min. Bore Dia.	Toolholder
IC mm		mm	RH	LH	h min	Y	F	mm	
	5.0L	1.0	5LIR1.0MJ...		0.49	0.7	4.06	7.6	.NVR 10.-5L
		1.25	5LIR1.25MJ...		0.61	0.9	4.21	7.6	
		1.5	5LIR1.50MJ...		0.73	1.0	4.35	7.7	

Left handed tool supplied by request (Example: 5LIL1.0MJ...).

American Buttress

External

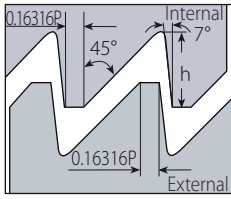

Defined by: ANSI B1.9.1973
Tolerance class: Class 2

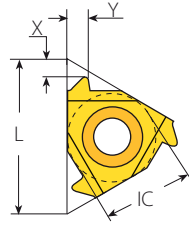

Standard

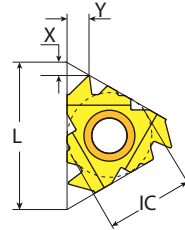

F-Line

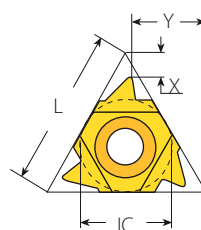

U Style

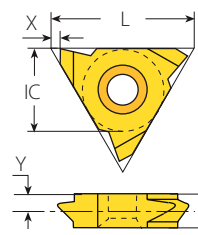

V Style

Standard



Insert Size		Pitch	Ordering Code		Dimensions mm			Anvil		Toolholder
IC	L mm	tpi	RH	LH	h min	X	Y	RH	LH	
1/4"	11	20	2ER20ABUT...	2EL20ABUT...	0.84	1.0	1.4	-	-	NL..-2 (LH)
		16	2ER16ABUT...	2EL16ABUT...	1.05	1.3	1.9	-	-	
3/8"	16	20	3ER20ABUT...	3EL20ABUT...	0.84	1.0	1.4	YE3	YI3	AL..-3 (LH)
		16	3ER16ABUT...	3EL16ABUT...	1.05	1.3	1.9			
		12	3ER12ABUT...	3EL12ABUT...	1.40	1.4	2.0			
		10	3ER10ABUT...	3EL10ABUT...	1.68	1.5	2.3			
1/2"	22	8	4ER8ABUT...	4EL8ABUT...	2.10	2.0	3.2	YE4	YI4	AL..-4 (LH)
		6	4ER6ABUT...	4EL6ABUT...	2.80	2.2	3.5			
1/2"F	23	8	4FER8ABUT...		2.10	2.0	3.2	YE4F		AL...-4F
		6	4FER6ABUT...		2.80	2.2	3.5			

U Style



Insert Size		Pitch	Ordering Code		Dimensions mm			Anvil		Toolholder
IC	L mm	tpi	RH	LH	h min	X	Y	RH	LH	
1/2"U	22	4	4UER4ABUT...	4UEL4ABUT...	4.21	2.4	9.8	YE4U-BUT4	YI4U-BUT4	AL..-4U (LH)
5/8"U	27	3	5UER3ABUT...	5UEL3ABUT...	5.61	3.1	12.1	YE5U-BUT3	YI5U-BUT3	AL..-5U (LH)

V Style



Insert Size		Pitch	Ordering Code		Dimensions mm			Toolholder	
IC	L mm	tpi	RH	LH	h min	X	Y		T
5/8"V	27	4	5VER4ABUT...	5VEL4ABUT...	4.21	0.6	1.8	6	NL..-5V-6 (LH)
		3	5VER3ABUT...	5VEL3ABUT...	5.61	0.6	2.2	8	NL..-5V-8 (LH)
		2.5	5VER2.5ABUT...	5VEL2.5ABUT...	6.73	0.6	2.7	10	NL..-5V-10ABUT (LH)

American Buttress (con't)



External

Defined by: ANSI B1.9.1973
Tolerance class: Class 2

Mega Line

External

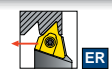

Insert Size	Pitch	Ordering Code	Dimensions mm			Number of Passes		
			IC	L mm	tpi	RH	h min	X
5/8" MG	27	2	5MGER2ABUT...	8.42	1.58	15.55	120	56
		1.5	5MGER1.5ABUT...	11.22	1.64		160	75

External Toolholders for American Buttress



External

Insert	Ordering Code	Dimensions mm				Thread Diameter Range (Min.-Max.)	Spare Parts	
		RH	H=B=H1	F	L1		L2	Insert Screw
5MGER2ABUT...	NL25-5MG2ABUT	25	9.5	150	31	(7"-24")-2ABUT	S5MG	K6T
	NL32-5MG2ABUT	32	16.5	170				
	NL40-5MG2ABUT	40	24.5	200				
5MGER1.5ABUT...	NL25-5MG1.5ABUT	25	9.5	150	31	(11"-24")-1.5ABUT	S5MG	K6T
	NL32-5MG1.5ABUT	32	16.5	170				
	NL40-5MG1.5ABUT	40	24.5	200				

Recommended thread infeed method for Mega Line: Flank or Modified Flank 1°.

American Buttress (con't)

Internal

Defined by: ANSI B1.9.1973
Tolerance class: Class 2

Standard

F-Line

U Style

V Style

Standard



	Insert Size		Pitch	Ordering Code		Dimensions mm			Anvil		Toolholder
	IC	L mm	tpi	RH	LH	h min	X	Y	RH	LH	
	1/4"	11	20	2IR20ABUT...	2IL20ABUT...	0.84	1.0	1.4	-	-	NVR..-2 (LH)
			16	2IR16ABUT...	2IL16ABUT...	1.05	1.3	1.9	-	-	
	3/8"	16	20	3IR20ABUT...	3IL20ABUT...	0.84	1.0	1.4	YI3	YE3	AVR..-3 (LH)
			16	3IR16ABUT...	3IL16ABUT...	1.05	1.3	1.9			
	1/2"	22	12	3IR12ABUT...	3IL12ABUT...	1.40	1.4	2.0	YI4	YE4	AVR..-4 (LH)
			10	3IR10ABUT...	3IL10ABUT...	1.68	1.5	2.3			
	1/2" F	23	8	4FIR8ABUT...		2.10	2.0	3.2	YI4F		AVRC...-4F
			6	4FIR6ABUT...		2.80	2.2	3.5			

U Style

	Insert Size		Pitch	Ordering Code		Dimensions mm			Anvil		Toolholder
	IC	L mm	tpi	RH	LH	h min	X	Y	RH	LH	
	1/2"U	22	4	4UIR4ABUT...	4UIL4ABUT...	4.21	2.4	9.8	YI4U-4B	YE4U-4B	AVR..-4U (LH)
	5/8"U	27	3	5UIR3ABUT...	5UIL3ABUT...	5.61	3.1	12.1	YI5U-3B	YE5U-3B	AVR..-5U (LH)

V Style

	Insert Size		Pitch	Ordering Code		Dimensions mm				Toolholder
	IC	L mm	tpi	RH	LH	h min	X	Y	T	
	5/8"V	27	4	5VIR4ABUT...	5VIL4ABUT...	4.21	0.6	1.8	6	NVR..-5V (LH)
			3	5VIR3ABUT...	5VIL3ABUT...	5.61	0.6	2.2	8	
			2.5	5VIR2.5ABUT...	5VIL2.5ABUT...	6.73	0.6	2.7	10	

American Buttress (con't)



Internal

Defined by: ANSI B1.9.1973
Tolerance class: Class 2

Mega Line

Internal



IC	L mm	Pitch tpi	Ordering Code RH	Dimensions mm			Number of Passes	
				h min	X	Y	0.07mm–Min. Depth of Cut (On radius)	0.15mm–Max. Depth of Cut (On radius)
5/8" MG	27	2	5MGIR2ABUT...	8.94	1.58	15.9	128	60
		1.5	5MGIR1.5ABUT...	11.92	1.64		170	79

Internal Toolholders for American Buttress

Internal

Insert	Ordering Code	Dimensions mm							Min. Bore Dia.	Thread Diameter Range (Min.-Max.)		Spare Parts	
		RH	A	L	L1 (max)	D	D1	F		mm	Short Chip Material	Long Chip Material	Insert Screw
5MGIR2ABUT...	NVRC40-5MG2ABUT	36	230.5	100	40	39.7	35.0	162.6	(7"-16")-2ABUT	(7"-16")-2ABUT	S5MG	K6T	
	NVRC50-5MG2ABUT	46	255.5	125	50	49.7	39.5						
	NVRC60-5MG2ABUT	57	280.5	150	60	59.7	44.0						
5MGIR1.5ABUT...	NVRC40-5MG1.5ABUT	36	230.5	100	40	39.7	35.0	259.1	(11"-22")-1.5ABUT	(11"-22")-1.5ABUT	S5MG	K6T	
	NVRC50-5MG1.5ABUT	46	255.5	125	50	49.7	39.5						
	NVRC60-5MG1.5ABUT	57	280.5	150	60	59.7	44.0						

Recommended thread infeed method for Mega Line: Flank or Modified Flank 1°.

British Buttress

External

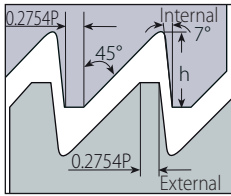

Defined by: B.S. 1657: 1950
Tolerance class: Medium Class

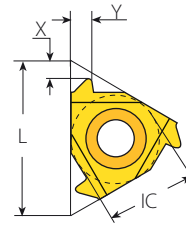

Standard



Standard



Insert Size		Pitch	Ordering Code		Dimensions mm			Anvil		Toolholder
IC	L mm	tpi	RH	LH	h min	X	Y	RH	LH	
3/8"	16	16	3ER16BBUT...	3EL16BBUT...	0.80	1.1	1.6	YE3	YI3	AL..-3 (LH)
		12	3ER12BBUT...	3EL12BBUT...	1.07	1.4	2.1			
		10	3ER10BBUT...	3EL10BBUT...	1.28	1.4	2.2			
		8	3ER8BBUT...	3EL8BBUT...	1.61	1.6	2.5			
1/2"	22	8	4ER8BBUT...	4EL8BBUT...	1.61	1.6	2.5	YE4	YI4	AL..-4 (LH)

British Buttress

Internal

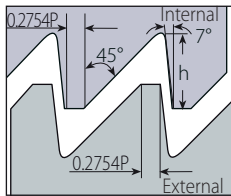

Defined by: B.S. 1657: 1950
Tolerance class: Medium Class

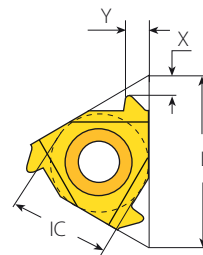

Standard



Standard



Insert Size		Pitch	Ordering Code		Dimensions mm			Anvil		Toolholder
IC	L mm	tpi	RH	LH	h min	X	Y	RH	LH	
3/8"	16	16	3IR16BBUT...	3IL16BBUT...	0.80	1.1	1.6	YI3	YE3	AVR..-3 (LH)
		12	3IR12BBUT...	3IL12BBUT...	1.07	1.4	2.1			
		10	3IR10BBUT...	3IL10BBUT...	1.28	1.4	2.2			
		8	3IR8BBUT...	3IL8BBUT...	1.61	1.6	2.5			
1/2"	22	8	4IR8BBUT...	4IL8BBUT...	1.61	1.6	2.5	YI4	YE4	AVR..-4 (LH)

Metric Buttress (Sägengewinde)

External

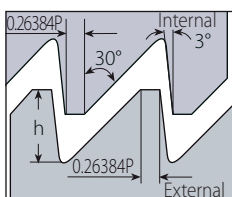

Defined by: DIN 513
Tolerance class: Medium Class

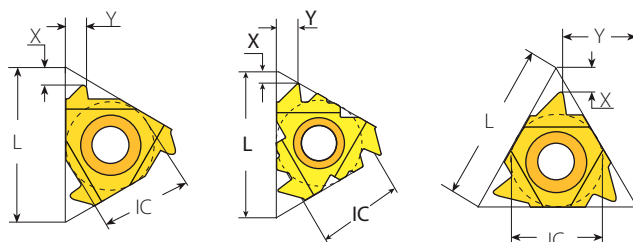

Standard

F-Line

U Style

Standard - External



F.LINE

Insert Size		Pitch	Ordering Code		Dimensions mm			Anvil		Toolholder
IC	L mm	mm	RH	LH	h min	X	Y	RH	LH	
3/8"	16	2.0	3ER2.0SAGE...	3EL2.0SAGE...	1.74	1.5	2.1	YE3	YI3	AL...-3 (LH)
		2.0	4ER2.0SAGE...	4EL2.0SAGE...	1.74	1.5	2.1			
1/2"	22	3.0	4ER3.0SAGE...	4EL3.0SAGE...	2.60	1.8	2.6	YE4	YI4	AL...-4 (LH)
		4.0	4ER4.0SAGE...	4EL4.0SAGE...	3.55	1.75	3.1			
1/2"F	23	3.0	4FER3.0SAGE...		2.60	1.8	2.6	YE4F		AL...-4F
		4.0	4FER4.0SAGE...		3.55	1.75	3.1			
5/8"	27	4.0	5ER4.0SAGE...	5EL4.0SAGE...	3.55	1.9	3.2	YE5 082/038	YI5 082/039	AL...-5 (LH)

U Style - External



Insert Size		Pitch	Ordering Code		Dimensions mm			Anvil		Toolholder
IC	L mm	mm	RH	LH	h min	X	Y	RH	LH	
1/2"U	22	5	4UER5.0SAGE...	4UEL5.0SAGE...	4.41	1.27	10.35	YE4U-SAGE5	YI4U-SAGE5	AL...-4U (LH)
		6	4UER6.0SAGE...	4UEL6.0SAGE...	5.29	1.25	10.28	YE4U-SAGE6	YI4U-SAGE6	

Metric Buttress (Sägengewinde) (con't)

MEGALINE

External

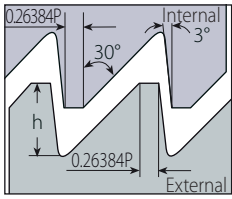

Defined by: DIN 513
Tolerance class: Medium Class

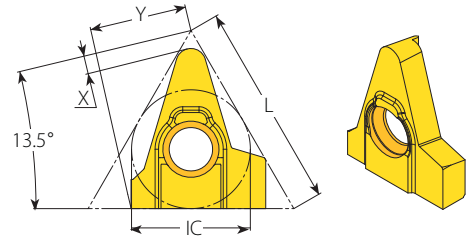

Mega Line

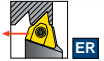

External



Insert Size		Pitch	Ordering Code	Dimensions mm			Number of Passes	
IC	L mm	mm	RH	h min	X	Y	0.07mm–Min. Depth of Cut (On radius)	0.15mm–Max. Depth of Cut (On radius)
5/8" MG	27	10.0	5MGER10.OSAGE...	8.68	1.57	13.3	124	58
		12.0	5MGER12.OSAGE...	10.41	1.81		149	69
		14.0	5MGER14.OSAGE...	12.15	2.05		174	81
		16.0	5MGER16.OSAGE...	13.88	3.27		198	93
		20.0	5MGER20.OSAGE...	17.36	2.56		248	116

Recommended thread infeed method for Mega Line: Flank or Modified Flank 1°.

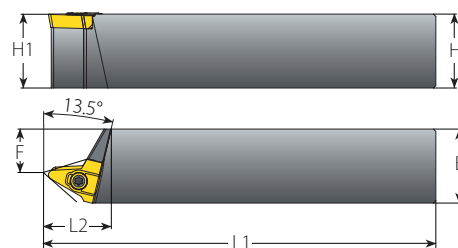
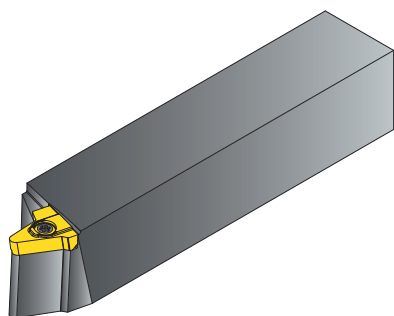
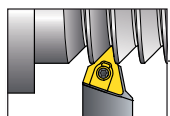

External Toolholders for Metric Buttress (Sägewinde)

MEGALINE



External

Spare Parts

Insert	Ordering Code	Dimensions mm				Thread Diameter Range (Min.-Max.)	 Insert Screw	 Torx Key
		RH	H=B=H1	F	L1			
5MGER10.0SAGE...	NL25-5MG10SAGE	25	11.8	150	30	(S65-80)x10	S5MG	K6T
	NL32-5MG10SAGE	32	18.8	170				
	NL40-5MG10SAGE	40	26.8	200				
5MGER12.0SAGE...	NL25-5MG12SAGE	25	11.8	150	30	(S85-146)x12		
	NL32-5MG12SAGE	32	18.8	170				
	NL40-5MG12SAGE	40	26.8	200				
5MGER14.0SAGE...	NL25-5MG14SAGE	25	11.8	150	30	(S115-145)x14		
	NL32-5MG14SAGE	32	18.8	170				
	NL40-5MG14SAGE	40	26.8	200				
5MGER16.0SAGE...	NL25-5MG16SAGE	25	11.8	150	30	(S150-175)x16		
	NL32-5MG16SAGE	32	18.8	170				
	NL40-5MG16SAGE	40	26.8	200				
5MGER20.0SAGE...	NL25-5MG20SAGE	25	11.8	150	30	(S210-230)x20		
	NL32-5MG20SAGE	32	18.8	170				
	NL40-5MG20SAGE	40	26.8	200				

Recommended thread infeed method for Mega Line: Flank or Modified Flank 1°.

Metric Buttress (Sägengewinde) (con't)

Internal

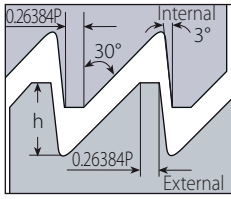

Defined by: DIN 513
Tolerance class: Medium Class

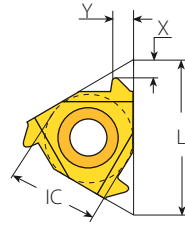

Standard

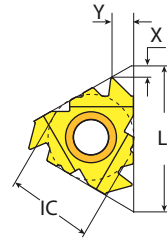

F-line

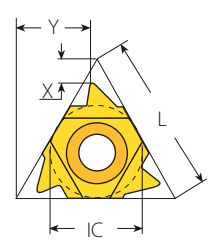

U Style



Standard - Internal



FLINE

Insert Size		Pitch	Ordering Code		Dimensions mm			Anvil		Toolholder
IC	L mm	mm	RH	LH	h min	X	Y	RH	LH	
3/8"	16	2.0	3IR2.0SAGE...	3IL2.0SAGE...	1.50	1.5	2.2	YI3	YE3	AVR..-3 (LH)
1/2"	22	3.0	4IR3.0SAGE...	4IL3.0SAGE...	2.25	1.7	2.9	YI4	YE4	AVR..-4 (LH)
		4.0	4IR4.0SAGE...	4IL4.0SAGE...	3.09	2.03	3.25			
1/2"F	23	3	4FIR3.0SAGE...		2.25	1.7	2.9	YI4F		AVRC...-4F
		4	4FIR4.0SAGE...		3.09	2.03	3.25			
5/8"	27	4.0	5IR4.0SAGE...	5IL4.0SAGE...	3.09	2.1	3.2	YI5 082/039	YE5 082/038	AVR..-5 (LH)

U Style - Internal



Insert Size		Pitch	Ordering Code		Dimensions mm			Anvil		Toolholder
IC	L mm	mm	RH	LH	h min	X	Y	RH	LH	
1/2"U	22	5	4UIR5.0SAGE...	4UIL5.0SAGE...	3.76	1.8	10.3	YI4U-5S	YE4U-5S	AVR..-4U (LH)
		6	4UIR6.0SAGE...	4UIL6.0SAGE...	4.54	1.9	10.15	YI4U-6S	YE4U-6S	

Metric Buttress (Sägewinde) (con't)

MEGA/LINE

Internal

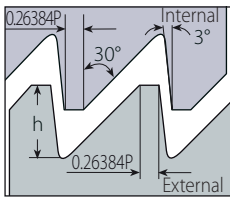
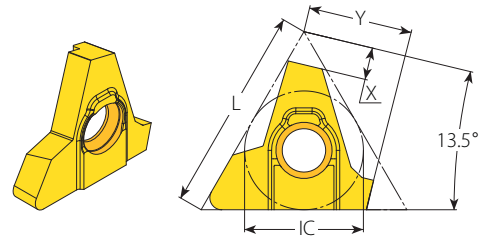

 Defined by: DIN 513
 Tolerance class: Medium Class

Mega Line

Internal

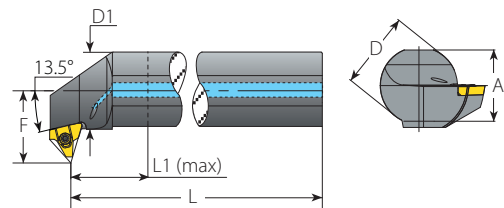
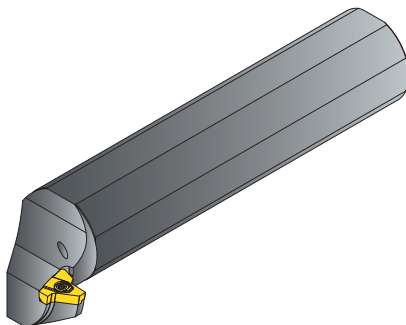
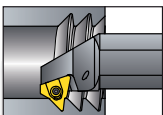

Insert Size	Pitch	Ordering Code	Dimensions mm			Number of Passes	
			IC	L mm	RH	h min	X
5/8" MG	10.0	5MGIR10.0SAGE...	7.21	2.86	13.7	103	48
	12.0	5MGIR12.0SAGE...	8.67	3.34		124	58
	14.0	5MGIR14.0SAGE...	10.12	3.83		145	67
	16.0	5MGIR16.0SAGE...	11.58	4.30		165	77
	20.0	5MGIR20.0SAGE...	14.50	5.16		207	97

Internal Toolholders for Metric Buttress (Sägewinde)

MEGA/LINE

Internal

Spare Parts

Insert	Ordering Code	Dimensions mm							Min. Bore Dia.	Thread Diameter Range (Min.-Max.)		Insert Screw	Torx Key
		RH	A	L	L1 (max)	D	D1	F		mm	Short Chip Material		
5MGIR10.0SAGE...	NVRC40-5MG10SAGE	36	230.5	100	40	39.7	29.0	50	(S65-80)x10	(S75-80)x10	S5MG	K6T	
	NVRC40-5MG12SAGE	36	230.5	100	40	39.7	41.5	67	(S85-400)x12	(S90-400)x12			
5MGIR12.0SAGE...	NVRC50-5MG12SAGE	46	255.5	125	50	49.7	46.5	72	(S90-400)x12	(S105-400)x12			
	NVRC60-5MG12SAGE	57	280.5	150	60	59.7	51.5	82	(S100-400)x12	(S250-400)x12			
5MGIR14.0SAGE...	NVRC40-5MG14SAGE	36	230.5	100	40	39.7	41.5	94	(S115-145)x14	(S115-145)x14			
	NVRC50-5MG14SAGE	46	255.5	125	50	49.7	46.5	94	(S115-145)x14	(S115-145)x14			
	NVRC60-5MG14SAGE	57	280.5	150	60	59.7	51.5	94	(S115-145)x14	(S120-145)x14			
5MGIR16.0SAGE...	NVRC40-5MG16SAGE	36	230.5	100	40	39.7	41.5	126	(S150-175)x16	(S150-175)x16			
	NVRC50-5MG16SAGE	46	255.5	125	50	49.7	46.5	126	(S150-175)x16	(S150-175)x16			
	NVRC60-5MG16SAGE	57	280.5	150	60	59.7	51.5	126	(S150-175)x16	(S150-175)x16			
5MGIR20.0SAGE...	NVRC40-5MG20SAGE	36	230.5	100	40	39.7	41.5	75	(S105-230)x20	(S105-230)x20			
	NVRC50-5MG20SAGE	46	255.5	125	50	49.7	46.5	75	(S105-230)x20	(S210-230)x20			
	NVRC60-5MG20SAGE	57	280.5	150	60	59.7	51.5	80	(S110-230)x20	(S210-230)x20			

Recommended thread infeed method for Mega Line: Flank or Modified Flank 1°.

API

External

Defined by: API SPEC. 7:1990
Tolerance class: Standard API

Standard F-Line On Edge

Standard

Insert Size	Pitch	Thread	Taper	Ordering Code		Size	Dimensions mm			Anvil	Toolholder
				IC	L mm		tpi	IPF	RH		
1/2"	22	4 V-0.038R	2	4ER4API382...	NC23-NC50		3.09	2.1	2.8	YEI 4-API-1P or YE4	AL...-4 5BUT/API or AL...-4
		4 V-0.038R	3	4ER4API383...	NC56-NC77		3.08	2.1	2.8		
		4 V-0.050	2	4ER4API502...	6 5/8" REG, 5 1/2" FH, 6 5/8" FH		3.75	2.0	2.9		
		4 V-0.050	3	4ER4API503...	5 1/2", 7 5/8", 8 5/8" REG		3.74	2.0	2.9		
		5 V-0.040	3	4ER5API403...	2 3/8"-4 1/2" REG		2.99	1.8	2.6		
		6 V-0.055	1.5	4ER6API551...	NC10-NC16		1.41	2.6	2.0		
1/2" F	23	4 V-0.038R	2	4FER4API382...	NC23-NC50		3.09	2.1	2.8	YE4F	AL...-4F
		4 V-0.038R	3	4FER4API383...	NC56-NC77		3.08	2.1	2.8		
		4 V-0.050	2	4FER4API502...	6 5/8" REG, 5 1/2" FH, 6 5/8" FH		3.75	2.0	2.9		
		4 V-0.050	3	4FER4API503...	5 1/2", 7 5/8", 8 5/8" REG		3.74	2.0	2.9		
		5 V-0.040	3	4FER5API403...	2 3/8"-4 1/2" REG		2.99	1.8	2.6		
		6 V-0.055	1.5	4FER6API551...	NC10-NC16		1.41	2.6	2.0		
5/8"	27	4 V-0.038R	2	5ER4API382...	NC23-NC50		3.09	2.1	2.8	YE5OIL	AL...-5 OIL
		4 V-0.038R	3	5ER4API383...	NC56-NC77		3.08	2.1	2.8		
		4 V-0.050	2	5ER4API502...	6 5/8" REG, 5 1/2" FH, 6 5/8" FH		3.75	2.1	3.1		
		4 V-0.050	3	5ER4API503...	5 1/2", 7 5/8", 8 5/8" REG		3.74	2.1	3.1		
		5 V-0.040	3	5ER5API403...	2 3/8"-4 1/2" REG		2.99	1.9	2.7		
		4 V-0.065	2	5ER4API652...	2 3/8" IF- 5 1/2" IF		2.81	2.3	2.8		

On Edge

Insert Size	Pitch	Thread	Taper	Ordering Code		Size	Dimensions mm				Position	
				IC	L mm		tpi	IPF	RH	R	h min	T
5/8"	27	5 V-0.040	3	TNEC54ER5API403...	2 3/8"-4 1/2" REG		0.51	3.00	6.35	6.50	23.4	3.9
		4 V-0.050	2	TNEC55ER4API502...	6 5/8" REG, 5 1/2" FH, 6 5/8" FH		0.64	3.76	7.94			5.0
		4 V-0.050	3	TNEC55ER4API503...	5 1/2", 7 5/8", 8 5/8" REG		0.64	3.76	7.94			5.0
		4 V-0.038	2	TNEC55ER4API382...	NC23-NC50, 2 3/8 - 6 5/8 IF		0.97	3.10	7.94			5.0
		4 V-0.038	3	TNEC55ER4API383...	NC56-NC77		0.97	3.10	7.94			5.0

On Edge inserts are compatible with most commonly used toolholders in the market.

API (con't)

Internal

Defined by: API SPEC. 7:1990
Tolerance class: Standard API

Standard

F-Line

On Edge

Standard



Insert Size		Pitch	Thread	Taper	Ordering Code	Size	Dimensions mm			Anvil	Toolholder
IC	L mm	tpi	IPF	RH			h min	X	Y	RH	
1/2"	22	4	V-0.038R	2	4IR4API382...	NC23-NC50	3.09	2.1	2.8	YEI 4-API-1P or YI4	AVRC...-4 5BUT/API or AVR...-4
		4	V-0.038R	3	4IR4API383...	NC56-NC77	3.08	2.1	2.8		
		4	V-0.050	2	4IR4API502...	6 5/8" REG, 5 1/2" FH, 6 5/8" FH	3.75	2.1	3.1		
		4	V-0.050	3	4IR4API503...	5 1/2", 7 5/8", 8 5/8" REG	3.74	2.0	2.9		
		5	V-0.040	3	4IR5API403...	2 3/8"-4 1/2" REG	2.99	1.8	2.6		
		6	V-0.055	1.5	4IR6API551...	NC10-NC16	1.41	2.6	2.0		
1/2"F	23	4	V-0.038R	2	4FIR4API382...	NC23-NC50	3.09	2.1	2.8	YI4F	AVRC...-4F
		4	V-0.038R	3	4FIR4API383...	NC56-NC77	3.08	2.1	2.8		
		4	V-0.050	2	4FIR4API502...	6 5/8" REG, 5 1/2" FH, 6 5/8" FH	3.75	2.1	3.1		
		4	V-0.050	3	4FIR4API503...	5 1/2", 7 5/8", 8 5/8" REG	3.74	2.0	2.9		
		5	V-0.040	3	4FIR5API403...	2 3/8"-4 1/2" REG	2.99	1.8	2.6		
		6	V-0.055	1.5	4FIR6API551...	NC10-NC16	1.41	2.6	2.0		
5/8"	27	4	V-0.038R	2	5IR4API382...	NC23-NC50	3.09	2.1	2.8	YI5OIL	AVR...-5 OIL
		4	V-0.038R	3	5IR4API383...	NC56-NC77	3.08	2.1	2.8		
		4	V-0.050	2	5IR4API502...	6 5/8" REG, 5 1/2" FH, 6 5/8" FH	3.75	2.1	3.1		
		4	V-0.050	3	5IR4API503...	5 1/2", 7 5/8", 8 5/8" REG	3.74	2.1	3.1		
		5	V-0.040	3	5IR5API403...	2 3/8"-4 1/2" REG	2.99	1.9	2.7		
		4	V-0.065	2	5IR4API652...	2 3/8" IF- 5 1/2" IF	2.81	2.3	2.8		

On Edge



Insert Size		Pitch	Thread	Taper	Ordering Code	Size	Dimensions mm				Position	
IC	L mm	tpi	IPF	RH			R	h min	T	ØC	X	Y
5/8"	27	5	V-0.040	3	TNEC54IR5API403...	2 3/8"-4 1/2" REG	0.51	3.00	6.35	6.50	23.4	3.9
		4	V-0.050	2	TNEC55IR4API502...	6 5/8" REG, 5 1/2" FH, 6 5/8" FH	0.64	3.76	7.94			5.0
		4	V-0.050	3	TNEC55IR4API503...	5 1/2", 7 5/8", 8 5/8" REG	0.64	3.76	7.94			5.0
		4	V-0.038	2	TNEC55IR4API382...	NC23-NC50, 2 3/8 - 6 5/8 IF	0.97	3.10	7.94			5.0
		4	V-0.038	3	TNEC55IR4API383...	NC56-NC77	0.97	3.10	7.94			5.0

On Edge inserts are compatible with most commonly used toolholders in the market.

API Buttress Casing

External

Defined by: STD.5B.1979
Tolerance class: Standard API

Standard **F-Line** **M+ Style** **T+ Style** **14D**
2 Cutting Edges



Standard



F LINE

Insert Size	Pitch	Taper	Ordering Code	Size	Dimensions mm			Anvil	
					IC	L mm	tpi	IPF	RH
1/2"	22	5	4ER5BUT75...	4 1/2"-13 3/8"	1.55	3.1	1.9	YEI 4-BUT or YE4	AL...-4 5BUT/API or AL...-4
			4ER5BUT1...	16"-20"					
1/2"F	23	5	4FER5BUT75...	4 1/2"-13 3/8"	1.57	3.1	1.9	YE4F	AL...-4F
			4FER5BUT1...	16"-20"					

M+ Style

Multi+



Insert Size	Pitch	Taper	Teeth	Ordering Code	Size	Dimensions mm			Anvil		
						IC	L mm	tpi	IPF	RH	Toolholder
5/8"	27	5	0.75	2	5ER5BUT752M+...	4 1/2"-13 3/8"	1.55	4.8	6.8	YE5M	AL...-5M

T+ Style

Multi+



Insert Size	Pitch	Taper	Teeth	Ordering Code	Size	Dimensions mm			Anvil		
						IC	L mm	tpi	IPF	RH	Toolholder
1/2"T	22	5	0.75	3	4ER5BUT753T+...	4 1/2"-13 3/8"	1.55	2.5	16.1	Y4T	AL...-4T
			1		4ER5BUT13T+...	16"-20"					

14D

Multi+



Insert Size	Pitch	Taper	Teeth	Ordering Code	Size	Dimensions mm		Anvil		
						IC	tpi	IPF	RH	Toolholder
14D	5	0.75	2	14DER5BUT752T+	4 1/2"-9 5/8"	1.55	10.0	Y14DER-5 BUT	AL...-14D	
					10 3/4"-13 3/8"					Y14DER-5BUT-0.4N
					16"-20"					Y14DER-5BUT-0.4N

API Buttress Casing (con't)

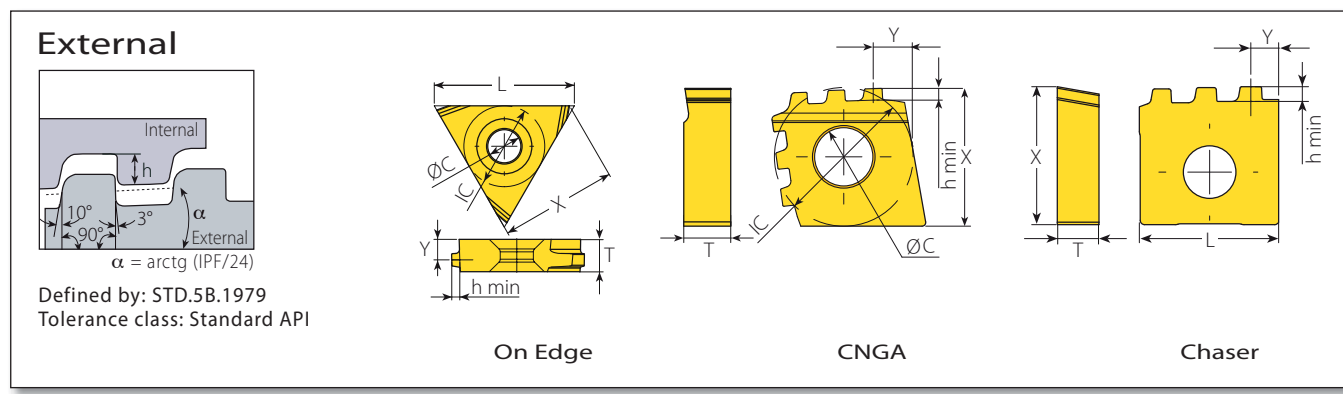

On Edge



Insert Size		Pitch	Taper	Ordering Code	Size	Dimensions mm			Position	
IC	L mm	tpi	IPF	RH		h min	T	Ø C	X	Y
5/8"	27	5	0.75	TNEC54ER5BUT75...	4 1/2"-13 3/8"	1.55	6.35	6.5	23.4	4.0
		5	1	TNEC54ER5BUT1...	16"-20"					

On Edge inserts are compatible with most commonly used toolholders in the market.

CNGA



Insert Size		Pitch	Taper	Teeth	Ordering Code	Size	Dimensions mm			Position	
IC	tpi	IPF		RH		h min	T	Ø C	X	Y	
3/4"		5	0.75	3	CNGA64ER5BUT75T3...	4 1/2"-13 3/8"	1.55	6.35	8.0	18.9	5.6
		5	1	3	CNGA64ER5BUT1T3...	16"-20"					5.5

CNGA inserts are compatible with most commonly used toolholders in the market.

Chaser



Insert Size		Pitch	Taper	Teeth	Ordering Code	Size	Dimensions mm			Position	
L	tpi	IPF		RH		h min	T	X	Y		
16		5	0.75	3	1616ER5BUT753S+...	4 1/2"-13 3/8"	1.55	4.76	15.7	3.2	
		5	1	3	1616ER5BUT13S+...	16"-20"					

Chaser inserts are compatible with most commonly used toolholders in the market.

API Buttress Casing (con't)

Internal

Defined by: STD.5B:1979
Tolerance class: Standard API

Standard

F-Line M+

M+ Style

T+ Style

14D
2 Cutting Edges



Standard



FLINE

Insert Size		Pitch	Taper	Ordering Code	Size	Dimensions mm			Anvil	Toolholder
IC	L mm	tpi	IPF	RH		h min	X	Y	RH	
1/2"	22	5	0.75	4IR5BUT75...	4 1/2"-13 3/8"	1.55	2.8	1.9	YEI 4-BUT or YI4	AVRC...-4 5BUT/API or AVR...-4
		5	1	4IR5BUT1...	16"-20"	1.55	2.8	1.9		
1/2"F	23	5	0.75	4FIR5BUT75...	4 1/2"-13 3/8"	1.57	2.8	1.9	YI4F	AVRC...-4F
		5	1	4FIR5BUT1...	16"-20"	1.57	2.8	1.9		

M+ Style

Multiplus



Insert Size		Pitch	Taper	Teeth	Ordering Code	Size	Dimensions mm			Anvil	Toolholder
IC	L mm	tpi	IPF		RH		h min	X	Y	RH	
5/8"	27	5	0.75	2	5IR5BUT752M+...	4 1/2"-13 3/8"	1.55	4.8	6.7	YI5M	AVR...-5M

T+ Style

Multiplus



Insert Size		Pitch	Taper	Teeth	Ordering Code	Size	Dimensions mm			Anvil	Toolholder
IC	L mm	tpi	IPF		RH		h min	X	Y	RH	
1/2"T	22	5	0.75	3	4IR5BUT753T+...	4 1/2"-13 3/8"	1.55	2.5	16.1	Y4T	AVR...-4T
			1		4IR5BUT13T+...	16"-20"					

14D

Multiplus



Insert Size		Pitch	Taper	Teeth	Ordering Code	Size	Dimensions mm			Anvil	Toolholder
IC		tpi	IPF		RH		h min	Y		RH	
14D		5	0.75	2	14DIR5BUT752T+...	4 1/2"-9 5/8"	1.55	10.0		Y14DIR-5 BUT	AVRC...-14D
			1		14DIR5BUT12T+...	16"-20"				Y14DIR-5BUT-0.4N	
		5	1	2	14DIR5BUT12T+...	16"-20"	1.55	10.0	Y14DIR-5BUT-0.4N	AVRC...-14D	

API Buttress Casing (con't)

Internal

Defined by: STD.5B:1979
Tolerance class: Standard API

On Edge



Insert Size		Pitch	Taper	Ordering Code	Size	Dimensions mm			Position	
IC	L mm	tpi	IPF	RH		h min	T	Ø C	X	Y
5/8"	22	5	0.75	TNEC54IR5BUT75...	4 1/2"-13 3/8"	1.55	6.35	6.5	23.4	4.3
		5	1	TNEC54IR5BUT1...	16"-20"					

On Edge inserts are compatible with most commonly used toolholders in the market.

CNGA



Insert Size		Pitch	Taper	Teeth	Ordering Code	Size	Dimensions mm			Position	
IC	tpi	IPF		RH		h min	T	Ø C	X	Y	
3/4"	5	0.75	3	CNGA64IR5BUT75T3...	4 1/2"-13 3/8"	1.55	6.35	8.0	18.9	5.6	
	5	0.75	2	CNGA64IR5BUT75T2...	4 1/2"-13 3/8"					10.4	
	5	1	3	CNGA64IR5BUT1T3...	16"-20"					5.5	

CNGA inserts are compatible with most commonly used toolholders in the market.

Chaser



Insert Size		Pitch	Taper	Teeth	Ordering Code	Size	Dimensions mm			Position	
L	tpi	IPF		RH		h min	T	X	Y		
16	5	0.75	3	1616IR5BUT753S+...	4 1/2"-13 3/8"	1.55	4.76	15.7	3.2		
	5	1	3	1616IR5BUT13S+...	16"-20"						

Chaser inserts are compatible with most commonly used toolholders in the market.

API Round Casing & Tubing

External

Defined by: API STD. 5B:1979
Tolerance class: Standard API RD

Standard

SCB Sintered Chipbreaker

M+ Style

F-Line M+

Z+ Style

Standard



Insert Size		Pitch	Ordering Code	Dimensions mm			Anvil	
IC	L mm	tpi	RH	h min	X	Y	RH	Toolholder
3/8"	16	10	3ER10APIRD...	1.41	1.2	1.4	YEI3-APIRD or YE3	AL...-3 APIRD or AL...-3
		8	3ER8APIRD...	1.81	1.3	1.5		
3/8" SCB	16	10	3JER10APIRD...	1.41	1.2	1.5		
		8	3JER8APIRD...	1.81	1.3	1.5		

M+ Style



Insert Size		Pitch	Teeth	Ordering Code	Dimensions mm			Anvil	
IC	L mm	tpi		RH	h min	X	Y	RH	Toolholder
1/2"	22	10	2	4ER10APIRD2M+...	1.41	2.3	3.8	YE4M	AL...-4
1/2"F	23	10	2	4FER10APIRD2M+...	1.41	2.3	3.8	YE4M2F	AL...-4MF
5/8"	27	10	3	5ER10APIRD3M+...	1.41	3.9	6.3	YE5M	AL...-5M
		8	2	5ER8APIRD2M+...	1.81	2.9	4.5		

Z+ Style



Insert Size		Pitch	Teeth	Ordering Code	Dimensions mm			Anvil	
IC	L mm	tpi		RH	h min	X	Y	RH	Toolholder
1/2"	22	10	2	4ER10APIRD2Z+...	1.41	3.0	9.9	YE4Z	AL...-4Z
		8	2	4ER8APIRD2Z+...	1.81	3.7	9.6		

API Round Casing & Tubing (con't)

External

Defined by: API STD. 5B:1979
Tolerance class: Standard API RD

T+ Style

**14D -
2 Cutting Edges**

T+ Style



Insert Size		Pitch	Teeth	Ordering Code	Dimensions mm			Anvil	
IC	L mm	tpi		RH	h min	X	Y	RH	Toolholder
1/2" T	22	10	6	4ER10APIRD6T+...	1.41	0.2	16.2		
		8	3	4ER8APIRD3T+...	1.81	0.2	14.2	Y4T	AL...-4T
		8	5	4ER8APIRD5T+...	1.81	0.2	16.7		

14D



Insert Size		Pitch	Teeth	Ordering Code	Size	Dimensions mm		Anvil	
IC	tpi			RH		h min	Y	RH	Toolholder
14D	10	4		14DER10APIRD4T+...	2 3/8" and up	1.41	8.7	Y14DER-10 APIRD	
	10	3		14DER10APIRD3T+...	2 3/8" and up		8.8	Y14DER-10 APIRD-3+ AL...-14D	
	8	3		14DER8APIRD3T+...	2 3/8" and up	1.81	8.1	Y14DER-8 APIRD	

API Round Casing & Tubing (con't)

External

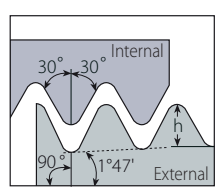

Defined by: API STD. 5B:1979
Tolerance class: Standard API RD

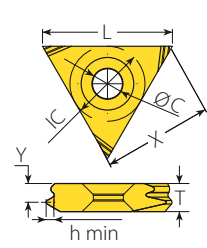

On Edge

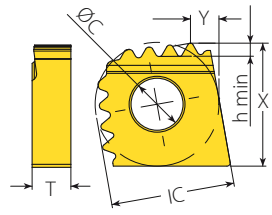

CNGA

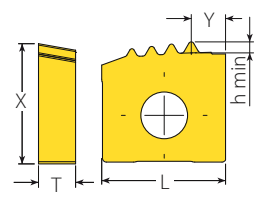

Chaser

On Edge



Insert Size		Pitch	Ordering Code	Dimensions mm			Position	
IC	L mm	tpi	RH	h min	T	Ø C	X	Y
1/2"	22	10	TNEC43ER10APIRD...	1.41	4.76	5.2	18.6	3.2
		8	TNEC43ER8APIRD...	1.81				

On Edge inserts are compatible with most commonly used toolholders in the market.

CNGA



Insert Size		Pitch	Teeth	Ordering Code	Dimensions mm			Position	
IC	tpi		RH	h min	T	Ø C	X	Y	
3/4"	10	5	CNGA64ER10APIRDT5...	1.41	6.35	8.0	18.9	4.5	
	8	4	CNGA64ER8APIRDT4...	1.81					

CNGA inserts are compatible with most commonly used toolholders in the market.

Chaser



Insert Size		Pitch	Teeth	Ordering Code	Dimensions mm			Position	
L	tpi		RH	h min	T	X	Y		
16	10	4	1616ER10APIRD4S+...	1.41	4.76	15.4	4.4		
	8	3	1616ER8APIRD3S+...	1.81		15.9			

Chaser inserts are compatible with most commonly used toolholders in the market.

API Round Casing & Tubing (con't)

Internal

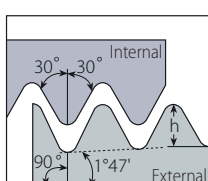

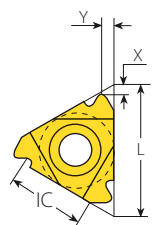

Standard

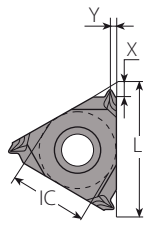

**SCB
Sintered
Chipbreaker**

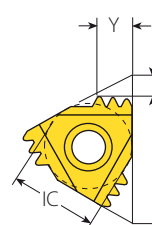

M+ Style

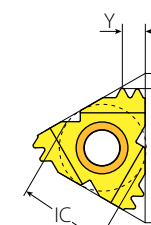

F-Line M+

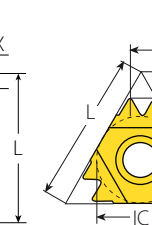

Z+ Style

Defined by: API STD. 5B:1979
Tolerance class: Standard
API RD

Standard



Insert Size		Pitch	Ordering Code	Dimensions mm			Anvil	
IC	L mm	tpi	RH	h min	X	Y	RH	Toolholder
3/8"	16	10	3IR10APIRD...	1.41	1.2	1.4	YEI3-APIRD or YI3	AVRC... 3APIRD or AVRC...-3
		8	3IR8APIRD...	1.81	1.3	1.5		
3/8" SCB	16	10	3JIR10APIRD...	1.41	1.2	1.5		
		8	3JIR8APIRD...	1.81	1.3	1.5		

M+ Style



Insert Size		Pitch	Teeth	Ordering Code	Dimensions mm			Anvil	
IC	L mm	tpi		RH	h min	X	Y	RH	Toolholder
1/2"	22	10	2	4IR10APIRD2M+...	1.41	2.4	3.7	YI4M	AVR...-4
		8	2	4IR8APIRD2M+...	1.81	2.9	4.5		
1/2"F	23	10	2	4FIR10APIRD2M+...	1.41	2.4	3.7		
5/8"	27	10	3	5IR10APIRD3M+...	1.41	3.9	6.3		
		8	2	5IR8APIRD2M+...	1.81	2.9	4.5		

Z+ Style



Insert Size		Pitch	Teeth	Ordering Code	Dimensions mm			Anvil	
IC	L mm	tpi		RH	h min	X	Y	RH	Toolholder
1/2"	22	10	2	4IR10APIRD2Z+...	1.41	3.0	9.9	YI4Z	AVR...-4Z
		8	2	4IR8APIRD2Z+...	1.81	3.7	9.6		

API Round Casing & Tubing (con't)

Internal

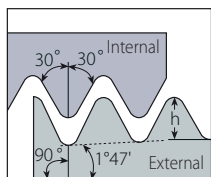

Defined by: STD. 5B:1979
Tolerance class: Standard API RD

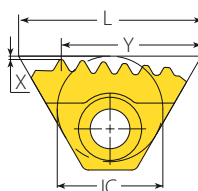

Z+ Style

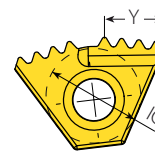

14D -
2 Cutting Edges

T+ Style



Insert Size	Pitch	Teeth	Ordering Code	Dimensions mm	Anvil				
IC	L mm	tpi	RH	h min	X	Y	RH	Toolholder	
1/2" T	22	10	6	4IR10APIRD6T+...	1.41	0.2	16.8		
		8	3	4IR8APIRD3T+...	1.81	0.2	14.2	Y4T	AVR...-4T
		8	5	4IR8APIRD5T+...	1.81	0.2	16.7		

14D



Insert Size	Pitch	Teeth	Ordering Code	Size	Dimensions mm	Anvil		
IC	tpi				h min	Y	Toolholder	
14D	10	4	14DIR10APIRD4T+...	2 3/8" and up	1.41	8.71	Y14DIR-10 APIRD	
	10	3	14DIR10APIRD3T+...	2 3/8" and up	1.81	8.79	Y14DIR-10 APIRD-3+	AVRC...-14D
	8	3	14DIR8APIRD3T+...	2 3/8" and up	1.81	8.10	Y14DIR-8 APIRD	

API Round Casing & Tubing (con't)

Internal

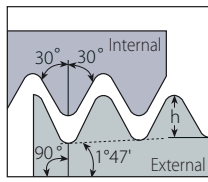

Defined by: STD. 5B:1979
Tolerance class: Standard API RD

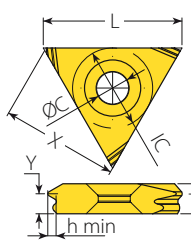

On Edge

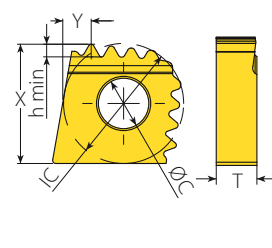

CNGA

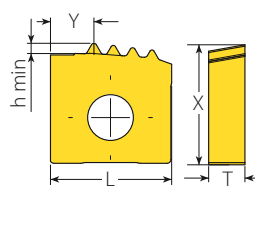

Chaser

On Edge



Insert Size		Pitch	Ordering Code	Dimensions mm			Position	
IC	L mm	tpi	RH	h min	T	Ø C	X	Y
1/2"	22	10	TNEC43IR10APIRD...	1.41	4.76	5.2	18.6	3.2
		8	TNEC43IR8APIRD...	1.81				

On Edge inserts are compatible with most commonly used toolholders in the market.

CNGA



Insert Size		Pitch	Teeth	Ordering Code	Dimensions mm			Position	
IC	tpi		RH	h min	T	Ø C	X	Y	
3/4"	10	5	CNGA64IR10APIRDT5...	1.41	6.35	8.0	18.9	4.5	
	8	4	CNGA64IR8APIRDT4...	1.81					

CNGA inserts are compatible with most commonly used toolholders in the market.

Chaser

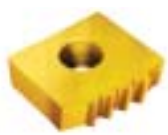

Insert Size		Pitch	Teeth	Ordering Code	Dimensions mm			Position	
L	tpi		RH	h min	T	X	Y		
16	10	4	1616IR10APIRD4S+...	1.41	4.76	15.4	5.7		
	8	3	1616IR8APIRD3S+...	1.81				15.9	4.4

Chaser inserts are compatible with most commonly used toolholders in the market.

VAM

External

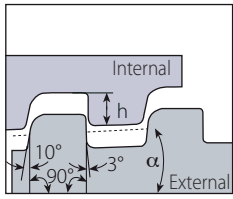

Defined by: VAM
Tolerance class: Standard VAM

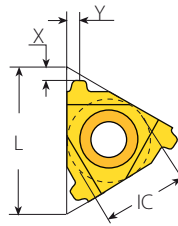

Standard

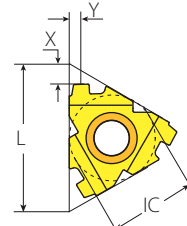

F-Line

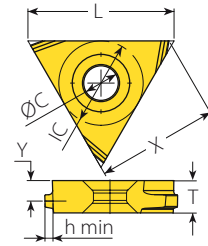

On Edge

Standard



FLINE

Insert Size		Pitch	Taper	Ordering Code	Size	Dimensions mm			Anvil	
IC	L mm	tpi	IPF	RH		h min	X	Y	RH	Toolholder
3/8"	16	8	0.75	3ER8VAM...	2 3/8", 2 7/8"	0.97	1.7	1.8	YE3	AL...-3
1/2"	22	6		4ER6VAM...	3 1/2"	0.97	2.4	2.4	YE4	AL...-4
		5		4ER5VAM...	5"-9 5/8"	1.55	2.4	2.7		
1/2"F	23	6		4FER6VAM...	3 1/2"	0.97	2.4	2.4	YE4F	AL...-4F
		5	4FER5VAM...	5"-9 5/8"	1.55	2.4	2.7			

On Edge



Insert Size		Pitch	Taper	Ordering Code	Size	Dimensions mm			Position	
IC	L mm	tpi	IPF	RH		h min	T	Ø C	X	Y
1/2"	22	8	0.75	TNEC43ER8VAM...	2 3/8", 2 7/8"	0.97	4.76	5.2	18.6	3.3
		6		TNEC43ER6VAM...	3 1/2"	0.97	4.76			2.9
5/8"	27	5		TNEC54ER5VAM...	5"-9 5/8"	1.55	6.35	6.5	23.4	4.0

On Edge inserts are compatible with most commonly used toolholders in the market.

VAM (con't)

Internal

Defined by: VAM
Tolerance class: Standard VAM

Standard

F-Line

On Edge

CNGA

Standard



FLINE

Insert Size		Pitch	Taper	Ordering Code	Size	Dimensions mm			Anvil	
IC	L mm	t _{pi}	IPF	RH		h min	X	Y	RH	Toolholder
3/8"	16	8	0.75	3IR8VAM...	2 3/8", 2 7/8"	1.02	1.7	1.8	YI3	AVR...-3
		6		4IR6VAM...	3 1/2"	1.02	2.5	2.5	YI4	AVR...-4
1/2"	22	5	0.75	4IR5VAM...	5"-9 5/8"	1.55	2.4	2.5	YI4F	AVRC...-4F
		6		4FIR6VAM...	3 1/2"	1.02	2.5	2.5		
1/2"F	23	5		4FIR5VAM...	5"-9 5/8"	1.55	2.4	2.5		

On Edge



Insert Size		Pitch	Taper	Ordering Code	Size	Dimensions mm			Position	
IC	L mm	t _{pi}	IPF	RH		h min	T	ØC	X	Y
1/2"	22	8	0.75	TNEC43IR8VAM...	2 3/8", 2 7/8"	1.02	4.78	5.2	18.6	3.2
		6		TNEC43IR6VAM...	3 1/2"	1.02	4.78			3.1
5/8"	27	5		TNEC54IR5VAM...	5"-9 5/8"	1.55	6.35	6.5	23.4	4.2

On Edge inserts are compatible with most commonly used toolholders in the market.

CNGA

Multiplus



Insert Size		Pitch	Taper	Teeth	Ordering Code	Size	Dimensions mm			Position	
IC	t _{pi}	IPF			RH		h min	T	ØC	X	Y
3/4"	5	3/4		2	CNGA64IR5VAM75T2...	5"-9 5/8"	1.55	6.35	8.0	18.9	9.3

CNGA inserts are compatible with most commonly used toolholders in the market.

New VAM

External

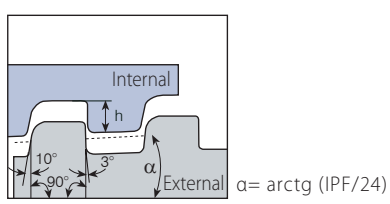

Defined by: VAM
Tolerance class: Standard VAM

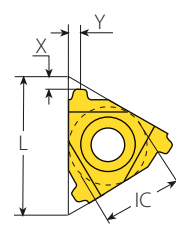

Standard

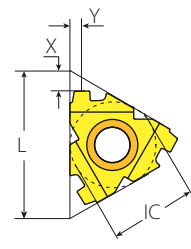

F-Line

Standard



FLINE

Insert Size		Pitch	Taper	Ordering Code	Size	Dimensions mm			Anvil	
IC	L mm	tpi	IPF	RH		h min	X	Y	RH	Toolholder
3/8"	16	8	0.75	3ER8NVAM...	2 3/8", 2 7/8"	0.97	1.8	1.8	YE3	AL...-3
		6		4ER6NVAM...	3 1/2"	0.97	2.3	2.3	YE4	AL...-4
1/2"	22	5	0.75	4ER5NVAM...	5"-9 5/8"	1.55	2.3	2.3	YE4F	AL...-4F
		6		4FER6NVAM...	3 1/2"	0.97	2.2	2.1		
1/2"	23	5		4FER5NVAM...	5"-9 5/8"	1.55	2.5	2.3		

New VAM (con't)

Internal

Defined by: VAM
Tolerance class: Standard VAM

Standard
F-Line
On Edge
CNGA

Standard



FLINE

Insert Size	Pitch	Taper	Ordering Code	Size	Dimensions mm			Anvil	Toolholder
					IC	L mm	h min		
3/8"	16	8	3IR8NVAM...	2 3/8", 2 7/8"	1.23	1.8	1.8	Y13	AVR...-3
1/2"	22	6	4IR6NVAM...	3 1/2"	1.23	2.5	2.5	Y14	AVR...-4
1/2"	23	6	4FIR6NVAM...	3 1/2"	1.23	2.0	1.8	Y14F	AVRC...-4F
			4FIR5NVAM...	5"-9 5/8"	1.77	2.1	2.1		

On Edge



Insert Size	Pitch	Taper	Ordering Code	Size	Dimensions mm					
					IC	L mm	h min	T	ØC	X
1/2"	22	8	TNEC43IR8NVAM...	2 3/8" - 2 7/8"	1.23	4.76	5.2	18.6	3.2	3.1
5/8"	27	5	TNEC54IR5NVAM...	5"-16"	1.77	6.35	6.5	23.4	4.2	

On Edge inserts are compatible with most commonly used toolholders in the market.

CNGA

Multiplus



Insert Size	Pitch	Taper	Teeth	Ordering Code	Size	Dimensions mm			Position	
						IC	tpi	IPF	h min	T
3/4"	6	0.75	2	CNGA64IR6NVAM75T2...	3 1/2" - 4 1/2"	1.23	6.35	8	18.9	9.3
				CNGA64IR5NVAM75T2...	5"-16"	1.77	6.35			

CNGA inserts are compatible with most commonly used toolholders in the market.

EL-Extreme Line

External / Internal

Defined by: API STD,5B:1979
Tolerance class: Standard

Standard External

Standard Internal

On Edge External

On Edge Internal

Standard - External



Insert Size		Pitch	Taper	Ordering Code	Size	Dimensions mm			Anvil	
IC	L mm	tpi	IPF	RH		h min	X	Y	RH	Toolholder
1/2"	22	6	1.5	4ER6EL15...	5"-7 5/8"	1.21	1.9	1.9	YE4	AL..-4
		5	1.25	4ER5EL125...	8 5/8"-10 3/4"	1.71	2.3	2.4		

On Edge - External



Insert Size		Pitch	Taper	Ordering Code	Size	Dimensions mm			Position	
IC	L mm	tpi	IPF	RH		h min	T	ØC	X	Y
5/8"	27	6	1.5	TNEC54ER6EL15...	5"-7 5/8"	1.21	6.35	6.5	23.4	4.8
		5	1.25	TNEC54ER5EL125...	8 5/8"-10 3/4"	1.71	6.35			4.3

On inserts are compatible with most commonly used toolholders in the market.

Standard - Internal



Insert Size		Pitch	Taper	Ordering Code	Size	Dimensions mm			Anvil	
IC	L mm	tpi	IPF	RH		h min	X	Y	RH	Toolholder
1/2"	22	6	1.5	4IR6EL15...	5"-7 5/8"	1.39	1.8	1.9	Y14	AVR..-4
		5	1.25	4IR5EL125...	8 5/8"-10 3/4"	1.91	2.2	2.4		

On Edge - Internal



Insert Size		Pitch	Taper	Ordering Code	Size	Dimensions mm			Position	
IC	L mm	tpi	IPF	RH		h min	T	ØC	X	Y
5/8"	27	6	1.5	TNEC54IR6EL15...	5"-7 5/8"	1.39	6.35	6.5	23.4	4.8
		5	1.25	TNEC54IR5EL125...	8 5/8"-10 3/4"	1.91	6.35			4.3

On Edge inserts are compatible with most commonly used toolholders in the market.

Hughes H-90

External / Internal

Defined by: API STD,5B:1979
Tolerance class: Standard

U Style - External



Insert Size	Pitch	Taper	Ordering Code	Size	Dimensions mm			Anvil		
					IC	L mm	tpi	IPF	RH	Toolholder
1/2" U	22	3.5	2	4UER3.5H902...	3 1/2"-6 5/8"	2.50	4.2	11	YE4U-H90	AL...-4U
5/8" U	27	3.5	3	4UER3.5H903...	7"-8 5/8"	2.50	4.2	11	YE5U-H90	AL...-5UH90
		3	1.25*	5UER3H90SL...	2 3/8"-3 1/2"	2.24	5.5	13.7		

On Edge - External



Insert Size	Pitch	Taper	Ordering Code	Size	Dimensions mm			Position			
					IC	L mm	tpi	IPF	RH	h min	T
5/8"	27	3.5	2	TNEC55ER3.5H902...	3 1/2"-6 5/8"	2.50	7.93	6.5	23.4	4.3	
		3.5	3	TNEC55ER3.5H903...	7"-8 5/8"	2.50	7.93				4.3
		3	1.25*	TNEC56ER3H90SL...	2 3/8"-3 1/2"	2.24	9.53				5.7

On Edge inserts are compatible with most commonly used toolholders in the market.

U Style - Internal



Insert Size	Pitch	Taper	Ordering Code	Size	Dimensions mm			Anvil		
					IC	L mm	tpi	IPF	RH	Toolholder
1/2" U	22	3.5	2	4UIR3.5H902...	3 1/2"-6 5/8"	2.50	4.2	11	YI4U-H90	AVR...-4U
5/8" U	27	3.5	3	4UIR3.5H903...	7"-8 5/8"	2.50	4.2	11	YI5U-H90	AVR...-5UH90
		3	1.25*	5UIR3H90SL...	2 3/8"-3 1/2"	2.24	5.5	13.7		

On Edge - Internal



Insert Size	Pitch	Taper	Ordering Code	Size	Dimensions mm			Position			
					IC	L mm	tpi	IPF	RH	h min	T
5/8"	27	3.5	2	TNEC55IR3.5H902...	3 1/2"-6 5/8"	2.49	7.93	6.5	23.4	4.3	
		3.5	3	TNEC55IR3.5H903...	7"-8 5/8"	2.49	7.93				4.3
		3	1.25*	TNEC56IR3H90SL...	2 3/8"-3 1/2"	2.24	9.53				5.7

On Edge inserts are compatible with most commonly used toolholders in the market.

* H-90 Slimline.

Pg

External / Internal

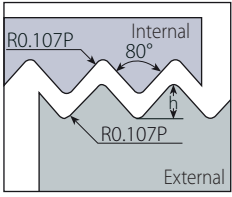

Defined by: DIN 40430
Tolerance class: Standard

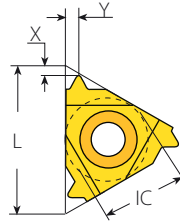

Standard External

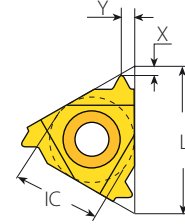

Standard Internal

Standard - External



Insert Size		Pitch	Thread	Ordering Code		Dimensions mm			Anvil		Toolholder
IC	L mm	tpi		RH	LH	h min	X	Y	RH	LH	
1/4"	11	20	Pg7	2ER20PG...	2EL20PG...	0.61	0.8	0.9	-	-	NL..-2 (LH)
		18	Pg9/11/13.5/16	2ER18PG...	2EL18PG...	0.67	0.8	1.0	-	-	
		16	Pg21/29/36/42/48	2ER16PG...	2EL16PG...	0.76	0.9	1.1	-	-	
3/8"	16	20	Pg7	3ER20PG...	3EL20PG...	0.61	0.8	0.9	YE3	YI3	AL..-3 (LH)
		18	Pg9/11/13.5/16	3ER18PG...	3EL18PG...	0.67	0.8	1.0			
		16	Pg21/29/36/42/48	3ER16PG...	3EL16PG...	0.76	0.9	1.1			

Standard - Internal



Insert Size		Pitch	Thread	Ordering Code		Dimensions mm			Anvil		Toolholder
IC	L mm	tpi		RH	LH	h min	X	Y	RH	LH	
1/4"	11	20	Pg7	2IR20PG...	2IL20PG...	0.64	0.8	0.9	-	-	NVR..-2 (LH)
		18	Pg9/11/13.5/16	2IR18PG...	2IL18PG...	0.67	0.8	1.0			
		16	Pg21/29/36/42/48	2IR16PG...	2IL16PG...	0.76	0.9	1.1			
3/8"	16	20	Pg7	3IR20PG...	3IL20PG...	0.64	0.8	0.9	YI3	YE3	AVR..-3 (LH)
		18	Pg11/13.5/16	3IR18PG...	3IL18PG...	0.67	0.8	1.0			
		16	Pg21/29/36/42/48	3IR16PG...	3IL16PG...	0.76	0.8	1.1			

Pg (con't)

Internal

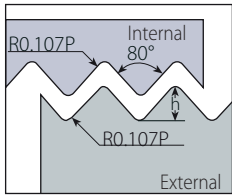

Defined by: DIN 40430
Tolerance class: Standard

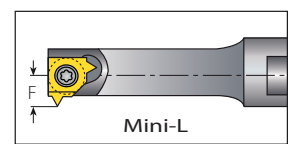
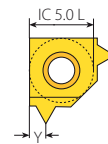
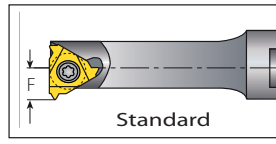
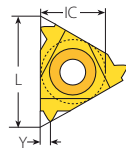

Mini-3 Standard



Insert Size		Pitch	Thread	Ordering Code		Dimensions mm			Min. Bore Dia.	
IC mm	L mm	tpi		RH	LH	h min	Y	F	mm	Toolholder
5.0	8	20	Pg7	5.0KIR20PG...		0.61	0.7	4.7	7.8	(C)NVRC7-5.0K (LH)
6.0	10	20	Pg7	6.0IR20PG...		0.61	0.8	5.3	10.0	.NVR1..-6.0
		18	Pg9/11/13.5/16	6.0IR18PG...		0.67	0.9	5.3		

Left handed tool supplied by request (Example: 5LIL1.0MJ...).

Mini-L



Insert Size		Pitch	Thread	Ordering Code		Dimensions mm			Min. Bore Dia.	
IC mm		tpi		RH	LH	h min	Y	F	mm	Toolholder
5.0L		20	Pg7	5LIR20PG...		0.61	0.8	4.65	8.0	.NVR10..-5
		18	Pg9/11/13.5/16	5LIR18PG...		0.67	0.9	4.65		

Left handed tool supplied by request (Example: 5LIL20PG...).



Thread Turning Toolholders

Vardex Ordering Code System

External Toolholders

A	L	32	-	4	U	C	7	8	9
1	2	3		4	5	6			

1 - Anvil A - Anvil Required N - No Anvil Required O - Miniature Holder	2 - Holder Style L - External V - Miniature Square Shank VR - Miniature Round Shank	3 - Shank Square [mm] 8, 10, 12, 16, 20, 25, 32, 40, 50, 60	4 - Insert Size 2 - IC1/4" 3 - IC3/8" 4 - IC1/2" 5 - IC5/8"
5 - Insert Style U - U style V - Vertical F - F Line M - Multi+ M MF - Multi+ F Line Z - Multi+ Z T - Multi+ T 14D - Multi+ 14D MG - Mega Line	6 - Clamping C - With Clamping	7 - Insert Width (for IC5/8"V) 6, 8, 10	
8 - Tool Type CQ - Drop Head FQ - Off-Set Oil - For API Inserts	9 - RH/LH Holder None - Right Hand LH - Left Hand		

Internal Toolholders

C	A	VR	C	20	6	-	3						
1	2	3	4	5	6		7	8	9	10	11	12	

1 - Shank Type B - Anti Vibration System C - Carbide Shank S - Mini Holders	2 - Anvil A - Anvil Required N - No Anvil Required O - Miniature Holder	3 - Tool Type VR - Internal Round Shank	4 - Cooling C - With Coolant Channel	5 - Shank Front Dia. 10, 10D, 12, 13, 16 16D, 20, 25, 25D, 32, 40, 50 6.2 (Mini Adjust) 8.0 (Mini Adjust)	6 - Holder Length (Mini Holders) U - Ultra Short S - Short M - Medium L - Long T - Adjustable
7 - Insert Size 5L - IC5.0L mm 4.0K - IC4.0 mm 5.0K - IC5.0 mm 6.0 - IC6.0 mm 2 - IC1/4" 3 - IC3/8" 4 - IC1/2" 5 - IC5/8"	8 - Insert Style U - U style V - Vertical F - F Line M - Multi+ M MF - Multi+ F Line Z - Multi+ Z T - Multi+ T 14D - Multi+ 14D MG - Mega Line	9 - Clamping C - With Clamp	10 - Oil Field OIL - For API Inserts	11 - RH/LH Holder None - Right Hand LH - Left Hand	12 - Serial No. 156/... (Coarse Pitch Holder) 206/... (V6 Holder)

Micro, Microscope & Adjustable Toolholders (Sleeves)

M	H	C	20	-	4	-	4F
1	2	3	4		5		6

1 - Holder Shape S - Sleeve (Double Ended) M - Microscope (Single Ended)	2 - Holder Type V - Adjustable Holders for Mini M - Micro (Double Ended) H - Microscope Holder HS - Microscope with Square Shank HD - Microscope with Drop Head	3 - Cooling C - Coolant Channel	4 - Shank Size [mm] 10, 12, 16, 20	5 - Holder Bore Size Micro Size 3, 4, 5, 6, 7, 8, 10 Adjustable Holders (for Mini) 6.2, 8	6 - No. of Flats 4F - 4 Flats None - 2 Flats
---	---	---	--	--	---

V-CAP Toolholders

VCAP	40	-	S	E	R	27	050	-	3
1	2		4	5	6	7	8		9

1 - Holder Style	2 - D (Polygon Size)	3 - Insert Style	4 - External / Internal	5 - RH / LH
VCAP - Vargus Polygon Shank	32,40,50,63	S - Threading	E - External I - Internal	R - Right Hand L - Left Hand

6 - Cutting Radius	7 - Tool Overhang	8 - Insert Size
12-55	40-105	3 - IC3/8"

VG-Cut Toolholders for Threading

VG	E	R	2525	-	3	T12
1	2	3	4		5	6

1 - Line Name	2 - Application Approach	3 - RH / LH	4 - Shank Size
VG - Deep Grooving & Parting Off	E - External	R - Right Hand L - Left Hand	Width-Height

5 - Pocket Size	6 - Depth of Cut
3	T12 - Limit Depth of Cut 12 mm

Mini-V Holders

C	V	08	-	12	21	-
1	2	3		4	5	6

1 - Holder Type	2 - Product Line	3 - Insert Style	4 - Shank Diameter	5 - Tool Overhang	6 - RH
C - Carbide Shank None - Steel Shank	V - Mini-V	08, 11, 14, 16	6, 8, 12, 16	12, 21, 29, 30, 42, 50, 56, 64, 80	None - RH

Mini-V Sleeves

MH	C	16	-	6
1	2	3		4

1 - Holder Type	2 - Cooling	3 - Shank Dia.	4 - Sleeve Bore Dia.
MH - Microscope Holder	C - Cooling Channels	12, 16, 20	6, 8

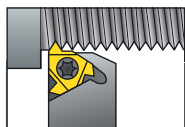

External Toolholders

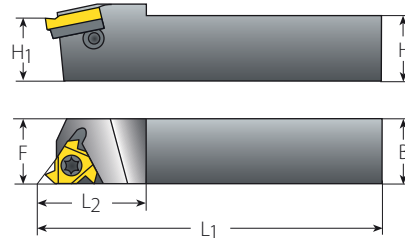

Standard

Spare Parts

Insert Size	Ordering Code	Dimensions mm										
		IC	RH/LH	H=H1=B	F	L1	L2	Insert Screw	Anvil Screw	Torx Key	Anvil RH	Anvil LH
1/4"	NL8-2			8	11	136.4	17.5	SN2T	-	K2T	-	-
	NL10-2			10	11	125.0	17.5					
	NL12-2			12	12	125.0	17.5					
3/8"	NL12-3			12	16	83.2	22	SA3T	-	K3T	-	-
	AL3/8-3			9.52	16	63.6	20.5					
	AL12-3			12	16	83.2	22					
	AL16-3			16	16	100.0	20.5					
	AL20-3			20	20	128.6	30					
	AL25-3			25	25	153.6	30					
	AL32-3			32	32	173.6	30					
1/2"	AL25-4			25	25	155.7	36	SA4T	SY4T	K4T	YE4	Y14
	AL32-4			32	32	175.7	36					
	AL40-4			40	40	205.7	36					
5/8"	AL25-5			25	32	151.6	35	SA5T	SY5T	K5T	YE5	Y15
	AL32-5			32	32	176.6	40					
	AL40-5			40	40	206.6	40					
	AL50-5			50	50	256.6	40					

The above toolholders have a 1.5° helix angle. For other helix angles, see page 201.
 The above toolholders are for RH inserts. For LH inserts, add LH to the toolholder's ordering code (Example AL20-3**LH**).

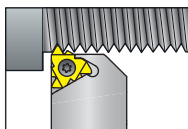

External Toolholders

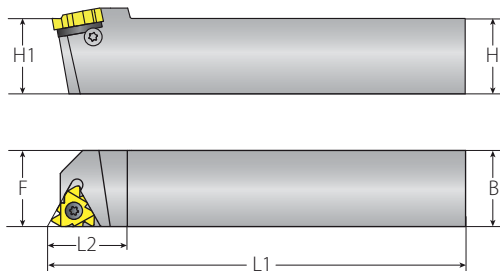

Standard F-Line

Insert Size	Ordering Code	Dimensions mm			
IC	RH	H=H1=B	F	L1	L2
1/2" F	AL25-4F	25	25	155	33
	AL32-4F	32	32	175	33
	AL40-4F	40	40	205	33

Spare Parts

Insert Screw	Anvil Screw	Torx Key	Anvil RH
SA4T	SY4T	K4T	YE4F

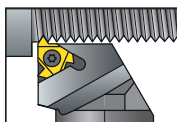

External Toolholders

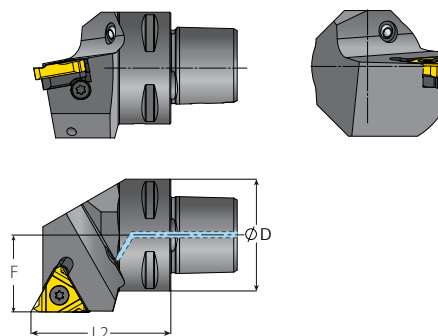

V-CAP

Insert Size	Ordering Code	Dimensions mm		
IC	RH/LH	D	F	L2
3/8"	VCAP32-SER22040-3	32	22	40
	VCAP40-SER27050-3	40	27	50
	VCAP50-SER35060-3	50	35	60
	VCAP63-SER45065-3	63	45	65

Spare Parts

Insert Screw	Anvil Screw	Torx Key	Coolant Jet	Anvil RH	Anvil LH
SA3T	SY3T	K3T	OD6	YE3	YI3
			OD8		

The above toolholders are for RH inserts. For LH inserts, add LH to the toolholder's ordering code (Example VCAP32-SER22040-3LH).

The above toolholders have a 1.5° helix angle. For other helix angles, see page 201.

External Toolholders

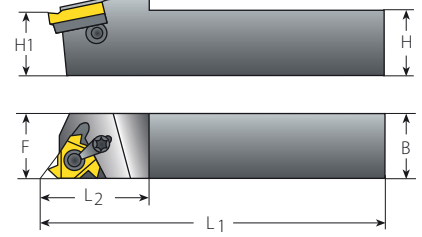
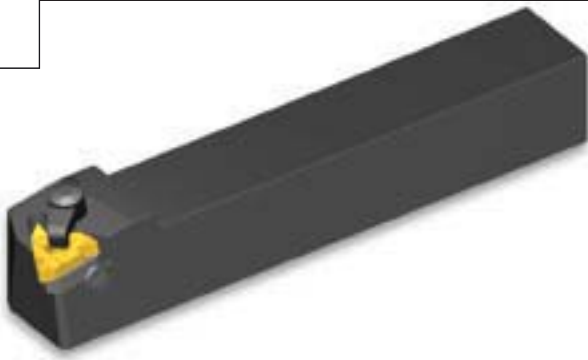
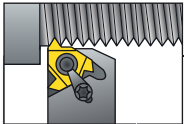

Standard with Clamp

(Dual System, Screw or Clamp)

Spare Parts

Insert Size	Ordering Code	Dimensions mm										
		RH/LH	H=H1=B	F	L1	L2	Insert Screw	Anvil Screw	Clamp	Torx Key	Anvil RH	Anvil LH
3/8"	AL16-3C		16	16	100.0	20.5	SA3T	SY3T	C3	K3CT	YE3	YI3
	AL20-3C		20	20	128.6	30						
	AL25-3C		25	25	153.6	30						
	AL32-3C		32	32	173.6	30						
1/2"	AL25-4C		25	25	155.7	36	SA4T	SY4T	C4	K4T	YE4	YI4
	AL32-4C		32	32	175.7	36						
	AL40-4C		40	40	205.7	36						
5/8"	AL25-5C		25	32	151.6	35	SA5T	SY5T	C5	K5T	YE5	YI5
	AL32-5C		32	32	176.6	40						
	AL40-5C		40	40	206.6	40						
	AL50-5C		50	50	256.6	40						

The above toolholders have a 1.5° helix angle. For other helix angles, see page 201.
 The above toolholders are for RH inserts. For LH inserts, add LH to the toolholder's ordering code (Example AL16-3CLH).

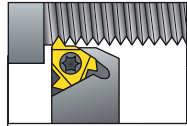

External Toolholders

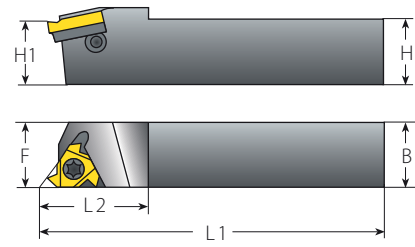

Thread Turning Toolholders

Oil & Gas

Spare Parts

Insert Size	Ordering Code	Thread Form	Connection No. or Size	Dimensions mm				Helix Angle				
				H=H1=B=F	L1	L2			Insert Screw	Anvil Screw	Torx Key	Anvil RH
3/8"	AL32-3 APIRD	APIRD 8	2.375"-20"	32	173.0	28.8	1	SA3T	SY3T	K3T	YEI3 APIRD	
	AL40-3 APIRD	APIRD 10	1.05"-3.5"	40	205.0	37.4	1					
1/2"	AL32-4 5BUT/API	5BUT, V0.038R, V0.050, V0.040, V0.055	4 1/2"-20"	32	177.0	36.6	0	SA4T	SY4T	K4T	YEI4-API-1P YEI4-5BUT	
	AL40-4 5BUT/API		NC10-NC77 all sizes	40	204.0	34.5	0					
5/8"	AL32-5OIL	V0.038R, V0.050	NC23-NC77 all sizes	32	175.9	40.0	1.5	SA5T	SY5T	K5T	YESOIL	
	AL40-5OIL	V0.038R, V0.050	NC23-NC77 all sizes	40	205.9	40.0	1.5					

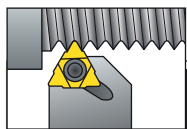

External Toolholders

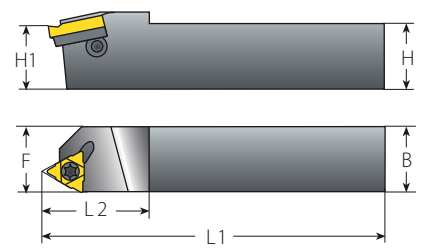

U Style

Spare Parts

Insert Size	Ordering Code	Dimensions mm								
IC	RH/LH	H=H1=B	F	L1	L2	Insert Screw	Anvil Screw	Torx Key	Anvil RH	Anvil LH
1/2"U	AL25-4U	25	25	178.4	38	SA4T	SY4T	K4T	YE4U	YI4U
	AL32-4U	32	32	178.4	38					
	AL40-4U	40	40	208.4	38					
5/8"U	AL25-5U	25	25	179.1	40	SA5T	SY5T	K5T	YE5U	YI5U
	AL32-5U	32	32	179.1	40					
	AL40-5U	40	40	209.1	40					
	AL50-5U	50	50	259.1	40					

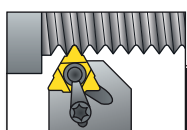

External Toolholders

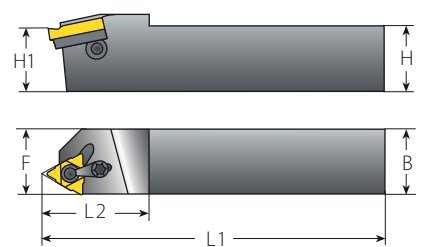

U Style with Clamp

(Dual System, Screw or Clamp)

Spare Parts

Insert Size	Ordering Code	Dimensions mm									
IC	RH/LH	H=H1=B	F	L1	L2	Insert Screw	Anvil Screw	Clamp	Torx Key	Anvil RH	Anvil LH
1/2"U	AL32-4UC	32	32	178.4	38	SA4T	SY4T	C4	K4T	YE4U	YI4U
	AL40-4UC	40	40	208.4	38						
5/8"U	AL32-5UC	32	32	179.1	40	SA5T	SY5T	C5	K5T	YE5U	YI5U
	AL40-5UC	40	40	209.1	40						
	AL50-5UC	50	50	259.1	40						

All U Style Toolholders have a 1.5° helix angle. For other helix angles see page 201.
The above toolholders are for RH inserts. For LH inserts, add LH to the toolholder's ordering code (Example AL25-4ULH).

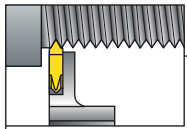

External Toolholders

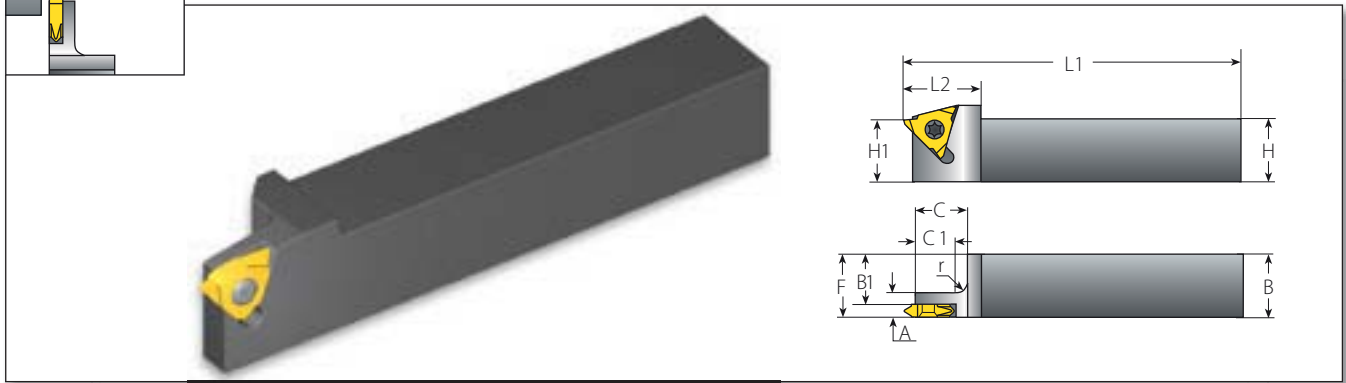

Slim Throat

Spare Parts

Insert Size		Ordering Code		Dimensions mm							Spare Parts	
IC	RH/LH	H=B=F	H1	A	B1	C	C1	L1	L2	r	Insert Screw	Torx Key
1/4"V	NL8-2V	8	10	7	4.8	12.5	11.5	60	14.0	1	SN2T	K2T
	NL10-2V	10	10	7	6.8	12.5	11.5	70	14.0	1		
	NL12-2V	12	12	7	8.8	14.5	11.5	80	14.0	3		
	NL16-2V	16	16	7	12.8	14.5	11.5	100	14.0	3		
3/8"V	NL10-3V	10	14	7	6.4	14.5	11.5	70	18.5	3	SN3TV	K3T
	NL12-3V	12	14	7	8.4	14.5	11.5	80	18.5	3		
	NL16-3V	16	16	7	12.4	14.5	11.5	100	25.0	3		
	NL20-3V	20	20	7	16.4	16.5	11.5	125	30.0	3		
	NL25-3V	25	25	7	21.4	16.5	11.5	150	30.0	5		
	NL32-3V	32	32	7	28.4	16.5	11.5	170	30.0	5		
1/2"V	NL40-3V	40	40	7	36.4	16.5	11.5	200	30.0	5	SN4T	K4T
	NL25-4V	25	25	12	20.2	16.5	11.5	150	30.0	5		
	NL32-4V	32	32	12	27.2	16.5	11.5	170	30.0	5		
	NL40-4V	40	40	12	35.2	16.5	11.5	200	30.0	5		

All Slim Throat toolholders have a 1.5° helix angle see page 201.
 The above toolholders are for RH inserts. For LH inserts, add LH to the toolholder's ordering code (Example NL8-2VLH).

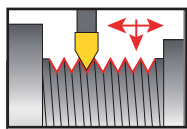

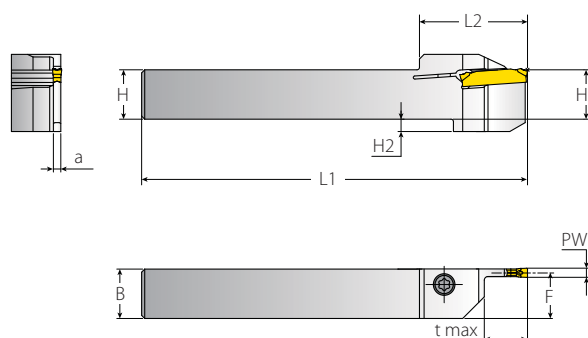

External Toolholders



VG-Cut

Spare Parts

Ordering Code		Dimensions mm								Spare Parts	
PW	RH/LH	t max	HxB	H1	F	L1	L2	a	H2		
3	VGER1212-3T12	12	12x12	12	10.8	125	35	2.4	4.0	SM3,5x14-T15	KT-15
	VGEL1212-3T12		12x12	12	10.8	125	35	2.4	4.0		
	VGER1616-3T12		16x16	16	14.8	125	35	2.4	4.0	SM4,0x18-T20	K6T
	VGEL1616-3T12		16x16	16	14.8	125	35	2.4	4.0		
	VGER2020-3T12		20x20	20	18.8	125	35	2.4	-		
	VGEL2020-3T12		20x20	20	18.8	125	35	2.4	-		
	VGER2525-3T12		25x25	25	23.8	125	35	2.4	-		
	VGEL2525-3T12		25x25	25	23.8	125	35	2.4	-		

All VG-Cut tooling have 1.5° helix angle.

External Toolholders

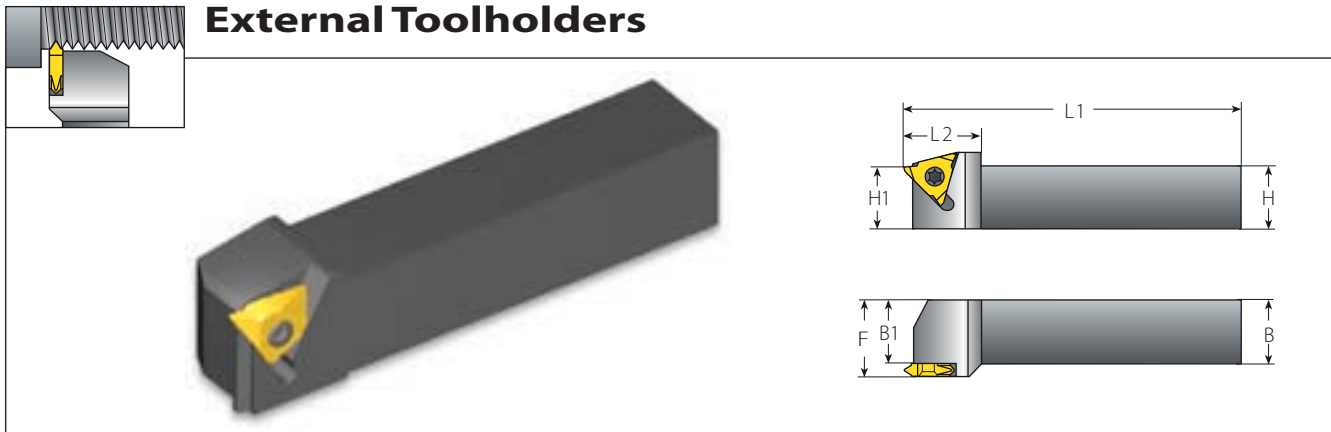

V Style

Insert Size		Ordering Code		Dimensions mm			Spare Parts	
IC	RH/LH	H=H1=B	B1	F	L1	L2	Insert Screw	Torx key
5/8"V	NL32-5V-6	32	25.5	32.0	170	40	SN6T	K6T
	NL32-5V-8	32	25.5	34.1	170	40		
	NL32-5V-10	32	25.5	35.8	170	40		
	NL32-5V-10ABUT*	32	25.5	35.8	170	40		
	NL40-5V-6	40	33.5	40.0	200	40		
	NL40-5V-8	40	33.5	42.1	200	40		
	NL40-5V-10	40	33.5	43.8	200	40		
	NL40-5V-10ABUT*	40	33.5	43.8	200	40		

All V Style toolholders have a 1° helix angle.
 The above toolholders are for RH inserts. For LH inserts, add LH to the toolholder's ordering code (Example NL32-5V-6 LH).
 * To be used only with inserts 5VER2.5ABUT...

External Toolholders



Z+ Style

Insert Size		Ordering Code		Dimensions mm			Spare Parts				
IC	RH	H=H1=B	F	L1	L2	Insert Screw	Anvil Screw	Torx Key	Anvil RH	Anvil LH	
1/2"Z	AL32-4Z	32	32	178.4	38	SA4T	SY4T	K4T	YE4Z	YI4Z	
	AL40-4Z	40	40	208.4	38						
5/8"Z	AL32-5Z	32	32	179.1	40	SA5T	SY5T	K5T	YE5Z	YI5Z	
	AL40-5Z	40	40	209.1	40						
	AL50-5Z	50	50	259.1	40						

All Z Style toolholders have a 1.5° helix angle.

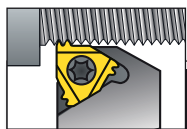

External Toolholders

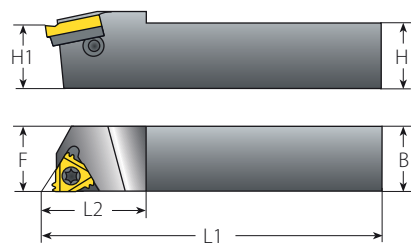

M+ Style

Insert Size	Ordering Code	Dimensions mm			
IC	RH	H=H1=B	F	L1	L2
5/8" M	AL32-5M	32	32	176.6	40
	AL40-5M	40	40	206.6	40
	AL50-5M	50	50	256.6	40

Spare Parts



Insert Screw	Anvil Screw	Torx Key	Anvil RH	Anvil LH
SA5T	SY5T	K5T	YE5M	YI5M

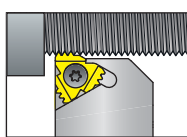

External Toolholders

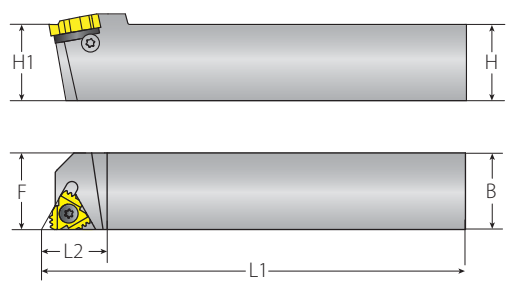

F-Line M+ Style

Insert Size	Ordering Code	Dimensions mm			
IC	RH	H=H1=B	F	L1	L2
1/2" F	AL32-4MF	32	32	175	33
	AL40-4MF	40	40	205	33

Spare Parts



Insert Screw	Anvil Screw	Torx Key	Anvil RH
SA4T	SY4T	K4T	YE4M2F

The above toolholders have a 1.5° helix angle. For other helix angles, see page 201.

External Toolholders

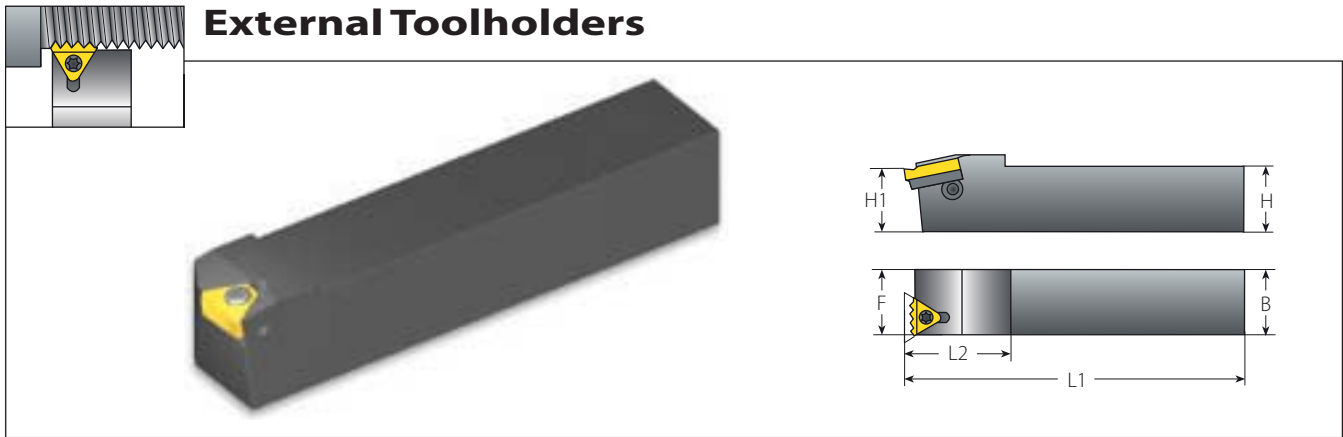

T+ Style

Insert Size	Ordering Code	Dimensions mm			
IC	RH	H=H1=B	F	L1	L2
1/2" T	AL25-4T	25	27	150	30
	AL32-4T	32	34	170	30
	AL40-4T	40	42	200	30

Multiplus

Spare Parts				
Insert Screw	Anvil Screw	Insert Torx Key	Anvil Torx Key	Anvil RH/LH
SA4T	SY4K2	K4T	K2	Y4T

All T Style toolholders have a 0° helix angle.

External Toolholders

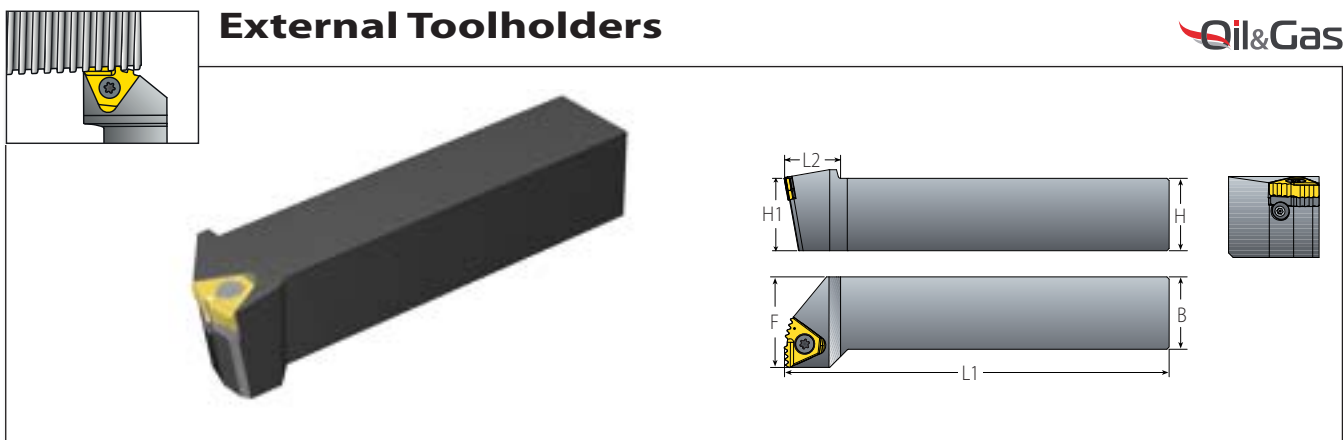

14D Standard

Insert Size	Ordering Code	Dimensions mm			
IC	RH	H=H1=B	F	L1	L2
14D	AL25-14D	25	32	150	25
	AL32-14D	32	40	170	25
	AL40-14D	40	40	200	30

Multiplus

Spare Parts			
Insert Screw	Anvil Screw & Washer	Torx Key	Anvil Key
SA5T	M4x6(14D)	KT15	K5T

14D holders are supplied without anvils. For specific applications, please use the anvils indicated in the table on page 202.

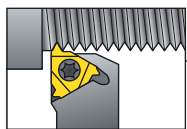

External Toolholders

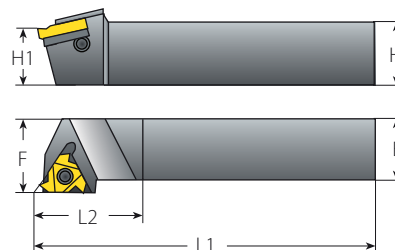
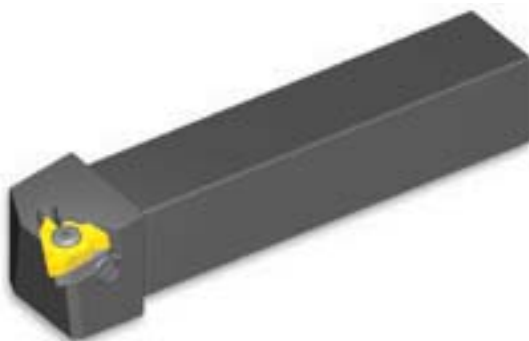

Off-Set Qualified (FQ)

Spare Parts

Insert Size		Ordering Code		Dimensions mm				Spare Parts				
IC	RH/LH	H=H1=B	F	L1	L2			Insert Screw	Anvil Screw	Torx Key	Anvil RH	Anvil LH
3/8"	AL20-3FQ	20	25	125	25			SA3T	SY3T	K3T	YE3	YI3
	AL25-3FQ	25	32	150	25							
	AL32-3FQ	32	40	170	32							
1/2"	AL25-4FQ	25	32	150	30			SA4T	SY4T	K4T	YE4	YI4
	AL32-4FQ	32	40	170	30							
5/8"	AL32-5FQ	32	40	170	35			SA5T	SY5T	K5T	YE5	YI5

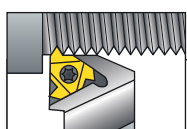

External Toolholders

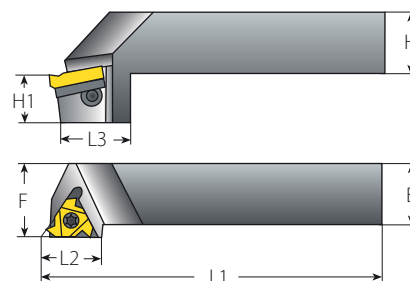

Drop Head-Qualified (CQ)

Spare Parts

Insert Size		Ordering Code		Dimensions mm				Spare Parts					
IC	RH/LH	H=B	F	L1	L2	L3	H1		Insert Screw	Anvil Screw	Torx Key	Anvil RH	Anvil LH
3/8"	AL20-3CQ	20	25	125	24	38	17.5		SA3T	SY3T	K3T	YE3	YI3
	AL25-3CQ	25	32	150	24	38	22.2						
	AL32-3CQ	32	40	170	24	38	22.2						
1/2"	AL25-4CQ	25	32	150	30	38	22.2		SA4T	SY4T	K4T	YE4	YI4
	AL32-4CQ	32	40	170	30	38	22.2						
5/8"	AL32-5CQ	32	40	170	33	43	25.4		SA5T	SY5T	K5T	YE5	YI5

The above toolholders have a 1.5° helix angle. For other helix angles see page 201.
 The above toolholders are for RH inserts. For LH inserts, add LH to the toolholder's ordering code (Example AL20-3FQLH).

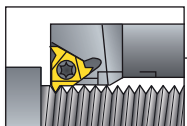



External + Internal Toolholders



Miniature Square Shank*

Spare Parts

Insert Size	Ordering Code	Dimensions mm					Min. Bore Dia. mm		
		A	L	L1 (max)	F	Insert Screw		Torx Key	
1/4"	RH/LH								
	OV8-2	8	100	25	12	29.2	SN2T	K2T	
OV10-2	10	100	25	14	36.1				

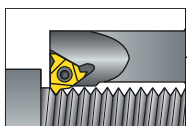



External + Internal Toolholders



Miniature Round Shank*

Spare Parts

Insert Size	Ordering Code	Dimensions mm						Min. Bore Dia. mm		
		A	L	L1 (max)	D	D1	F		Insert Screw	Torx Key
1/4"	RH/LH									
	OVR12-2	11.4	100	25	12	10	7.4	SN2T	K2T	
	OVR15-2	14.3	100	32	15	13	8.9			
OVR16D-2	15.3	100	32	16	13	8.9				

* Miniature square and round toolholders are designed for use on automatic lathes for the optical and other precision industries. They can be used for both external and internal threading, as follows:

Thread	ER	EL	IR	IL
Insert	ER	EL	IR	IL
Holder	LH	RH	RH	LH

Miniature toolholders have a 0.5° helix angle.
The above toolholders are for RH inserts. For LH inserts, add LH to the toolholder's ordering code (Example OV8-2LH).

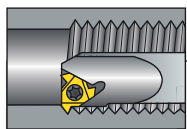

Internal Toolholders

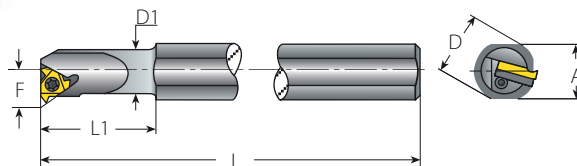

Standard

Spare Parts



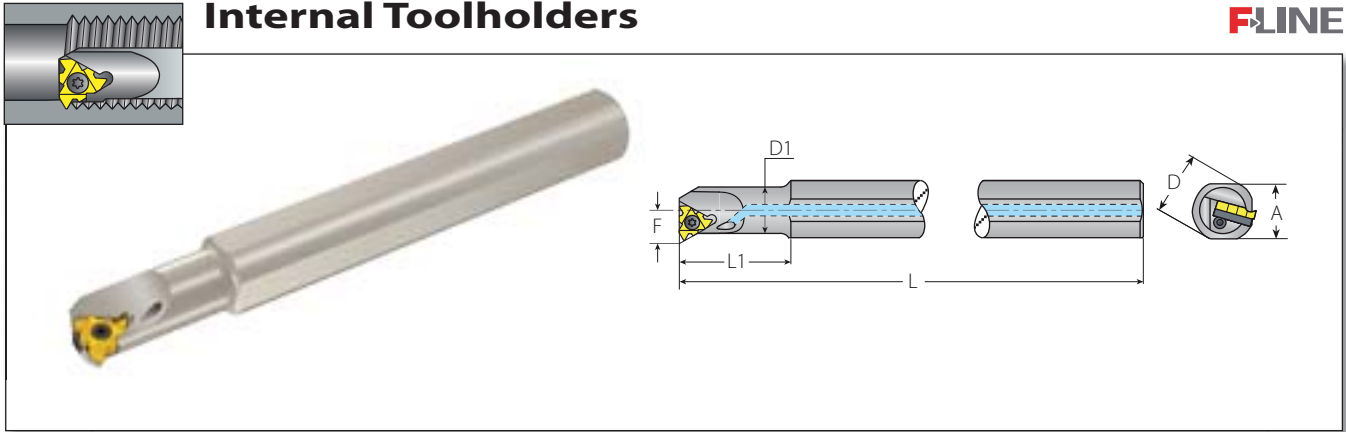

Insert Size	Ordering Code	Dimensions mm							Min. Bore Dia.	Spare Parts				
		IC	RH/LH	A	L	L1 (max)	D	D1		F	mm	Insert Screw	Anvil Screw	Torx Key
1/4"	NVR10D-2	9.5	100	40	10	10.0	7.3	13						
	NVR10-2	18.0	180	25	20	10.0	7.3	13	SN2T	-	K2T	-	-	
	NVR13-2	18.0	180	32	20	13.0	8.9	16						
3/8"	NVR13-3	18.0	180	32	20	12.7	10.3	17						
	NVR16-3	18.0	180	40	20	16.0	11.5	20	SN3T	-	K3T	-	-	
	NVR16D-3	15.2	150	64	16	16.0	11.3	20						
	AVR20-3	18.0	180	80	20	20.0	13.4	24						
	AVR25-3	29.0	250	60	32	25.0	16.3	29						
	AVR25D-3	22.6	200	100	25	24.6	16.1	29	SA3T	SY3T	K3T	Y13	YE3	
	AVR32-3	29.0	250	128	32	32.0	19.6	36						
1/2"	AVR40-3	36.0	300	160	40	40.0	23.8	44						
	NVR20-4	18.0	180	80	20	20.0	15.6	27	SN4T	-	K4T	-	-	
	AVR25-4	29.0	250	60	32	25.0	17.4	32						
	AVR25D-4	22.6	200	45	25	24.6	17.2	32						
	AVR32-4	29.0	250	128	32	32.0	21.5	39	SA4T	SY4T	K4T	Y14	YE4	
	AVR40-4	36.0	300	160	40	40.0	25.8	47						
5/8"	AVR50-4	45.0	350	200	50	50.0	30.8	57						
	AVR32-5	29.0	250	128	32	32.0	22.4	40	SN5T	SY5T	K5T	Y15	YE5	
	AVR40-5	36.0	300	160	40	40.0	26.4	48						
	AVR50-5	45.0	350	200	50	50.0	31.4	58	SA5T	SY5T	K5T	Y15	YE5	
	AVR60-5	54.0	400	240	60	60.0	36.4	69						

- The above toolholders have a 1.5° helix angle. For other helix angles, see page 201.
- Toolholders with prefix "N" cannot be used with an anvil.
- Holders with coolant channel are available as standard (Example NVRC10D-2).
- The above toolholders are for RH inserts. For LH inserts, add LH to the toolholder's ordering code (Example NVR10D-2LH).



Standard F-Line

Spare Parts

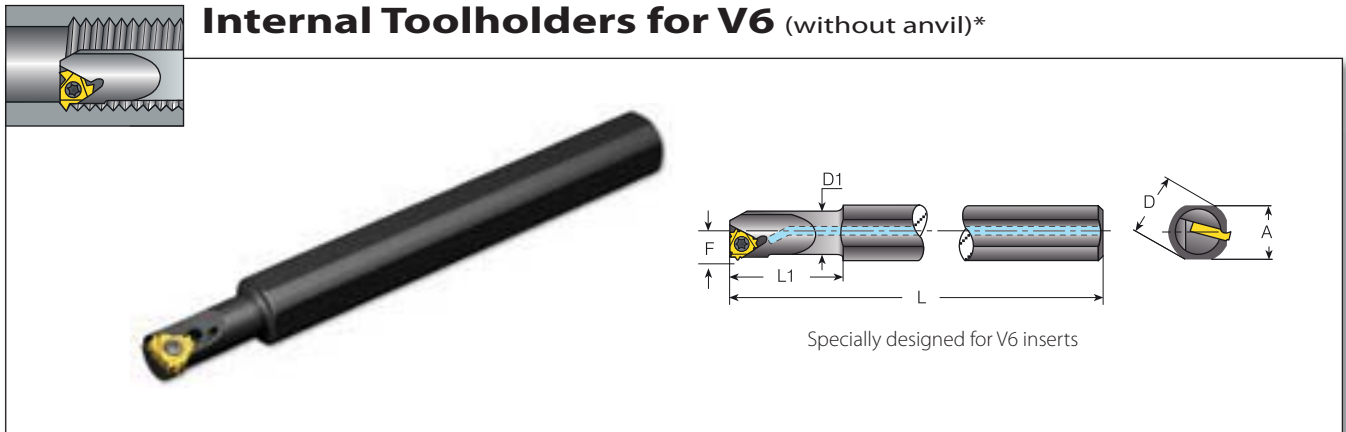

Insert Size	Ordering Code	Dimensions mm							Min. Bore Dia.				
IC	RH	A	L	L1 (max)	D	D1	F	mm	Insert Screw	Anvil Screw	Torx Key	Anvil RH	
1/2" F	AVRC25-4F	29.0	250	60	32	25.0	17.9	32	SA4T	SY4T	K4T	Y14F	
	AVRC25D-4F	22.6	200	100	25	24.6	17.9	32					
	AVRC32-4F	29.0	250	128	32	32.0	21.6	39					
	AVRC40-4F	36.0	300	160	40	40.0	25.4	47					
	AVRC50-4F	45.0	350	200	50	50.0	30.6	57					

The above toolholders have a 1.5° helix angle. For other helix angles, see page 201.



V6 Style

Spare Parts

Insert Size	Ordering Code	Dimensions mm							Min. Bore Dia.		
IC	RH	A	L	L1 (max)	D	D1	F	mm	Insert Screw	Torx Key	
3/8" V6	NVRC13-3-206/001	18	180	32	20	12.7	10.3	17	SN3TM	K3T	
	NVRC16-3-206/002	18	180	40	20	16	11.5	20			
	NVRC16D-3-206/003	15.2	150	64	16	16	11.3	20	SN3T		

* V6 inserts cannot be used on standard internal toolholders without anvil. For this purpose you must use one of these special V6 toolholders. The above toolholders have a 1.5° helix angle.

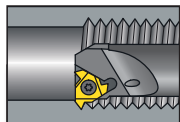

Internal Toolholders

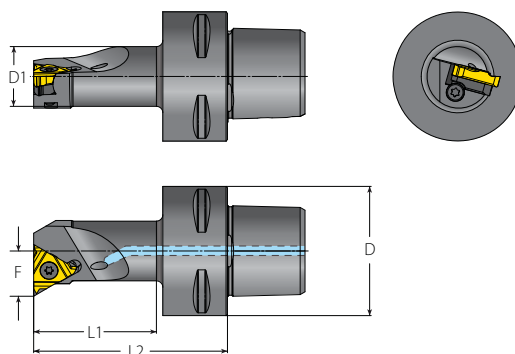

V-CAP

Spare Parts

Insert Size		Ordering Code						Min. Bore Dia.						
IC	RH/LH	D1	D	F	L2	L1 (max)	mm	Insert Screw	Anvil Screw	Torx Key	Coolant Jet	Anvil RH	Anvil LH	
3/8"	VCAP40-SIR12060-3	15.5	40	12	60	37	20	SN3T	-	K3T	OD6	-	-	
	VCAP40-SIR14060-3	18.5		14	60	38	25	SA3T	SY3T	K3T	OD6	YI3	YE3	
	VCAP40-SIR17070-3	24.5		17	70	48	32							
	VCAP40-SIR22090-3	32.0	22	90	69	40								
	VCAP40-SIR27080-3	39.5	27	80	60	50	SN3T	-	K3T	OD6	-	-		
	VCAP50-SIR12060-3	15.5	50	12	60	35	20	SA3T	SY3T	K3T	OD6	YI3	YE3	
	VCAP50-SIR14060-3	18.5		14	60	36	25							
	VCAP50-SIR17070-3	24.5		17	70	47	32							
	VCAP50-SIR22090-3	32.0	22	90	68	40	SA3T	SY3T	K3T	OD6	YI3	YE3		
	VCAP50-SIR27105-3	40.0	27	105	84	50								
	VCAP63-SIR14070-3	18.5	14	70	42	25							SA3T	SY3T
	VCAP63-SIR17075-3	24.5	17	75	48	32								
VCAP63-SIR22090-3	32.0	22	90	64	40									
VCAP63-SIR27105-3	40.0	27	105	80	50									

The above toolholders have a 1.5° helix angle. For other helix angles, see page 201.
 The above toolholders are for RH inserts. For LH inserts, add LH to the toolholder's ordering code (Example VCAP40-SIL12060-3**LH**).

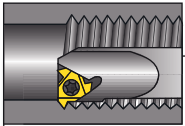

Internal Toolholders

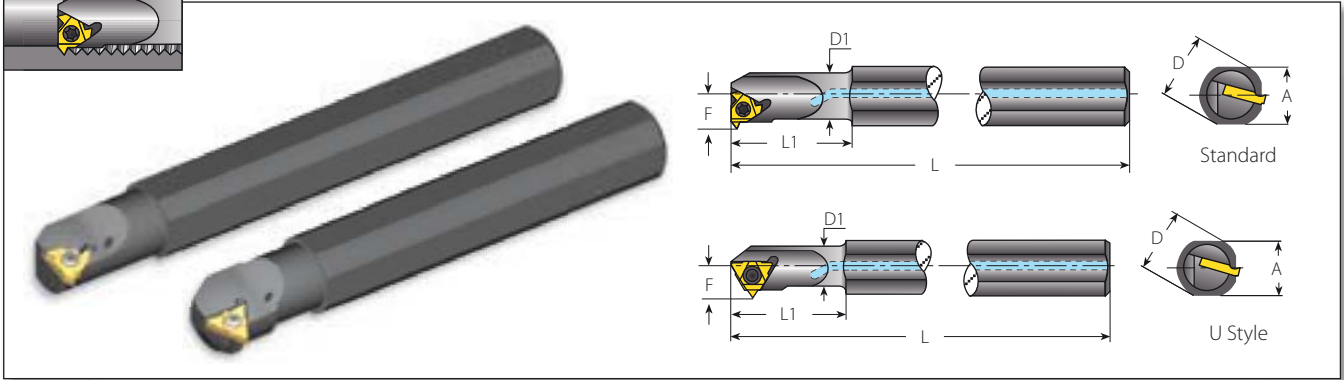

Standard for Coarse Pitch

Standard for Coarse Pitch										Spare Parts	
Insert Size	Ordering Code		Dimensions mm				F to Insert	Holder Helix			
IC	RH	LH	A	L	L1 (max)	D	D1	mm	Deg.	Insert Screw	Torx Key
1/4"	NVRC10-2-156/001	NVRC10-2LH-156/036	18.0	180	25.0	20	10.1	6.53	3.0	SN2T	K2T
	NVRC11-3-156/005	NVRC11-3LH-156/025	18.0	180	25.4	20	11.2	8.30	4.5	SN3TM	K3T
3/8"	NVRC13-3-156/006	NVRC13-3LH-156/028	18.0	180	32.0	20	13.0	9.05	4.0	SN3T	K3T
	NVRC13-3-156/016	NVRC13-3LH-156/026	18.0	180	34.0	20	13.8	8.90	2.5		
1/2"	NVRC17-4-156/007	NVRC17-4LH-156/023	18.0	180	40.0	20	16.7	11.45	4.0	SN4TM	K4T
	NVRC20-4-156/008	NVRC20-4LH-156/024	18.0	180	50.0	20	19.6	12.55	3.5	SN4T	K4T
	NVRC20-4-156/009	NVRC20-4LH-156/033	18.0	180	50.0	20	19.6	12.55	3.0		
5/8"	NVRC25-5-156/012	NVRC25-5LH-156/017	29.0	250	60.0	32	25.0	16.78	3.3	SN5TM	K5T
	NVRC28-5-156/010	NVRC28-5LH-156/034	29.0	250	50.0	32	28.0	17.80	3.5		

U Style for Coarse Pitch

U Style for Coarse Pitch										Spare Parts	
Insert Size	Ordering Code		Dimensions mm				F to Insert	Holder Helix			
IC	RH	LH	A	L	L1 (max)	D	D1	mm	Deg.	Insert Screw	Torx Key
6.0U	NVRC8-6.0U-156/003	NVRC8-6.0ULH-156/037	18.0	180	24.0	20	8.0	5.86	4.0	SN6MT	K6MT
1/4"U	NVRC10-2U-156/004	NVRC10-2ULH-156/038	18.0	180	32.0	20	10.0	7.40	4.0	SM2T8	K2T
	NVRC11-2U-156/002	NVRC11-2ULH-156/035	18.0	180	32.0	20	11.2	7.30	3.0		
3/8"U	NVRC11-3U-156/020	NVRC11-3ULH-156/029	18.0	180	32.0	20	11.0	8.23	4.5	SN3TM	K3T
	NVRC14-3U-156/018	NVRC14-3ULH-156/030	18.0	180	38.0	20	13.4	9.99	4.5		
	NVRC15-3U-156/019	NVRC15-3ULH-156/031	18.0	180	38.0	20	15.4	10.99	4.0		
1/2"U	NVRC20-4U-156/011	NVRC20-4ULH-156/021	18.0	180	40.0	20	19.2	13.68	4.0	SN4T	K4T
	NVRC25-4U-156/013	NVRC25-4ULH-156/032	29.0	250	60.0	32	25.0	17.63	3.5		
	NVRC32-4U-156/014	NVRC32-4ULH-156/022	29.0	250	60.0	32	29.7	18.76	3.3	SA4T	K4T
5/8"U	NVRC32-5U-156/015	NVRC32-5ULH-156/027	29.0	250	60.0	32	31.6	20.96	3.2	SN5T	K5T

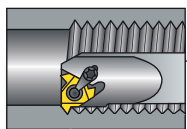

Internal Toolholders

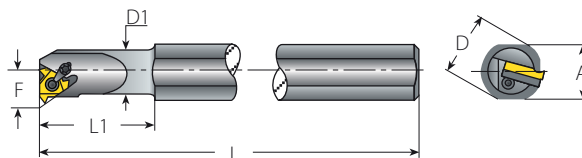

Standard with Clamp

(Dual System, Screw or Clamp)

Spare Parts

Insert Size	Ordering Code	Dimensions mm							Min. Bore Dia. mm	Spare Parts					
		IC	RH/LH	A	L	L1 (max)	D	D1		F	Insert Screw	Anvil Screw	Clamp	Torx Key	Anvil RH
3/8"	AVR20-3C	18.0	180	80	20	20.0	13.4	24	SA3T	SY3T	C3	K3CT	YI3	YE3	
	AVR25-3C	28.0	250	60	32	25.0	16.3	29							
	AVR25D-3C	22.6	200	100	25	24.6	16.1	29							
	AVR32-3C	29.0	250	128	32	32.0	19.6	36							
	AVR40-3C	36.0	300	160	40	40.0	23.8	44							
1/2"	AVR25-4C	29.0	250	128	32	25.0	17.4	32	SA4T	SY4T	C4	K4T	YI4	YE4	
	AVR25D-4C	22.6	200	100	25	24.6	17.2	32							
	AVR32-4C	29.0	250	128	32	32.0	21.5	39							
	AVR40-4C	36.0	300	160	40	40.0	25.8	47							
5/8"	AVR32-5C	29.0	250	128	32	32.0	22.4	40	SA5T	SY5T	C5	K5T	YI5	YE5	
	AVR40-5C	36.0	300	160	40	40.0	26.4	48							
	AVR50-5C	45.0	350	200	50	50.0	31.4	58							
	AVR60-5C	54.0	400	240	60	60.0	36.4	69							

- The above toolholders have a 1.5° helix angle. For other helix angles, see page 201.
- Holders with coolant channel available as standard (Example AVR**C**20-3C).
- The above toolholders are for RH inserts. For LH inserts, add LH to the toolholder's ordering code (Example AVR20-3**CLH**).

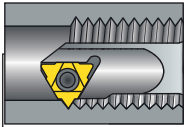

Internal Toolholders

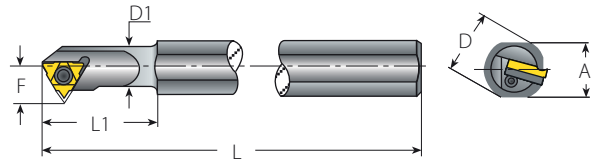

U Style

Spare Parts

Insert Size		Ordering Code		Dimensions mm					Min. Bore Dia.	Spare Parts				
IC	RH/LH	A	L	L1 (max)	D	D1	F	mm	Insert Screw	Anvil Screw	Torx Key	Anvil RH	Anvil LH	
1/2"U	AVR32-4U	29	250	128	32	32	25.5	42	SA4T	SY4T	K4T	YI4U	YE4U	
	AVR40-4U	36	300	160	40	40	29.5	51						
5/8"U	NVR32-5U	29	250	128	32	32	24.7	42	SN5T	-	K5T	-	-	
	AVR40-5U	36	300	160	40	40	29.4	51						
	AVR50-5U	45	350	200	50	50	34.3	63	SA5T	SY5T	K5T	YI5U	YE5U	
	AVR60-5U	54	400	240	60	60	39.3	74						

- The above toolholders have a 1.5° helix angle. For other helix angles, see page 201.
- Holders with coolant channel available as standard (Example AVRC32-4U).
- The above toolholders are for RH inserts. For LH inserts, add LH to the toolholder's ordering code (Example AVR32-4ULH).

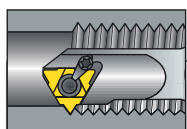

Internal Toolholders

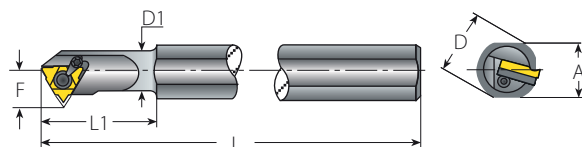

U style with Clamp

(Dual System, Screw or Clamp)

Spare Parts

Insert Size		Ordering Code		Dimensions mm					Min. Bore Dia.	Spare Parts					
IC	RH/LH	A	L	L1 (max)	D	D1	F	mm	Insert Screw	Anvil Screw	Clamp	Torx Key	Anvil RH	Anvil LH	
1/2"U	AVR32-4UC	29.0	250	128	32	32.0	25.5	42	SA4T	SY4T	C4	K4T	Y14U	YE4U	
	AVR40-4UC	36.0	300	160	40	40.0	29.5	51							
5/8"U	AVR40-5UC	36.0	300	160	40	40.0	29.4	53	SA5T	SY5T	C5	K5T	Y15U	YE5U	
	AVR50-5UC	45.0	350	200	50	50.0	34.4	63							
	AVR60-5UC	54.0	400	240	60	60.0	39.3	74							

The above toolholders have a 1.5° helix angle. For other helix angles, see page 201.

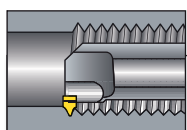

Internal Toolholders

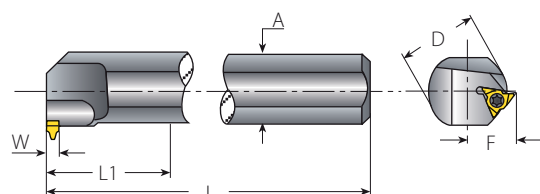

V Style

Spare Parts

Insert Size		Ordering Code		Dimensions mm					Spare Parts	
IC	RH/LH	A	L	L1 (max)	D	F	W	Insert Screw	Torx Key	
5/8"V	NVR40-5V	36	300	160	40	28.4	6.5	SN6T	K6T	
	NVR50-5V	45	350	200	50	33.4	6.5			
	NVR60-5V	54	400	240	60	38.0	6.5			

The above toolholders have a 1.0° helix angle.

Minimum Bore Diameter

Holder	Pitch mm	6.0 ISO	8.0 ISO	10.0 ISO
	Pitch tpi	4 UN	3 UN	2.5 W
NVR40-5V		48	54	62
NVR50-5V		58	58	62
NVR60-5V		68	68	68

The above toolholders are for RH inserts. For LH inserts, add LH to the toolholder's ordering code (Example AVR32-4UCLH). Holders with coolant channel available as standard (Example AVR32-4UC).

Internal Toolholders

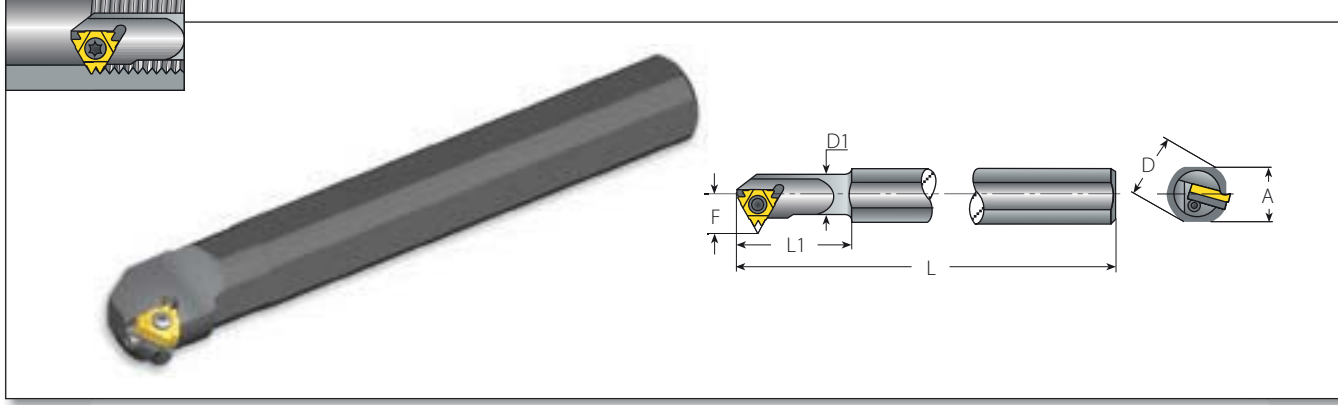

Z+ Style

Insert Size	Ordering Code	Dimensions mm							Min. Bore Dia.
IC	RH	A	L	L1 (max)	D	D1	F	mm	
1/2"Z	AVR32-4Z	29	250	128	32	32	25.5	42	
	AVR40-4Z	36	300	160	40	40	29.5	51	
5/8"Z	NVR32-5Z	29	250	128	32	32	24.7	42	
	AVR40-5Z	36	300	160	40	40	29.4	53	
	AVR50-5Z	45	350	200	50	50	34.3	63	
	AVR60-5Z	54	400	240	60	60	39.3	74	

Spare Parts



Insert Screw	Anvil Screw	Torx Key	Anvil RH	Anvil LH
SA4T	SY4T	K4T	YI4Z	YE4Z
SN5T	-	K5T	-	-
SA5T	SY5T	K5T	YI5Z	YE5Z

Internal Toolholders

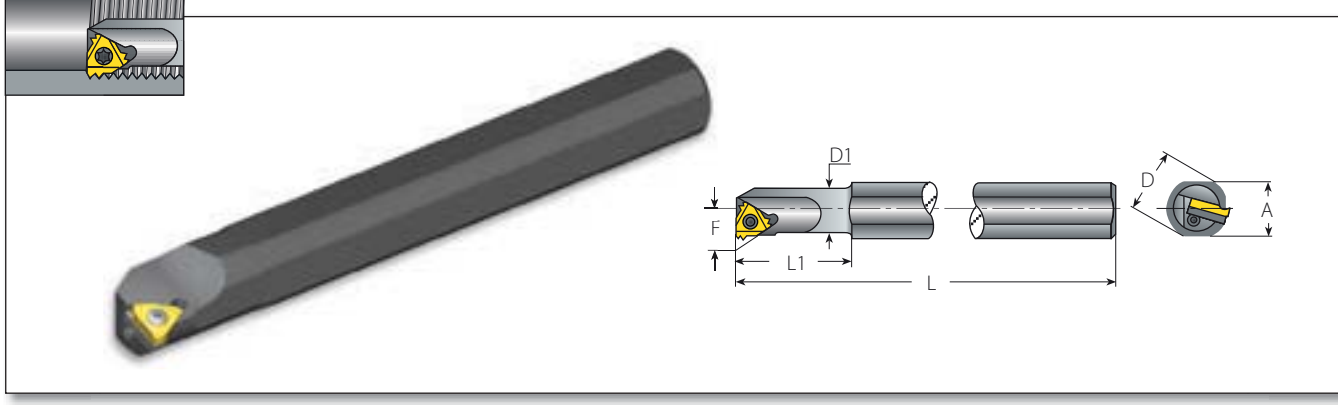

M+ Style

Insert Size	Ordering Code	Dimensions mm							Min. Bore Dia.
IC	RH	A	L	L1 (max)	D	D1	F	mm	
5/8"M	AVR32-5M	29	250	128	32	32	22.4	40	
	AVR40-5M	36	300	160	40	40	26.4	48	
	AVR50-5M	45	350	200	50	50	31.4	58	
	AVR60-5M	54	400	240	60	60	36.4	69	

Spare Parts



Insert Screw	Anvil Screw	Torx Key	Anvil RH	Anvil LH
SN5T	SY5T	K5T	YI5M	YE5M
SA5T	SY5T	K5T	YI5M	YE5M

The above toolholders have a 1.5° helix angle. For other helix angles, see page 201. Holders with coolant channel available as standard (Example AVRC32-4Z).

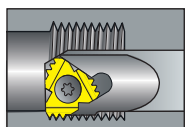

Internal Toolholders

FLINE

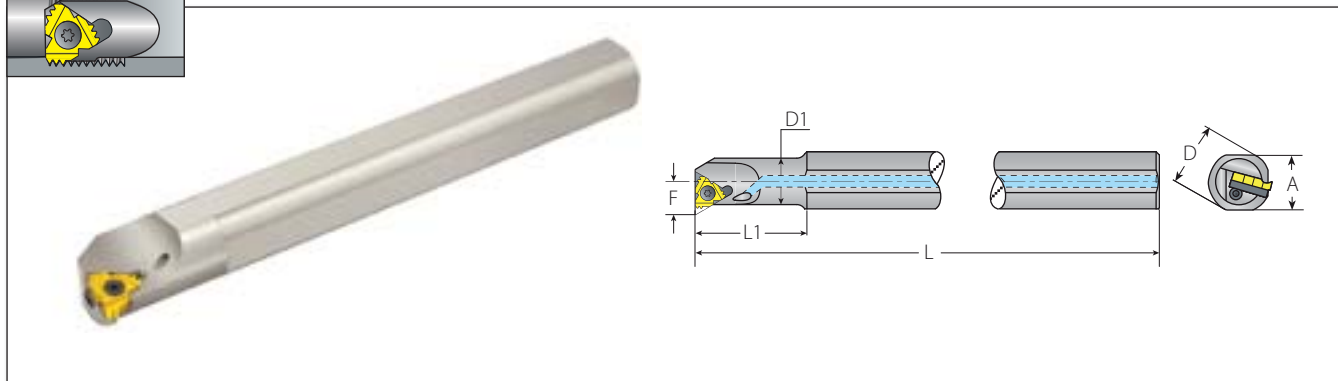

F-Line M+ Style

Spare Parts

Multiplus

Insert Size	Ordering Code	Dimensions mm							Min. Bore Dia.				
IC	RH	A	L	L1 (max)	D	D1	F	mm	Insert Screw	Anvil Screw	Torx Key	Anvil RH	
1/2" F	AVRC25-4MF	29	250	60	32	25.0	17.9	32	SA4T	SY4T	K4T	Y14M2F	
	AVRC25D-4MF	22.6	200	100	25	24.6	17.9	32					
	AVRC32-4MF	29	250	128	32	32.0	21.4	39					
	AVRC40-4MF	36	300	160	40	40.0	25.6	47					
	AVRC50-4MF	45	350	200	50	50.0	30.6	57					

The above toolholders have a 1.5° helix angle. For other helix angles, see page 201.

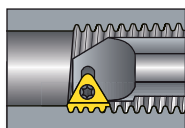

Internal Toolholders

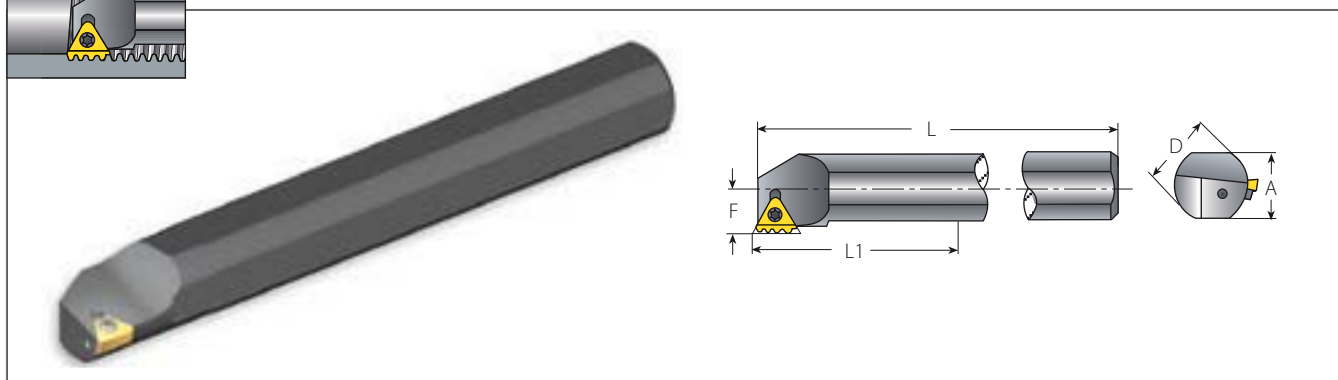

T+ Style

Spare Parts

Multiplus

Insert Size	Ordering Code	Dimensions mm							Min. Bore Dia.					
IC	RH	A	L	L1 (max)	D	F	mm	mm	Insert Screw	Anvil Screw	Torx Key	Anvil Torx Key	Anvil RH/LH	
1/2" T	AVR40-4T	36	300	160	40	23.3	60	SA4T	SY4K2	K4T	K2	Y4T		
	AVR50-4T	45	350	200	50	28.3	70							
	AVR60-4T	54	400	240	60	33.3	80							

All toolholders have a 0° helix angle.
 Holders with coolant channel available as standard (Example: AVRC-4T).

Internal Toolholders

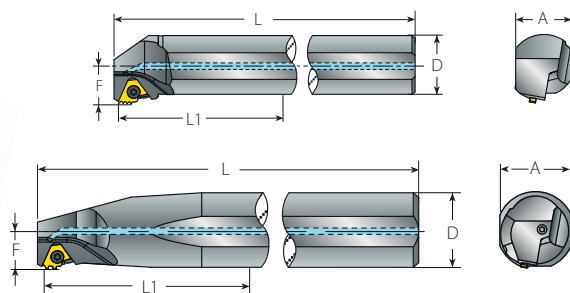
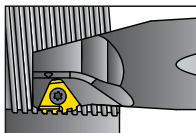

14D Standard

Insert Size	Ordering Code	Dimensions mm						Min. Bore Dia.
IC	RH	A	L	L1 (max)	D	F	mm	
14D	AVRC40-14D	37	300	160	40	26	54.5	
	AVRC50-14D	46	300	160	50	25	54.5	

Spare Parts



Insert Screw	Anvil Screw & Washer	Torx Key	Anvil Key
SA5T	M4x6(14D)	K5T	KT15

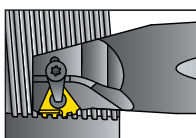

Internal Toolholders

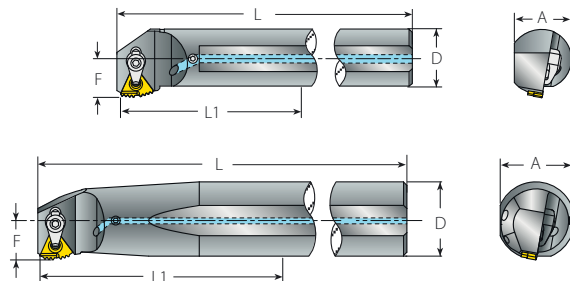

14D Standard with Clamp

Insert Size	Ordering Code	Dimensions mm						Min. Bore Dia.
IC	RH	A	L	L1 (max)	D	F	mm	
14D	AVRC40-14DC	37	300	160	40	26	54.5	
	AVRC50-14DC	46	300	160	50	25	54.5	

Spare Parts



Insert Screw	Anvil Screw & Washer	Clamp	Torx Key	Anvil Key
SA5T	M4x6(14D)	C5	K5T	KT15

14D holders are supplied without anvils. For specific applications, please use the anvils indicated in the table on page 202.

Internal Toolholders

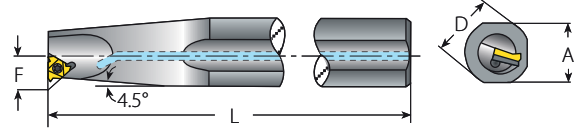
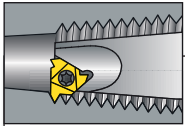

Thread Turning Toolholders

Oil & Gas

Spare Parts

Insert Size	Ordering Code	Thread Form	Connection No. or Size	Dimensions mm				Helix Angle	Spare Parts					
				A	L	D	F		Insert Screw	Anvil Screw	Torx Key	Anvil RH		
3/8"	AVRC25-3 APIRD	APIRD 8 APIRD 10	2.375"-20" 1.315"-3.5"	29	250	25	14.5	1						
	AVRC32-3 APIRD	APIRD 8 APIRD 10	2.375"-20" 1.66"-3.5"	29	250	32	19.6	1	SA3T	SY3T	K3T	YEI3-APIRD		
	AVRC40-3 APIRD	APIRD 8 APIRD 10	2.375"-20" 1.9"-3.5"	36	300	40	22.0	1						
1/2"	AVRC40-4BUT/API	5BUT, V.038R, V.050, V.040, V.055	4 1/2"-20" NC10-NC77 all sizes	36	300	40	24.2	0	SA4T	SY4T	K4T	YEI4-API-1P YEI4-5BUT		
	AVR50-5OIL	V0.038R	NC23-NC38	45	300	50	22.6	1.5						
5/8"	AVRC50-5OIL	V0.038R	NC23-NC38						SA5T	SY5T	K5T	YI5OIL		
	AVR80-5OIL	V0.050R	NC40-NC77											
	AVRC80-5OIL	V0.050R	NC40-NC77	72	400	80	39.7	1.5						

Toolholders ordered with an internal coolant channel have an internal BSP 1/2" thread for connection to the flexible coolant pipe.

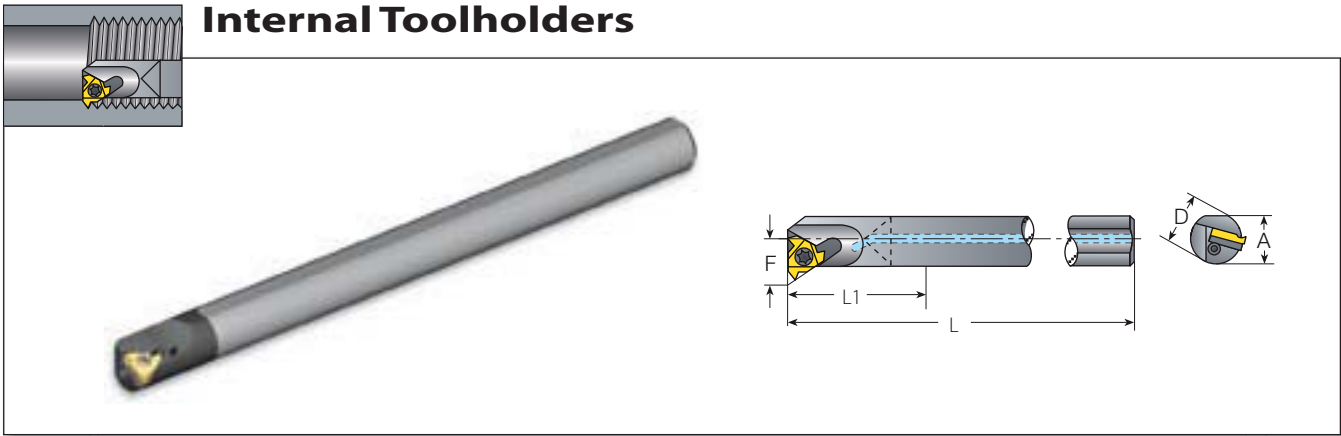

Standard with Carbide Shank

Insert Size	Ordering Code	Dimensions mm						Min. Bore Dia.	Spare Parts				
		IC	RH/LH	D	A	F	L		L1 (max)	mm	Insert Screw	Anvil Screw	Torx Key
1/4"	CNVRC10-2	10	9.5	7.3	150	60	13	SN2T	-	K2T	-	-	
	CNVRC12-2	12	11.7	8.3	180	72	15	-	-	-	-		
3/8"	CNVRC16-3	16	15.6	11.5	200	96	20	SN3T	-	K3T	-	-	
	CAVRC20-3	20	19.5	13.4	250	120	24	SA3T	SY3T	K3T	YI3	YE3	
1/2"	CNVRC20-4	20	19.5	13.8	250	120	25	SN4T	-	K4T	-	-	

Toolholders with prefix "CN" cannot be used with an anvil. The above toolholders have coolant channel as standard.

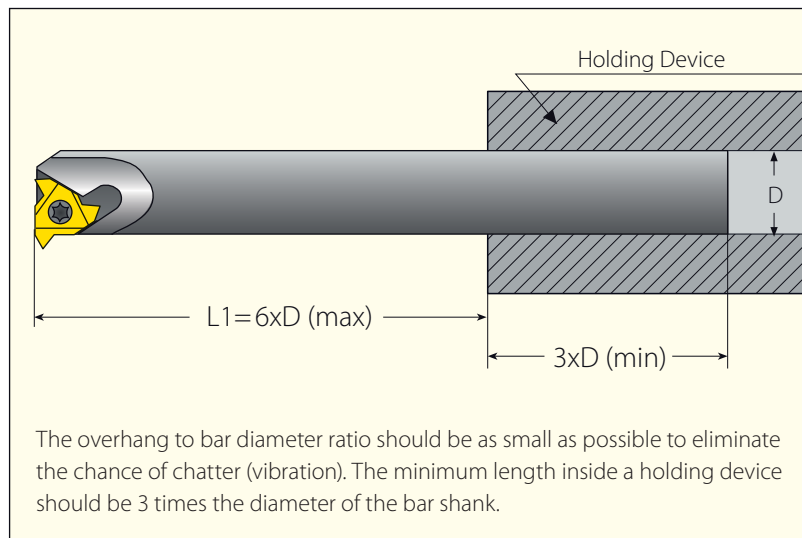

The above toolholders have 1.5° helix angle. For other helix angles see page 201.
 The above toolholders are for RH inserts. For LH inserts, add LH to the toolholder's ordering code (Example CNVRC10-2LH).

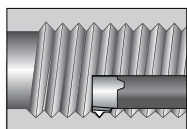

Internal Toolholders

Mini-V

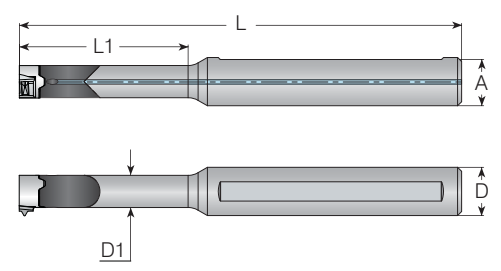

Carbide Shank with Alloy Steel Head

Spare Parts

Insert Style	Ordering Code		Dimensions mm					Spare Parts		
	Sleeve	RH	A	L	L1	D	D1	Screw	Size	Torx Key
V08	-	CV08-1221	11.5	80.5	21	12	6	SNV08	M2.6x0.45x8	K2T
	-	CV08-1230		90.5	30					
V11	-	CV11-1229	11.5	95.0	29	12	8	SNV11	M3.5x0.6x10	K3T
	-	CV11-1242		110.0	42					
V16	-	CV16-1240	11.0	130.0	40	12	11	SNV16	M5x0.8x12	K4T
	-	CV16-1256		130.0	56					
	-	CV16-1280		150.0	80					

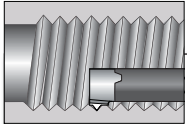

Internal Toolholders

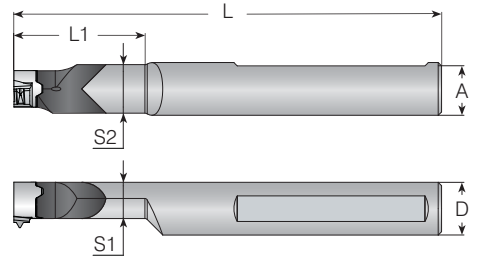

Mini-V



Thread Turning Toolholders

Reinforced Carbide Shank

Spare Parts

Insert Style	Ordering Code		Dimensions mm						Spare Parts		
	Sleeve	RH	A	L	L1	D	S1	S2		Size	
V14	-	CV14-1234	11	100.0	34.0	12	9.3	11.9	SNV14	M4x0.7x12	KT15
	-	CV14-1634	15	100.0	34.0	16	9.3	12.45			
V16	-	CV16-1640	15	129.7	39.7	16	11	14.75	SNV16	M5x0.8x12	K4T

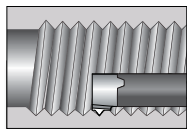

Internal Toolholders

Mini-V

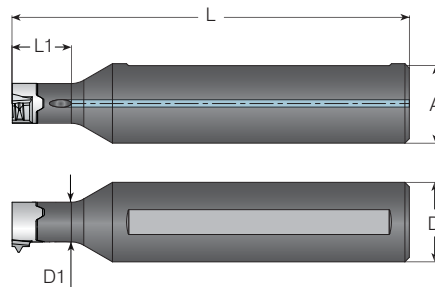

Alloy Steel Shank

Spare Parts

Insert Style		Ordering Code	Dimensions mm					Screw		Torx Key
Sleeve	RH		A	L	L1	D	D1	Size		
V08	-	V08-1612	15.6	80	12	16	6	SNV08	M2.6x0.45x8	K2T
V11	-	V11-1612	15.6	80	12	16	8	SNV11	M3.5x0.6x10	K3T
V16	-	V16-1622	15.0	100	22	16	11	SNV16	M5.0x0.8x12	K4T

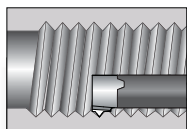

Internal Toolholders

Mini-V

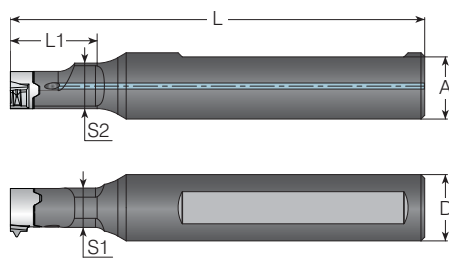

Alloy Steel Shank

Spare Parts

Insert Style		Ordering Code	Dimensions mm						Screw		Torx Key
Sleeve	RH		A	L	L1	D	S1	S2	Size		
V14	-	V14-1620	15.0	100	20	16	9.5	11	SNV14	M4x0.7x12	KT15

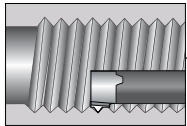

Internal Toolholders

Mini-V

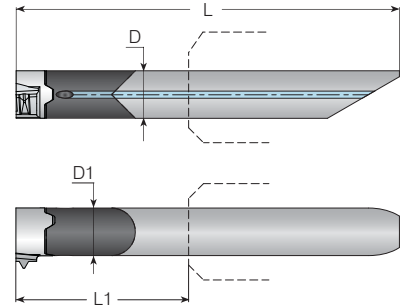

Holder for Sleeve Clamping

Spare Parts

Insert Style	Ordering Code	Dimensions mm					Ordering Code	Spare Parts		
	RH	A	L	L1 (max)	D	D1	Sleeve	Screw	Size	Torx Key
V08	CV08-0621	-	45	21	6	6	MHC...-6	SNV08	M2.6x0.45x8	K2T
V11	CV11-0829	-	64.5	29	8	8	MHC...-8	SNV11	M3.5x0.6x10	K3T

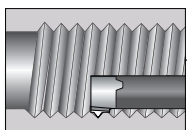

Internal Toolholders

Mini-V

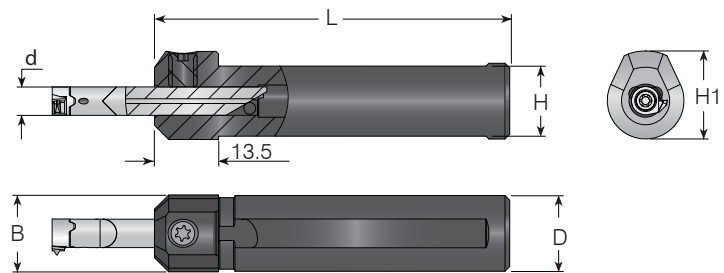

Sleeves

Spare Parts

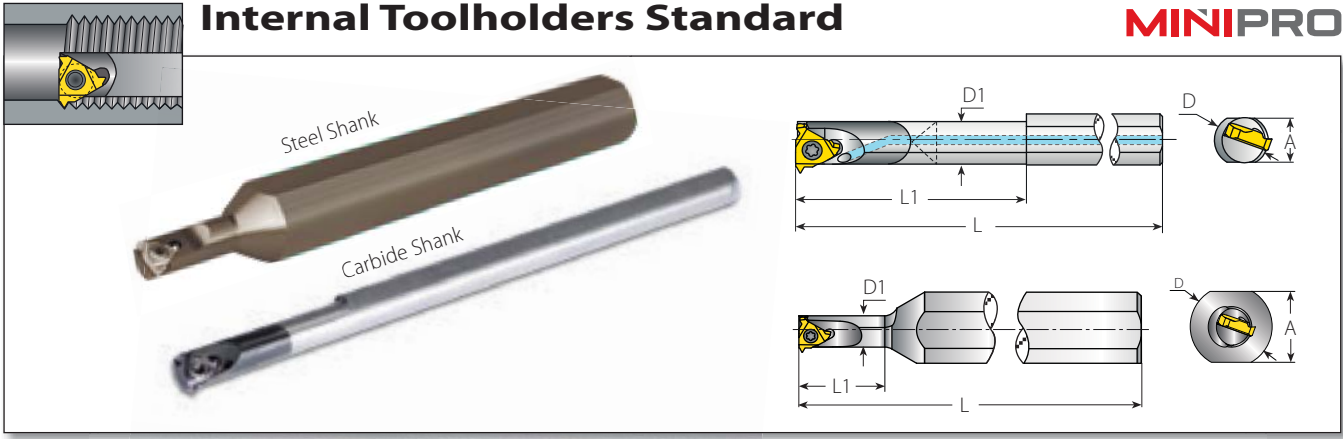

Ordering Code		Dimensions mm				Spare Parts	
d	Sleeve	D=B	H1	H	L	Screw	Torx Key
6	MHC12-6	12	16.0	10.8	70.0	SL7DT15	KT15
	MHC16-6	16	18.6	14.8	75.0		
	MHC20-6	20	22.0	18.8	84.0		
8	MHC16-8	16	18.6	14.8	100.0		
	MHC20-8	20	22.0	18.8	103.5		

Internal Toolholders Standard



Mini-3 Standard

Spare Parts

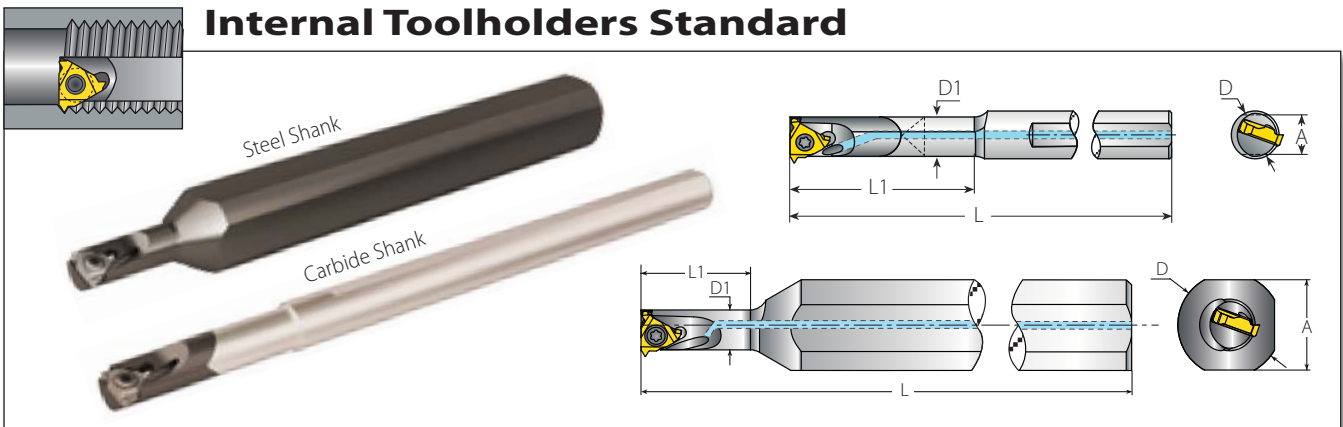

Insert Size	Ordering Code	Dimensions mm					Anti-Vibration System		
IC	RH/LH	A	L	L1	D	D1		Insert Screw	Torx Key
4.0	SNVR5-4.0K	11.0	100	12	12	5.1	No	SN4MT	K6MT
	CNVR5-4.0K	5.2	100	26	6	5.1	Carbide Shank		

Internal Toolholders Standard



Mini-3 Standard

Spare Parts

Insert Size	Ordering Code	Dimensions mm					Anti-Vibration System		
IC	RH/LH	A	L	L1	D	D1		Insert Screw	Torx Key
5.0	NVRC7-5.0K	15	125	18	16	6.6	No	SN5MT	K6MT
	CNRC7-5.0K	7	125	31	8	6.6	Carbide Shank		

The above toolholders have 2.5° helix angle.
 The above toolholders are for RH inserts. For LH inserts, add LH to the toolholder's ordering code (Example: CNVRC5-4.0**LH**).

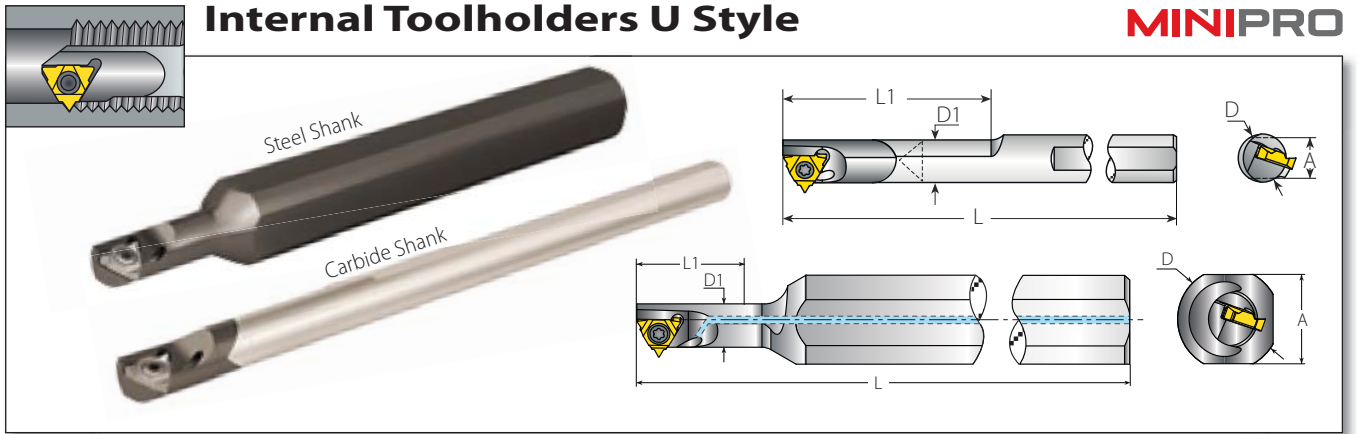

MINIPRO

Mini-3 U Style

Insert Size		Ordering Code	Dimensions mm				Anti-Vibration System	Spare Parts	
IC mm	RH/LH	A	L	L1	D	D1		Insert Screw	Torx Key
5.0U	NVRC8-5.0KU	15	125	21	16	7.3	No	SN5MT	K6MT
	CNVRC8-5.0KU	7	125	35	8	7.3	Carbide Shank		

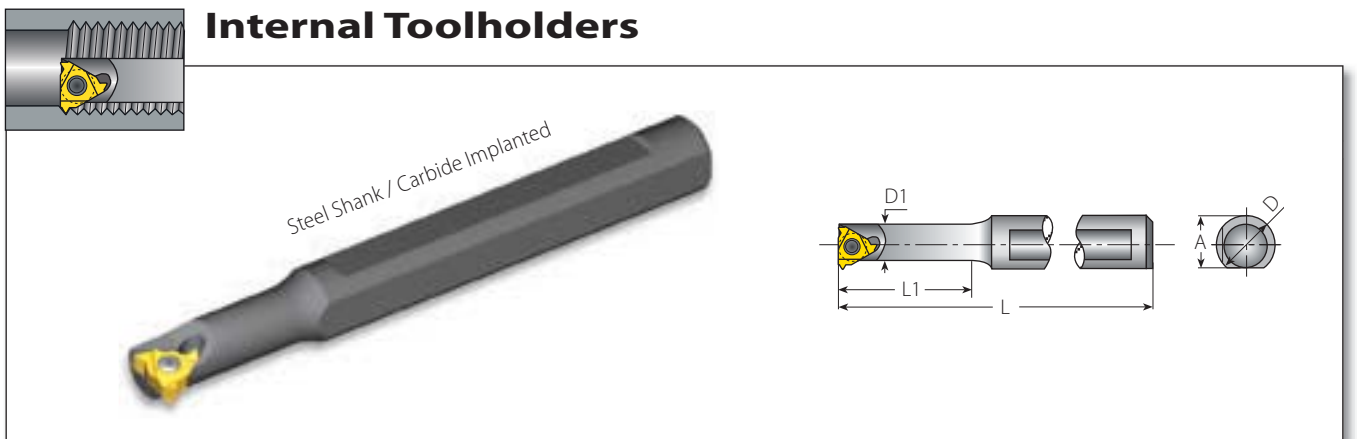

Mini-3 Standard

Insert Size		Ordering Code	Dimensions mm				Anti-Vibration System	Spare Parts	
IC	RH/LH	A	L	L1	D	D1		Insert Screw	Torx Key
6.0	SNVR12U-6.0	11.4	82	16	12	8	No	SN6MT	K6MT
	BNVR10S-6.0	9.4	89	22	10	8	Carbide Implanted		
	BNVR10M-6.0	9.4	98	31	10	8	Carbide Implanted		
	BNVR10L-6.0	9.4	110	43	10	8	Carbide Implanted		

The above toolholders have 2.5° helix angle.
The above toolholders are for RH inserts. For LH inserts, add LH to the toolholder's ordering code (Example: NVRC8-5.0KULH).

Internal Toolholders

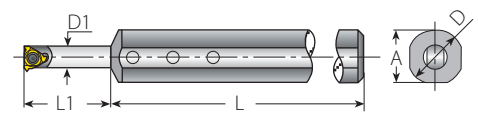
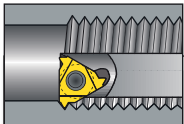

Mini-3 Adjustable

Spare Parts

Insert Size		Ordering Code	Dimensions mm					Spare Parts			
IC	Sleeve	Holder RH/LH	A	L	L1	D	D1	Insert Screw	Torx Key for Insert Screw	Holder Screw x3	Key for Holder Screw
6.0	SV16-8.0	BNVR8.0T-6.0	15.6	100	8-56	16	8	SN6MT	K6MT	S4.0	K2.0

Internal Toolholders

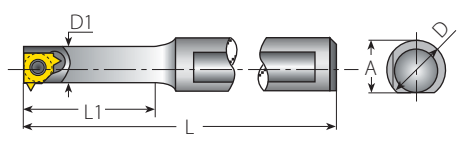
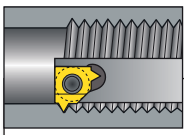

Mini-L

Spare Parts

Insert Size		Ordering Code	Dimensions mm				Anti-Vibration System	Spare Parts	
IC	RH/LH	A	L	L1	D	D1	Insert Screw	Torx Key	
5.0L	SNVR10U-5L	9.4	81	16	10	6.2	No	SN5LT	K5LT
	BNVR10S-5L	9.4	87	22	10	6.2	Carbide Implanted		
	BNVR10M-5L	9.4	97	31	10	6.2	Carbide Implanted		
	BNVR10L-5L	9.4	109	43	10	6.2	Carbide Implanted		

The above toolholders have 2.5° helix angle.
 The above toolholders are for RH inserts. For LH inserts, add LH to the toolholder's ordering code (Example: SNVR10U-5LLH).

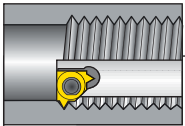

Internal Toolholders

MINIPRO



Thread Turning Toolholders

Mini-L-Adjustable

Spare Parts

Insert Size		Ordering Code		Dimensions mm					Spare Parts			
IC	Sleeve	Holder RH/LH	A	L	L1	D	D1	Insert Screw	Torx Key for Insert Screw	Holder Screw x 3	Key for Holder Screw	
5.0L	SV16-6.2	BNVR6.2T-5L	15.6	100	8-44	16	6.2	SN5LT	K5LT	S4.0	K2.0	

The above toolholders are for RH inserts. For LH inserts, add LH to the toolholder's ordering code (Example: BNVR6.2T-5L**LH**).

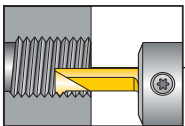

Internal Toolholders



Micro - Double Ended

Spare Parts

Micro Insert Dia.	Shank Dia.	Ordering Code	Dimensions mm			Location Screw (Every toolholder package contains the full range of location screws needed)		Key	Clamping Screw x 3	
			L	L1	L0	Screw	M		Screw	Key
3	10	SMC10-3.0	80	9- Short	89	AGISM8X28	28	K4.0	M4X0.7X4.0	K2.0
	12	SMC12-3.0		16- Medium	96	AGISM8X21	21			
	16	SMC16-3.0	95	9- Short	104	AGISM8X49	49			
	20	SMC20-3.0		16- Medium	111	AGISM8X42	42			
4	10	SMC10-4.0	80	9- Short	89	AGISM8X28	28			
	12	SMC12-4.0		16- Medium	96	AGISM8X21	21			
	16	SMC16-4.0	95	9- Short	104	AGISM8X49	49			
	20	SMC20-4.0		16- Medium	111	AGISM8X42	42			
6	12	SMC12-6.0	80	9- Short	89	AGISM8X28	28			
				16- Medium	96	AGISM8X21	21			
				21- Long	101	AGISM8X16	16			
	16	SMC16-6.0	95	9- Short	104	AGISM8X49	49			
20	SMC20-6.0	16- Medium		111	AGISM8X42	42				
				21- Long	116	AGISM8X37	37			

Internal Toolholders

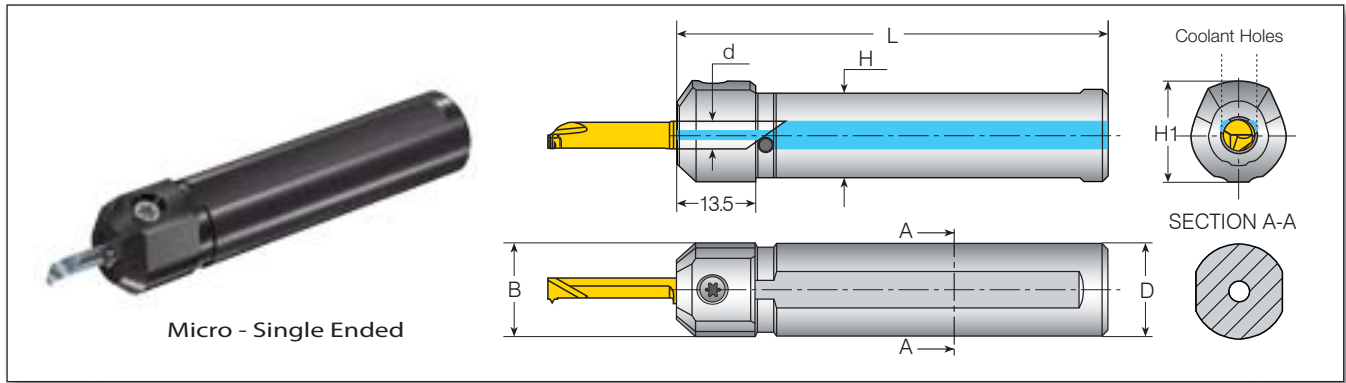

Thread Turning Toolholders





Micro - Single Ended

Round Shank - 2 Flats

Spare Parts

Micro Insert Dia.	Ordering Code	Dimensions mm					
d mm		D=B	H1	H	L	Clamping Screw	Torx Key
4.0	MHC10-4	10	14	8.8	65	SL7DT15	KT15
	MHC12-4	12	16	10.8	70		
	MHC16-4	16	17.6	14.8	75		
	MHC20-4	20	22	18.8	84		
5.0	MHC10-5	10	14	8.8	65		
	MHC12-5	12	16	10.8	70		
	MHC16-5	16	18.6	14.8	75		
	MHC20-5	20	22	18.8	84		
6.0	MHC12-6	12	16	10.8	70		
	MHC16-6	16	18.6	14.8	75		
	MHC20-6	20	22	18.8	84		
7.0	MHC16-7	16	18.6	14.8	75		
	MHC20-7	20	22	18.8	84		

Spare Parts

Micro Insert Dia.	Ordering Code	Dimensions (mm / inch)						
d (mm / inch)		D	B	H1	H	L	Clamping Screw	Torx Key
4.0 / .157	MHC0500-4	12.700 / .500	12.7 / .500	16.4 / .644	10.0 / .394	70.0 / 2.76	SL7DT15	KT15
	MHC0625-4	15.875 / .625	16.2 / .638	18.6 / .732	14.0 / .551	75.0 / 2.95		
	MHC0750-4	19.050 / .750	21.0 / .827	21.0 / .827	18.0 / .709	90.0 / 3.54		
5.0 / .197	MHC0500-5	12.700 / .500	12.7 / .500	16.4 / .644	10.0 / .394	70.0 / 2.76		
	MHC0625-5	15.875 / .625	16.2 / .638	18.6 / .732	14.0 / .551	75.0 / 2.95		
	MHC0750-5	19.050 / .750	21.0 / .827	21.0 / .827	18.0 / .709	90.0 / 3.54		
6.0 / .236	MHC0500-6	12.700 / .500	12.7 / .500	16.4 / .644	10.0 / .394	70.0 / 2.76		
	MHC0625-6	15.875 / .625	16.2 / .638	18.6 / .732	14.0 / .551	75.0 / 2.95		
	MHC0750-6	19.050 / .750	21.0 / .827	21.0 / .827	18.0 / .709	90.0 / 3.54		
7.0 / .276	MHC0625-7	15.875 / .625	16.2 / .638	18.6 / .732	14.0 / .551	75.0 / 2.95		
	MHC0750-7	19.050 / .750	21.0 / .827	21.0 / .827	18.0 / .709	90.0 / 3.54		

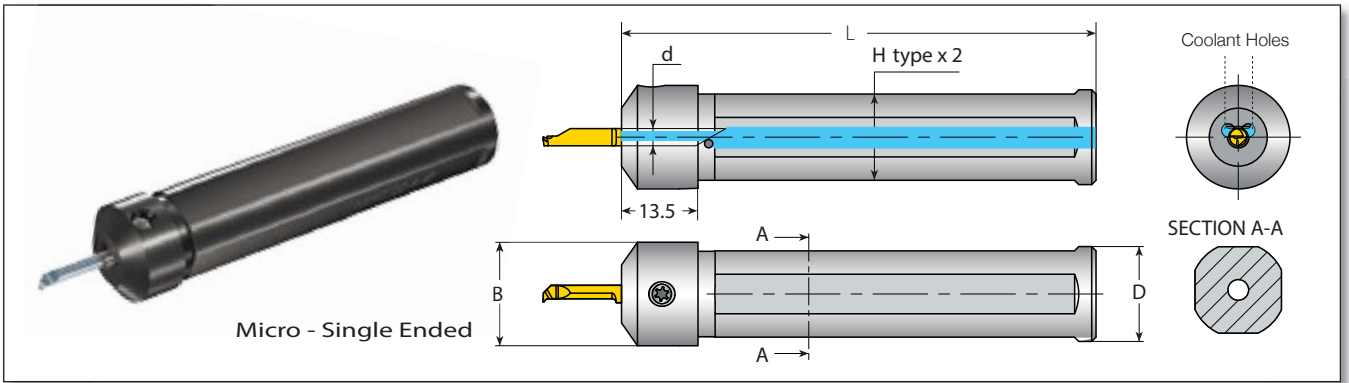

Round Shank - 4 Flats

Spare Parts

Micro Insert Dia.	Ordering Code	Dimensions mm					
d mm		D	B	H	L	Clamping Screw	Torx Key
4.0	MHC20-4-4F	20.0	22.0	18.8	83.5	SL7DT15	KT15
	MHC22-4-4F	22.0	24.0	20.0	110		
	MHC23-4-4F	23.0	25.0	21.0			
	MHC25-4-4F	25.0	27.0	23.0			
	MHC28-4-4F	28.0	30.0	26.0			
5.0	MHC20-5-4F	20.0	22.0	18.8	83.5		
	MHC22-5-4F	22.0	24.0	20.0	110		
	MHC23-5-4F	23.0	25.0	21.0			
	MHC25-5-4F	25.0	27.0	23.0			
	MHC28-5-4F	28.0	30.0	26.0			
6.0	MHC20-6-4F	20.0	22.0	18.8	83.5		
	MHC22-6-4F	22.0	24.0	20.0	110		
	MHC23-6-4F	23.0	25.0	21.0			
	MHC25-6-4F	25.0	27.0	23.0			
	MHC28-6-4F	28.0	30.0	26.0			
7.0	MHC22-7-4F	22.0	24.0	20.0	110		
	MHC23-7-4F	23.0	25.0	21.0			
	MHC25-7-4F	25.0	27.0	23.0			
	MHC28-7-4F	28.0	30.0	26.0			

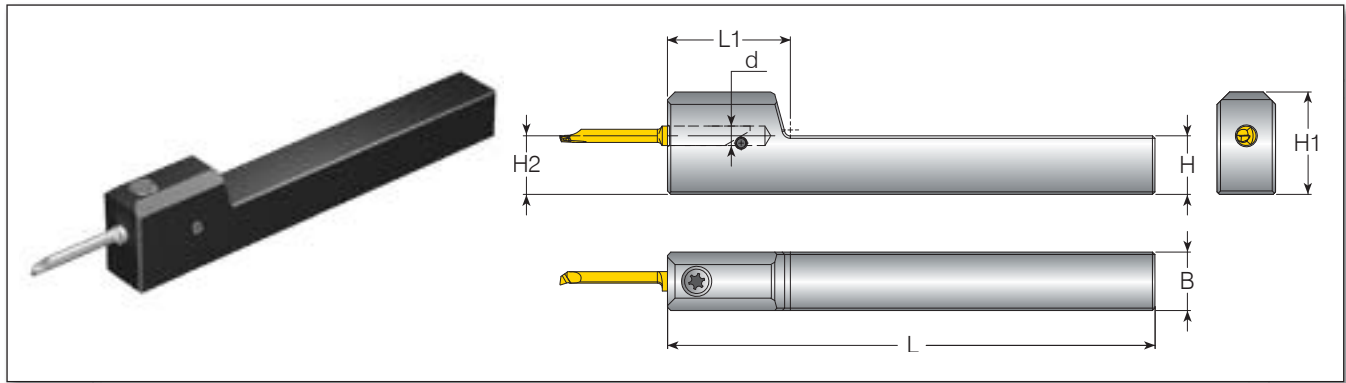

Spare Parts

Micro Insert Dia.	Ordering Code	Dimensions (mm / inch)					
d (mm / inch)		D	B	H	L	Clamping Screw	Torx Key
4.0 / .157	MHC0875-4-4F	22.2 / .875	23.5 / .925	20.83 / .82	84.0 / 3.29	SL7DT15	KT15
	MHC1000-4-4F	25.4 / 1.000	27.0 / 1.063	22.86 / .90	110.0 / 4.33		
5.0 / .197	MHC0875-5-4F	22.2 / .875	23.5 / .925	20.83 / .82	84.0 / 3.29		
	MHC1000-5-4F	25.4 / 1.000	27.0 / 1.063	22.86 / .90	110.0 / 4.33		
6.0 / .236	MHC1000-6-4F	25.4 / 1.000	27.0 / 1.063	22.86 / .90	110.0 / 4.33		





Microscope Holder with Square Shank

Spare Parts

Micro Insert Dia.	Ordering Code	Dimensions mm					
d mm		H=H2=B	H1	L	L1	Clamping Screw	Torx Key
4.0	MHS1010-4	10.0	19.0	100.0	25.0	SL7DT15	KT15
5.0	MHS1010-5	10.0	19.5	100.0	25.0		
4.0	MHS1212-4	12.0	21.0	100.0	25.0		
5.0	MHS1212-5	12.0	21.5	100.0	27.0		
6.0	MHS1212-6	12.0	22.0	100.0	27.0		

Spare Parts

Micro Insert Dia.	Ordering Code	Dimensions (mm / inch)					
d (mm / inch)		H=H2=B	H1	L	L1	Clamping Screw	Torx Key
4.0 / .157	MHS0500-4	12.7 / .500	21.0 / .827	101.6 / 4.00	25.0 / .984	SL7DT15	KT15
	MHS0625-4	15.9 / .625	25.0 / .984	127.0 / 5.00	25.0 / .984		
5.0 / .197	MHS0500-5	12.7 / .500	21.5 / .846	101.6 / 4.00	27.0 / 1.063		
	MHS0625-5	15.9 / .625	25.5 / 1.004	127.0 / 5.00	35.0 / 1.377		
6.0 / .236	MHS0500-6	12.7 / .500	22.0 / .866	101.6 / 4.00	27.0 / 1.063		
	MHS0625-6	15.9 / .625	26.0 / 1.024	127.0 / 5.00	35.0 / 1.377		
7.0 / .276	MHS0625-7	15.9 / .625	26.5 / 1.043	127.0 / 5.00	35.0 / 1.377		

Internal Toolholders

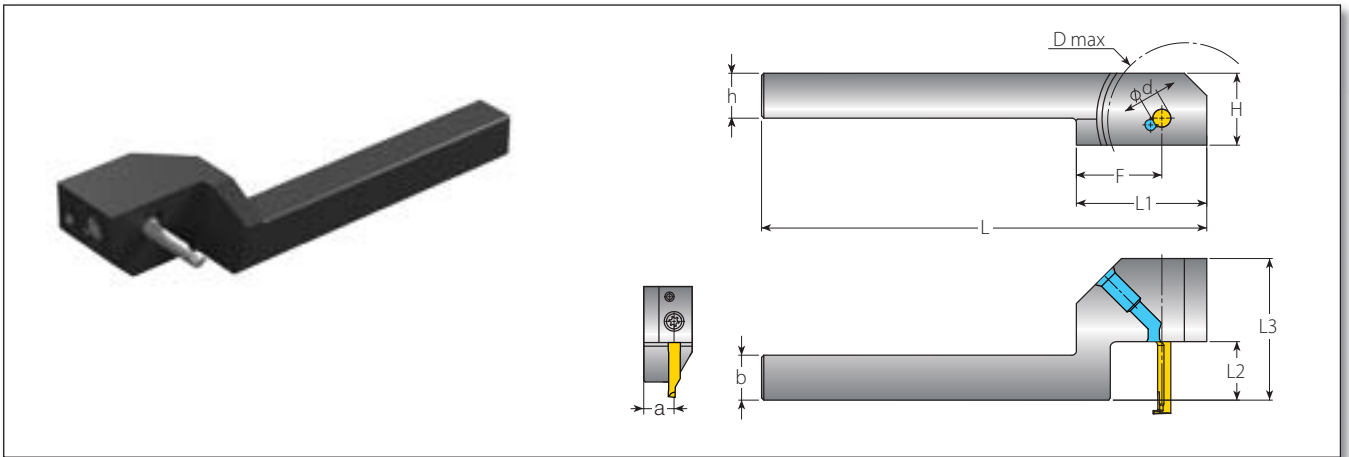

microscope



Thread Turning Toolholders

Microscope Holder with Drop Head

Spare Parts

Micro Insert Dia.	Ordering Code	Dimensions mm								Spare Parts	
d mm	a=b=h	L3	H	L	L1	F	D max	L2			
4.0	MHD0375-4L0700	36.5	16.0	99.0	29.0	19.0	26.0	18.0	SL7DT15	KT15	
5.0	MHD0375-5L0800	48.0						23.0			
6.0	MHD0375-6L0800	53.0						23.0			
4.0	MHD0500-4L0700	36.5	19.0	99.0	29.0	19.0	26.0	18.0	SL7DT15	KT15	
5.0	MHD0500-5L0800	48.0						23.0			
6.0	MHD0500-6L1000	53.0						28.0			
4.0	MHD1010-4L0500	31.5	16.0	99.0	29.0	19.0	26.0	13.0	SL7DT15	KT15	
5.0	MHD1010-5L0800	48.0						23.0			
6.0	MHD1010-6L1000	53.0						28.0			
4.0	MHD1212-4L0700	36.5	18.0	99.0	29.0	19.0	26.0	18.0	SL7DT15	KT15	
5.0	MHD1212-5L0800	48.0						23.0			
6.0	MHD1212-6L1000	53.0						28.0			

Thread Turning Kits



TT External + Internal Kit

TT External Kit

TT Internal Kit

TT External + Internal Kit

Ordering Code		Contents		
KHTT3EI-...	Holder External + Internal	10 x External Inserts	10 x Internal Inserts	Torx Key 
	AL20-3 AVRC20-3	3ERA60...	3IRA60...	K3T
		3ERG60...	3IRG60...	
		3ER11W...	3IR11W...	
		3ER14W...	3IR14W...	
		3ER1.0ISO...	3IR1.0ISO...	
		3ER1.25ISO...	3IR1.25ISO...	
		3ER1.5ISO...	3IR1.5ISO...	
		3ER2.0ISO...	3IR2.0ISO...	
		3ER2.5ISO...	3IR2.5ISO...	
3ER3.0ISO...		3IR3.0ISO...		

TT External Kit

Ordering Code		Contents	
KHTT3E-...	Holder External	10 x External Inserts	Torx Key 
	AL20-3	3ERA60...	K3T
		3ERG60...	
		3ER11W...	
		3ER14W...	
		3ER1.0ISO...	
		3ER1.25ISO...	
		3ER1.5ISO...	
		3ER2.0ISO...	
		3ER2.5ISO...	
3ER3.0ISO...			

TT Internal Kit



Ordering Code		Contents	
KHTT3I-...	Holder Internal	10 x Internal Inserts	Torx Key 
	AVRC 20-3	3IRA60...	K3T
		3IRG60...	
		3IR11W...	
		3IR14W...	
		3IR1.0ISO...	
		3IR1.25ISO...	
		3IR1.5ISO...	
		3IR2.0ISO...	
		3IR2.5ISO...	
3IR3.0ISO...			

Ordering Code Example: KHTT3I-VKX.
Additional kits are available by request.



Thread Turning Inserts Kits



TT External Insert Kit

Ordering Code	Contents	
KITT3E-...	10 x External Inserts	Torx Key  Insert Screw 
	3ERA60...	K3T SA3T
	3ERG60...	
	3ER11W...	
	3ER14W...	
	3ER1.0ISO...	
	3ER1.25ISO...	
	3ER1.5ISO...	
	3ER2.0ISO...	
	3ER2.5ISO...	
3ER3.0ISO...		

TT Internal Insert Kit

Ordering Code	Contents	
KITT3I-...	10 x External Inserts	Torx Key  Insert Screw 
	3IRA60...	K3T SA3T
	3IRG60...	
	3IR11W...	
	3IR14W...	
	3IR1.0ISO...	
	3IR1.25ISO...	
	3IR1.5ISO...	
	3IR2.0ISO...	
	3IR2.5ISO...	
3IR3.0ISO...		

Ordering Code Example: KITT3E-VKX.
Additional kits are available by request.



Thread Turning Technical Data

Thread Terminology

External Thread

A thread on the external surface of a cylinder screw or cone.

Depth of Thread

The distance between crest and root measured normal to the axis.

Pitch

The distance between two corresponding points on adjacent thread forms is measured parallel to the axis. This distance can be defined in either millimeters or by tpi (threads per inch).

Nominal Diameter

The diameter from which the diameter limits are derived by the application of deviation allowances and tolerances.

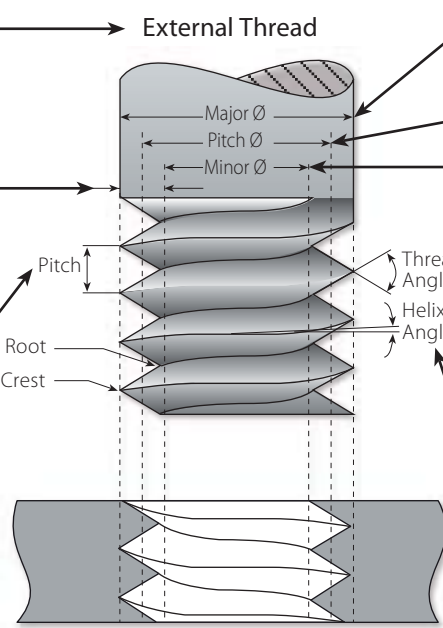

Major Diameter

The largest diameter of a screw thread.

Pitch Diameter

On a straight thread, the diameter of an imaginary cylinder, the surface of which cuts the thread forms where the width of the thread and groove are equal.

Minor Diameter

The smallest diameter of a screw thread.

Helix Angle

For a straight thread, where the lead of the thread and the pitch diameter circumference form a right angled triangle, the helix angle is the angle opposite the lead.

Straight Thread

A thread formed on a cylinder.

Taper Thread

A thread formed on a cone.

Left-hand thread

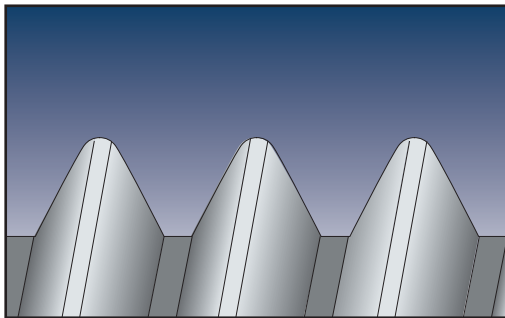

A thread which, when viewed axially, winds in a counterclockwise and receding direction. All left-hand threads are designated LH.

Right-hand thread

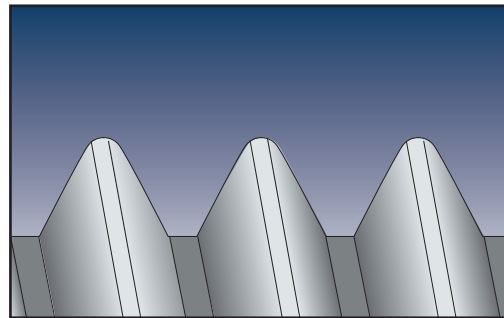

A thread which, when viewed axially, winds in a clockwise and receding direction. Threads are always right-hand unless otherwise specified.

The Helix Angle β

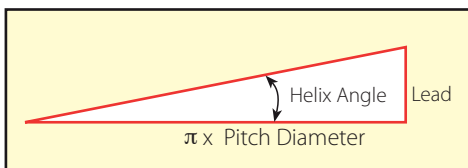

Lead

The distance a threaded part moves axially, with respect to a fixed mating part, in one complete revolution. The lead is equal to the pitch multiplied by the number of thread starts.

Machining a Multi-Start Thread

A thread in which the lead is an integral multiple, greater than one, of the pitch.
 A multi-start thread permits a more rapid advance without a coarser (larger) thread form.

First Start Machined

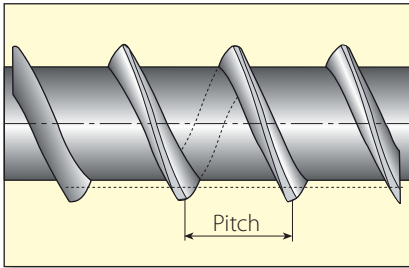

Second Start Machined

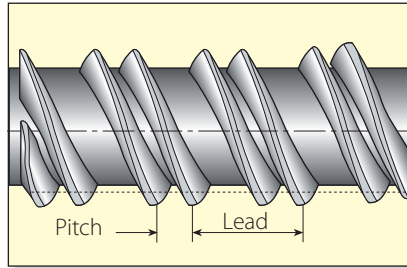

Third Start Machined
(Final, 3 Starts Thread)

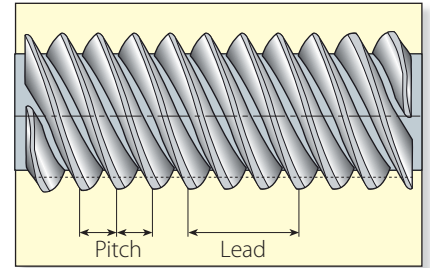

$$\text{Lead} = 3 \times \text{Pitch}$$

Insert Profile Styles

Partial Profile

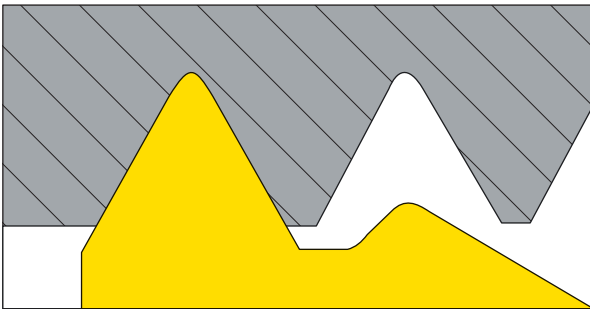

The V partial profile insert cuts without topping the outer diameter of the thread. The same insert can be used for a range of different thread pitches which have a common thread angle.

Full Profile

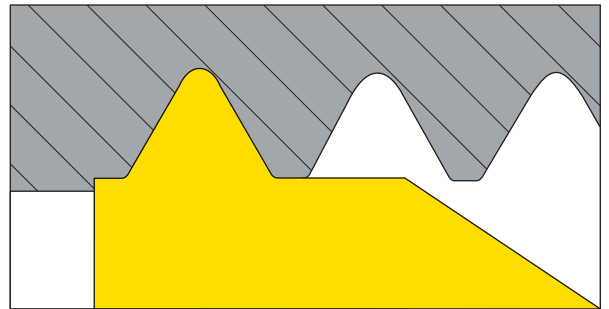

The full profile insert will form a complete thread profile including the crest. For every thread pitch and standard, a separate insert is required.

Full Profile for Fine Pitches

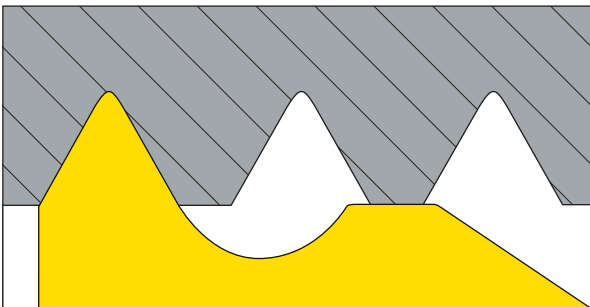

The full profile for Fine Pitches will form a complete thread. The topping of the outer diameter is generated by the second tooth.

Semi Full

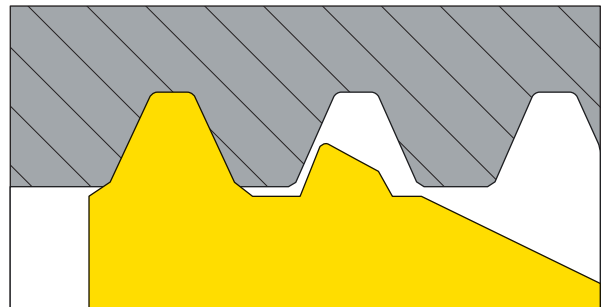

The Semi full profile insert will form a complete thread including crest radius but without topping the outer diameter. Mainly used for trapezoidal profiles.

Thread Turning Methods for Symmetrical Inserts

Thread	Inserts & Toolholder	Rotation	Feed Direction	Helix Method	Drawing No.
Right Hand External	EX RH	Counterclockwise	Towards chuck	Regular	1
	EX LH	Clockwise	From chuck	Reversed	2
Right Hand Internal	IN RH	Counterclockwise	Towards chuck	Regular	3
	IN LH	Clockwise	From chuck	Reversed	4
Left Hand External	EX LH	Clockwise	Towards chuck	Regular	5
	EX RH	Counterclockwise	From chuck	Reversed	6
Left Hand Internal	IN LH	Clockwise	Towards chuck	Regular	7
	IN RH	Counterclockwise	From chuck	Reversed	8

External RH Thread

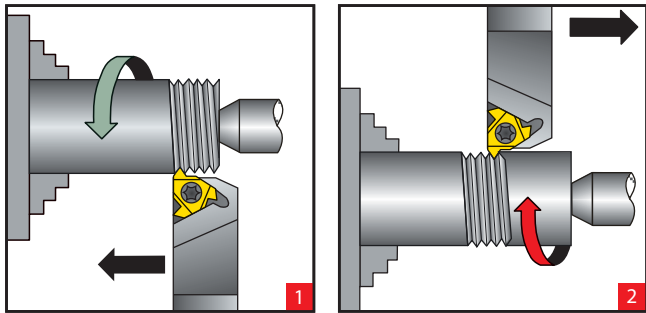

External LH Thread

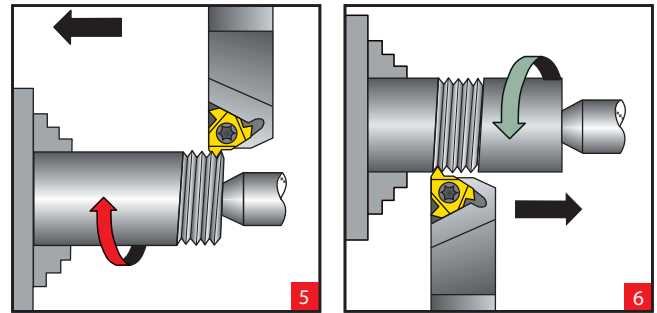

Internal RH Thread

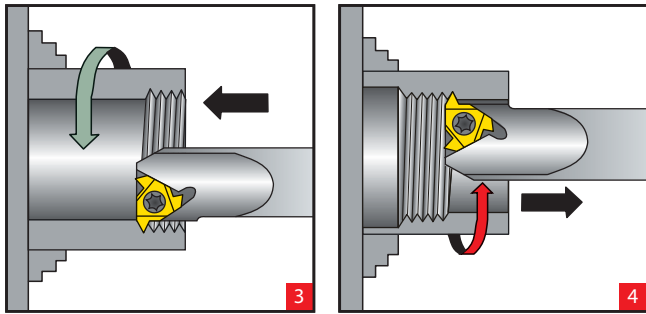

Internal LH Thread

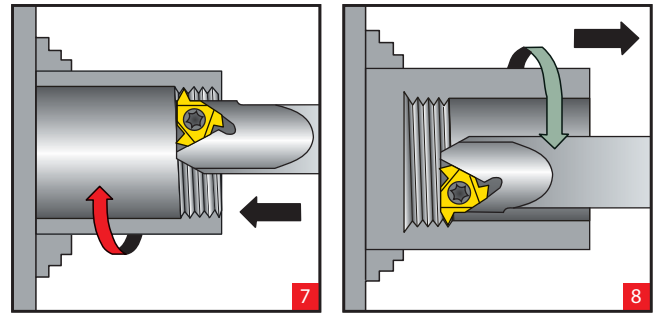

Thread Infeed Methods

Radial Infeed

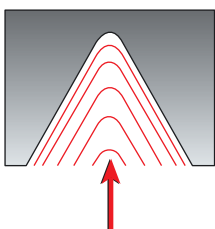

Radial infeed is the simplest and quickest method.

The feed is perpendicular to the turning axis, and both flanks of the insert perform the cutting operation.

Radial infeed is recommended in 3 cases:

- When the pitch is smaller than 16 tpi
- For material with short chips
- For work with hardened material

Flank Infeed (modified)

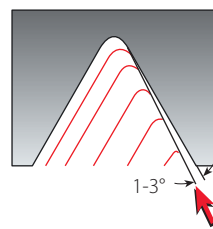

Flank infeed is recommended in the following cases:

- When the thread pitch is greater than 16 tpi, using the radial method, the effective cutting edge length is too large, resulting in chatter.
- For TRAPEZ and ACME. The radial method result in three cutting edges, making chip flow very difficult.

Alternate Flank Infeed

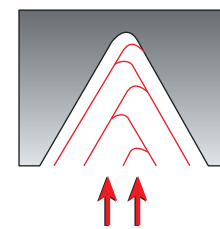

Use of the alternate flank method is recommended especially in large pitches and for materials with long chips. This method divides the load equally on both flanks, resulting in equal wear along the cutting edges. Alternate flank infeed requires more complicated programming, and is not available on all lathes.

Thread Turning Methods for Asymmetrical Inserts (ABUT, BBUT, SAGE)

Thread	Inserts & Toolholder	Rotation	Feed Direction	Helix Method	Drawing No.
Right Hand External	EX RH	Counterclockwise	Towards chuck	Regular	1
	EX LH	Clockwise	From chuck	Reversed	2
Right Hand Internal	IN RH	Counterclockwise	Towards chuck	Regular	3
	IN LH	Clockwise	From chuck	Reversed	4
Left Hand External	EX LH	Clockwise	Towards chuck	Regular	5
	EX RH	Counterclockwise	From chuck	Reversed	6
Left Hand Internal	IN LH	Clockwise	Towards chuck	Regular	7
	IN RH	Counterclockwise	From chuck	Reversed	8

Thread Turning
Technical Data

External RH Thread

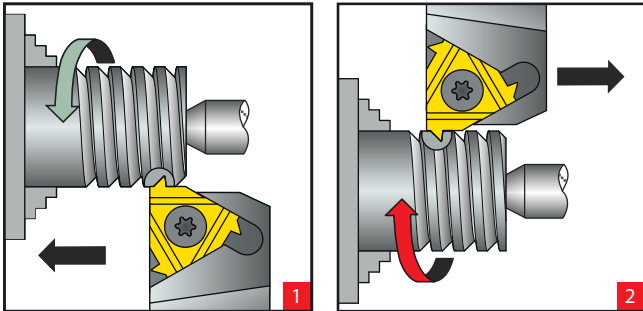

External LH Thread

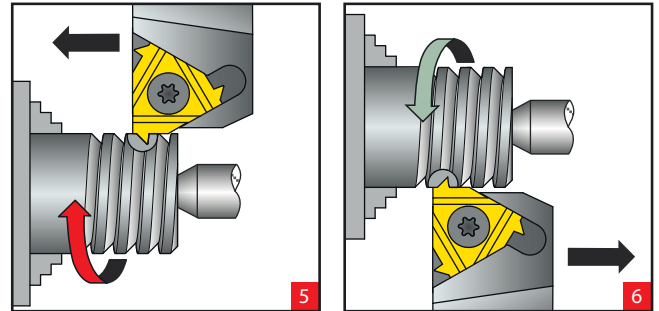

Internal RH Thread

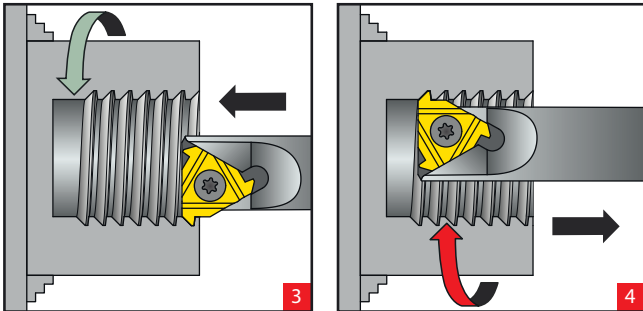

Internal LH Thread

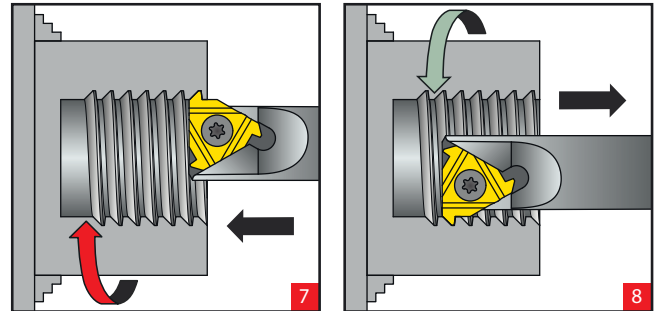

Calculating the Helix Angle and Choosing The Right Anvil

Flank Clearance Angle α (For External Inserts)

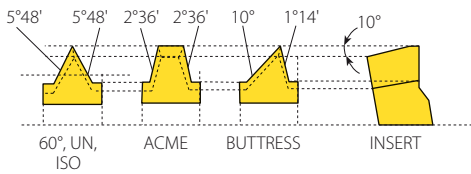

Vardex toolholders are designed to tilt the insert when seated in the toolholder (10° for external, 15° for internal tooling). This results in the differing flank clearance angles, based on the geometry of the insert. To ensure that the side of the insert cutting edge will not rub on the workpiece, it is most important that the insert helix angle be correct - especially in profiles with small enclosed flank angles. This correction is provided by Vardex anvils.

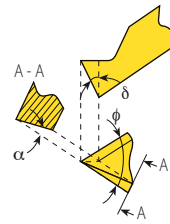

$$\alpha = \arctan(\tan \frac{\phi}{2} \times \tan \delta)$$

Where: α - Flank clearance angle
 δ - Tilt angle
 ϕ - Enclosed flank angle

the geometry of the insert. To ensure that the side of the insert cutting edge will not rub on the workpiece, it is most important that the insert helix angle be correct - especially in profiles with small enclosed flank angles. This correction is provided by Vardex anvils.

Calculating the Helix Angle β

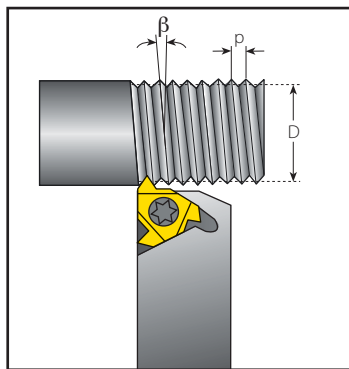

The helix angle is calculated by the following formula:

$$\beta = \arctan \frac{P \times N}{\pi \times D}$$

β - Helix angle [°]
 P - Pitch [mm]
 N - No. of starts
 D - Pitch diameter [mm]
 Lead = P x N

The helix angle can also be found from the diagram below.

Helix Angle Diagram

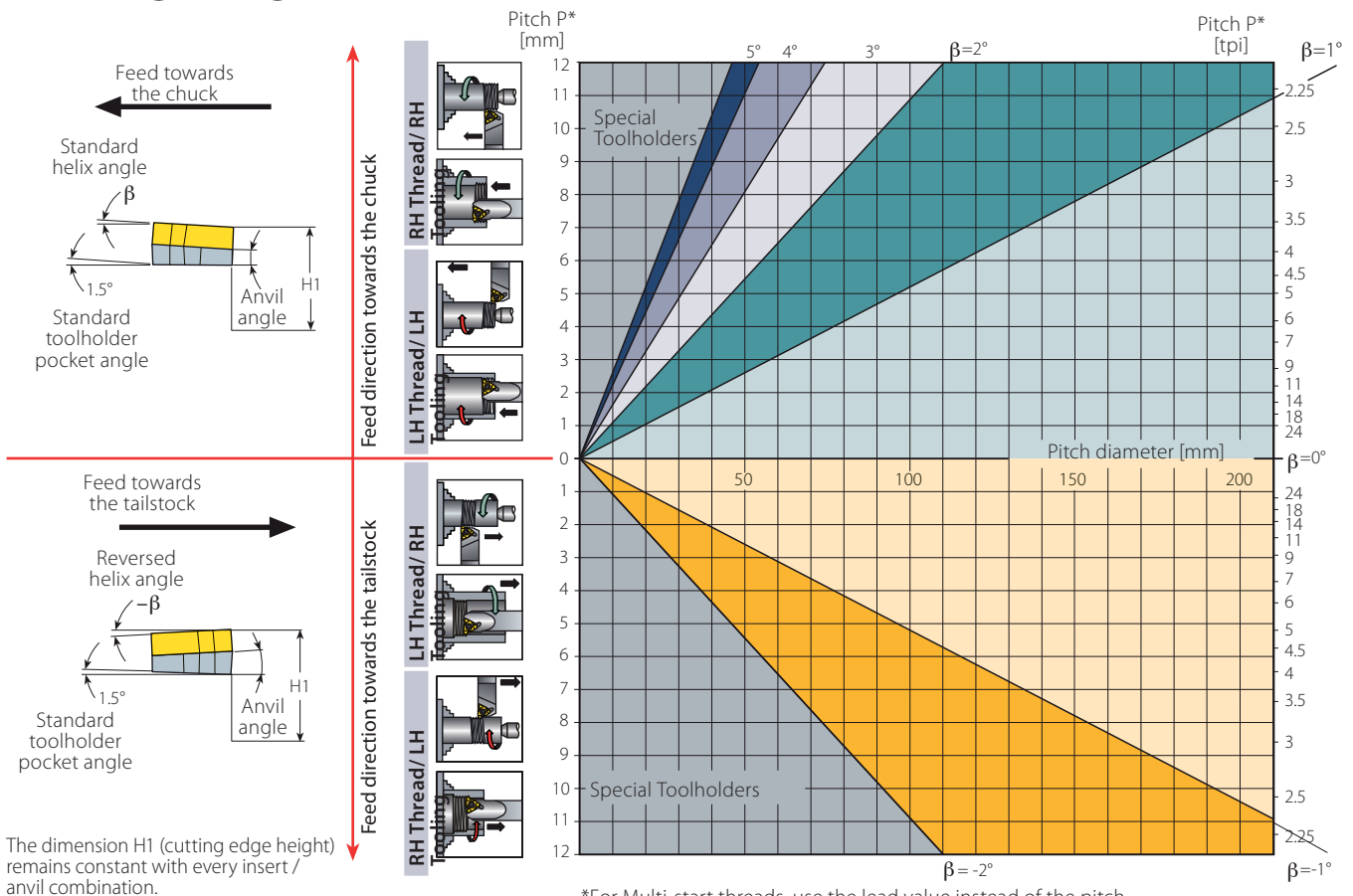

Anvils

Resultant Helix Angle		4.5°	3.5°	2.5°	1.5°	0.5°	0°	-0.5°	-1.5°	
Insert Size	Holder	Ordering Code								
IC	L mm									
3/8"	16	ER / IL	YE3-3P	YE3-2P	YE3-1P	YE3	YE3-1N	YE3-1.5N	YE3-2N	YE3-3N
		EL / IR	YI3-3P	YI3-2P	YI3-1P	YI3	YI3-1N	YI3-1.5N	YI3-2N	YI3-3N
3/8" V6	16	ER	YE3-6C-3P	YE3-6C-2P	YE3-6C-1P	YE3-6C	YE3-6C-1N	YE3-6C-1.5N	YE3-6C-2N	YE3-6C-3N
		IR	YI3-6C-3P	YI3-6C-2P	YI3-6C-1P	YI3-6C	YI3-6C-1N	YI3-6C-1.5N	YI3-6C-2N	YI3-6C-3N
1/2"	22	ER / IL	YE4-3P	YE4-2P	YE4-1P	YE4	YE4-1N	YE4-1.5N	YE4-2N	YE4-3N
		EL / IR	YI4-3P	YI4-2P	YI4-1P	YI4	YI4-1N	YI4-1.5N	YI4-2N	YI4-3N
1/2"F	23	ER	YE4F-3P	YE4F-2P	YE4F-1P	YE4F	YE4F-1N	YE4F-1.5N		
		IR	YI4F-3P	YI4F-2P	YI4F-1P	YI4F	YI4F-1N	YI4F-1.5N		
1/2"U	22	ER / IL	YE4U-3P	YE4U-2P	YE4U-1P	YE4U	YE4U-1N	YE4U-1.5N	YE4U-2N	YE4U-3N
		EL / IR	YI4U-3P	YI4U-2P	YI4U-1P	YI4U	YI4U-1N	YI4U-1.5N	YI4U-2N	YI4U-3N
5/8"	27	ER / IL	YE5-3P	YE5-2P	YE5-1P	YE5	YE5-1N	YE5-1.5N	YE5-2N	YE5-3N
		EL / IR	YI5-3P	YI5-2P	YI5-1P	YI5	YI5-1N	YI5-1.5N	YI5-2N	YI5-3N
5/8"U	27	ER / IL	YE5U-3P	YE5U-2P	YE5U-1P	YE5U	YE5U-1N	YE5U-1.5N	YE5U-2N	YE5U-3N
		EL / IR	YI5U-3P	YI5U-2P	YI5U-1P	YI5U	YI5U-1N	YI5U-1.5N	YI5U-2N	YI5U-3N
3/8"M+	16	ER / IL			YE3M-1P	YE3M	YE3M-1N	YE3M-1.5N	YE3M-2N	
		EL / IR			YI3M-1P	YI3M	YI3M-1N	YI3M-1.5N		
1/2"M+	22	ER / IL			YE4M-1P	YE4M	YE4M-1N	YE4M-1.5N	YE4M-2N	
		EL / IR			YI4M-1P	YI4M	YI4M-1N	YI4M-1.5N		
1/2"F 2M+	23	ER			YE4M2F-1P	YE4M2F	YE4M2F-1N	YE4M2F-1.5N		
1/2"F 3M+					YE4M3F-1P	YE4M3F	YE4M3F-1N	YE4M3F-1.5N		
1/2"F 2M+			IR			YI4M2F-1P	YI4M2F	YI4M2F-1N	YI4M2F-1.5N	
5/8"M+	27	ER / IL				YE5M	YE5M-1N	YE5M-1.5N		
		EL / IR				YI5M	YI5M-1N	YI5M-1.5N		
1/2"Z+	22	ER / IL			YE4Z-1P	YE4Z	YE4Z-1N			
		EL / IR			YI4Z-1P	YI4Z	YI4Z-1N			
5/8"Z+	27	ER / IL				YE5Z				
		EL / IR				YI5Z				
1/2"T+	22	ER / IL EL / IR					Y4T			

Thread Turning
Technical Data











Standard Anvil		V6 Anvil		U Style Anvil		M+ Style Anvil		Z+ Style Anvil		T+ Style Anvil	
ER/IL	EL/IR	ER	IR	ER/IL	EL/IR	ER/IL	EL/IR	ER/IL	EL/IR	ER/IL	EL/IR
		V6 is indicated on the backside								Same anvil turned over	

FLINE Anvil		FLINE M+ Style Anvil	
ER	IR	ER	IR

Oil&Gas - Anvils

Resultant Helix Angle	3°	2°	1°	0°	0.5°
Insert Size					
3/8" APIRD			YEI3-APIRD		
1/2" API	YEI4-API-3P	YEI4-API-2P	YEI4-API-1P		
1/2" BUT					YEI4-BUT-0.5N

Oil&Gas - 14D Anvils

Standard	Application	Anvils with Protected Second Cutting Edge			
		Ordering Code External Application		Ordering Code Internal Application	
API Round Casing & Tubing	10 tpi from Ø 2 3/8" and up	Y14DER-10APIRD (4 teeth)		Y14DIR-10APIRD (4 teeth)	
	10 tpi from Ø 2 3/8" and up	Y14DER10APIRD-3+ (3 teeth)		Y14DIR10APIRD-3+ (3 teeth)	
	8 tpi from Ø 2 3/8" and up	Y14DER-8APIRD		Y14DIR-8APIRD	
API Buttress Casing	5 tpi for Ø 4 1/2" - Ø 9 5/8"	Y14DER-5 BUT		Y14DIR-5 BUT	
	5 tpi for Ø 10 3/4" and up	Y14DER-5BUT-0.4N		Y14DIR-5BUT-0.4N	

Anvil Kits

Anvil Size		Ordering Code	Included Anvils:
IC	L mm		
3/8"	16	ABY3	YE3-2P, 1P, 1N, 2N, 3N
			YI3-2P, 1P, 1N, 2N, 3N
3/8" V6	16	ABY3-6C	YE3-6C-2P, 1P, 1N, 2N, 3N
			YI3-6C-2P, 1P, 1N, 2N, 3N
1/2"	22	ABY4	YE4-2P, 1P, 1N, 2N, 3N
			YI4-2P, 1P, 1N, 2N, 3N
1/2"U	22	ABY4U	YE4U-2P, 1P, 1N, 2N, 3N
			YI4U-2P, 1P, 1N, 2N, 3N
5/8"	27	ABYE5	YE5-2P, 1P, 1N, 2N, 3N
		ABYI5	YI5-2P, 1P, 1N, 2N, 3N
5/8"U	27	ABYE5U	YE5U-2P, 1P, 1N, 2N, 3N
		ABYI5U	YI5U-2P, 1P, 1N, 2N, 3N

To ensure that you always have on hand an assortment of anvils for any job, we recommend that anvil kits be readily available.

Important!

Use a V6 anvil when using a V6 insert.



For External RH
use YE3-6C anvil.

For Internal RH
use YI3-6C anvil.



Spare Parts

External and Internal Toolholders (not including Micro and Microscope)

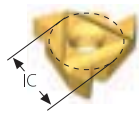

Insert Size



Insert Screw / Clamp Screw



Anvil Screw & Washer













Anvil

Toolholder	IC	Designation	Thread	Designation	Thread	Key	Torx size	EX RH/IN LH	IN RH/EX LH
Standard	1/4"	SN2T	M2.6x0.45x6.5	-	-	K2T	T8	-	-
	3/8", 3/8"V6	SA3T	5-40UNCx11.3	SY3T	UNC5x7.3	K3T	T10	YE3/YE3-6C	Y13/Y13-6C
	3/8"	SN3T	5-40UNCx8.8	-	-	K3T	T10	-	-
	1/2"	SA4T	8-32UNCx14.0	SY4T	UNC8x9.3	K4T	T20	YE4	Y14
	1/2"	SN4T	8-32UNCx11.0	-	-	K4T	T20	-	-
	1/2F"	SA4T	8-32UNCx14.0	SY4T	UNC8x9.3	K4T	T20	YE4F	Y14F
	5/8"	SA5T	M5x0.8x22.0	SY5T	M5x0.8x9.5	K5T	T25	YE5	Y15
Standard Coarse	3/8"	SN3TM	5-40UNCx7.3	-	-	K3T	T10	-	-
	1/2"	SN4TM	8-32UNCx9.8	-	-	K4T	T20	-	-
	5/8"	SN5TM	M5x0.8x13.9	-	-	K5T	T25	-	-
Standard with Clamp	3/8"	SA3T/C3	UNC5x12.0/M5x0.8x22.0	SY3T	UNC5x7.3	K3CT	T15/T10	YE3	Y13
	1/2"	SA4T/C4	UNC8x15.2/M6x1.0x29.5	SY4T	UNC8x9.3	K4T	T20	YE4	Y14
	5/8"	SA5T/C5	M5x0.8x22.0/M8x1.25x28.0	SY5T	M5x0.8x9.5	K5T	T25	YE5	Y15
U Style	1/2"U	SA4T	UNC8x15.2	SY4T	UNC8x9.3	K4T	T20	YE4U	Y14U
	5/8"U	SA5T	M5x0.8x22.0	SY5T	M5x0.8x9.5	K5T	T25	YE5U	Y15U
U Style with Clamp	1/2"	SA4T/C4	UNC8x15.2/M6x1.0x29.5	SY4T	UNC8x9.3	K4T	T20	YE4U	Y14U
	5/8"	SA5T/C5	M5x0.8x22.0/M8x1.25x28.0	SY5T	M5x0.8x9.5	K5T	T25	YE5U	Y15U
V Style	1/4"V	SN2T	M2.6x0.45x6.5	-	-	K2T	T8	-	-
	3/8"V	SN3TV	5-40UNCx6.7	-	-	K3T	T10	-	-
	1/2"V	SN4T	8-32UNCx11.0	-	-	K4T	T20	-	-
	5/8"V	SN6T	M6x1.0x29.0	-	-	K6T	T20	-	-
Mega Line	5/8"MG	S5MG	M5x0.8x16.0	-	-	K6T	T20	-	-
Z+ Style	1/2"Z	SA4T	UNC8x15.2	SY4T	UNC8x9.3	K4T	T20	YE4Z	Y14Z
	5/8"Z	SA5T	M5x0.8x22.0	SY5T	M5x0.8x9.5	K5T	T25	YE5Z	Y15Z
M+ Style	3/8"M	SA3T	UNC5x12.0	SY3T	UNC5x7.3	K3T	T10	YE3M	Y13M
	1/2"M	SA4T	UNC8x15.2	SY4T	UNC8x9.3	K4T	T20	YE4M	Y14M
	5/8"M	SA5T	M5x0.8x22.0	SY5T	M5x0.8x9.5	K5T	T25	YE5M	Y15M
T+ Style	1/2"T	SA4T	UNC8x15.2	SY4K2	UNC8x7.3	K4T/K2	T20/T8	Y4T	Y4T
API	5/8"	SA5T/C5	M5x0.8x22.0/M8x1.25x28.0	SY5T	M5x0.8x9.5	K5T	T25	YE5OIL	Y15OIL
API 14D	14D	SA5T	M5x0.8x22.0	M4x0.7x6.0 (14D)		K5T/KT15	T25/T15	Y14DER-...	Y14DIR-...
Mini-V	V08	SNV08	M2.6x0.45x8	-	-	K2T	T8	-	-
	V11	SNV11	M3.5x0.6x10	-	-	K3T	T10	-	-
	V14	SNV14	M4x0.7x12	-	-	KT15	T15	-	-
	V16	SNV16	M5x0.8x12	-	-	K4T	T20	-	-
Mini-L	5.0L	SN5LT	M2x0.4x4.1	-	-	K5LT	T5	-	-
Mini-3	4.0mm	SN4MT	M2x0.4x4.0	-	-	K6MT	T6	-	-
	5.0mm	SN5MT	M2x0.4x5.3	-	-	K6MT	T6	-	-
	6.0mm	SN6MT	M1.8x0.35x4.5	-	-	K6MT	T6	-	-
Mini Adjustable Holder	-	S4.0	M4x0.7x4.0	-	-	K2.0	-	-	-

For Micro and Microscope Toolholders see pages 187-191

Grades and Their Applications

General Use			
VRX	VTX		VKX
			
Premium multipurpose submicron grade for stronger wear resistance and improved productivity. AlTiN alloyed PVD coated.	General purpose grade with tough submicron substrate. Provides good fracture toughness in non-rigid cutting conditions. TiAlN coated.		General purpose grade, excellent in steel and stainless steel, recommended for rigid cutting conditions. Ground or sintered chipbreaker styles. TiN coated.
General Use	Stainless Steel	Non Ferrous, High Temperature Alloys and Titanium	
VCB	VM7	VK2	VK2P
			
Sintered chipbreaker with ground profile for machining materials with long chips. TiAlN coated.	Specialty grade for threading stainless steel. Multi-layer PVD coated.	Uncoated grade for non-ferrous, aluminum, high temperature and titanium alloys.	Highly-polished version of the VK2 uncoated grade for high quality surface finish in aluminum.
VG-Cut	Oil&Gas	General Use for Oil & Gas Materials	
VPG	VRXP	VTXP	VKXP
			
Sub-micron substrate for a wide range of applications. Excellent anti-fracture resistance. Highly recommended for medium to high cutting speeds. TiAlN coated.	Premium submicron grade with reinforced cutting edge for the oil & gas industry. Ideal for steel and stainless steel in unstable cutting conditions. AlTiN alloyed PVD coated.	Excellent all-purpose grade, tailor-made to the oil & gas industry with reinforced cutting edge. Recommended for non-rigid cutting conditions. TiAlN coated.	General purpose grade, excellent in steel and stainless steel, and highly recommended for rigid cutting conditions. Special design with reinforced cutting edge for the oil & gas industry. TiN coated.

MINIPRO

Micro Line	Mini 5L & Mini IC 6.0	Mini IC4.0, IC5.0 & Mini-V
VMX	VHX	VTX
		
General purpose carbide grade for Micro double-ended inserts. TiN coated.	HSS grade for Mini 5L and Mini 6.0 inserts. Recommended for very low cutting speeds. TiN coated.	Sub-micron grade for general machining in low and medium cutting speeds. Highly recommended for stainless steel. TiAlN coated
microscope	Mini 5L & Mini IC 6.0	Mini IC4.0, IC5.0 & Mini-V
VBX	VKP	VBX
		
General purpose carbide grade for microScope threading inserts. TiCN coated.	General purpose carbide grade for the Mini 5L and Mini 6.0 inserts. TiN coated.	Sub-micron grade for general machining in low and medium cutting speeds for Mini 4.0K, 5.0K and Mini-V lines. Highly recommended for steel. TiCN coated

Thread Turning Grades According to Product Lines

General

Insert Style	VRX	VTX	VKX	VCB	VM7	VK2	VK2P	VPG
TT inserts general	✓	✓	✓		✓	✓	✓	
SCB (Sintered Chipbreaker)			✓	✓				
V6			✓					
Mega Line			✓					
F line	✓	✓						
VG Cut								✓

Oil & Gas



Insert Style	VRX	VTX	VKX	VRXP	VTXP	VKXP
T+		✓	✓		✓	✓
14D	✓	✓	✓	✓	✓	✓
CNGA		✓			✓	
On Edge		✓			✓	
Chaser		✓			✓	✓

MiniPro



Insert Style	VKP	VTX	VBX	VHX	VMX
Mini 4.0K, 5.0K		✓	✓		
Mini 5L, 6.0	✓			✓	
Mini-V		✓	✓		
Micro (Double Ended)					✓
Microscope (Single Ended)			✓		

Recommended Grades and Cutting Speeds Vc [m/min] Not Including MiniPro Line

Material Group	Vargus No.	Material	Hardness Brinell HB	Vc [m/min]					
				Coated				Uncoated	
				VKX(P)	VCB	VM7	VTX(P), VRX(P)	VK2(P)	
P Steel	1	Unalloyed Steel	Low Carbon (C=0.1-0.25%)	125	115-190	115-190		115-190	
	2		Medium Carbon (C=0.25-0.55%)	150	100-175	100-165		100-175	
	3		High Carbon (C=0.55-0.85%)	170	90-165	90-155		90-165	
	4	Low Alloy Steel (alloying elements≤5%)	Non Hardened	180	100-180	100-180		100-180	
	5		Hardened	275	75-140	75-140		75-140	
	6		Hardened	350	70-135	70-135		70-135	
	7	High Alloy Steel (alloying elements>5%)	Annealed	200	80-120	80-120		80-120	
	8		Hardened	325	50-100	50-100		50-100	
	9	Cast Steel	Low Alloy (alloying elements <5%)	200	70-130	70-130		70-130	
	10		High Alloy (alloying elements >5%)	225	60-120	60-120		60-120	
M Stainless Steel	11	Stainless Steel Ferritic	Non Hardened	200	70-130	70-130	70-150	70-130	
	12		Hardened	330	60-115	50-95	60-125	60-115	
	13	Stainless Steel Austenitic	Austenitic	180	90-140	80-120	90-160	90-140	
	14		Super Austenitic	200	40-110	30-100	40-120	40-110	
	15	Stainless Steel Cast Ferritic	Non Hardened	200	90-120	90-120	90-150	90-120	
	16		Hardened	330	65-110	65-110	65-120	65-110	
	17	Stainless Steel Cast Austenitic	Austenitic	200	85-110	85-110	85-120	85-110	
	18		Hardened	330	60-100	60-100	60-110	60-100	
K Cast Iron	28	Malleable Cast Iron	Ferritic (short chips)	130	60-70	70-120		60-70	
	29		Pearlitic (long chips)	230	60-145	70-120		60-145	
	30	Grey Cast Iron	Low Tensile Strength	180	70-130	70-130		70-130	
	31		High Tensile Strength	260	60-115	60-100		60-115	
	32	Nodular Sg Iron	Ferritic	160	125-160	125-160		125-160	
	33		Pearlitic	260	90-120	90-120		90-120	
N Non-Ferrous Metals	34	Aluminium Alloys Wrought	Non Aging	60	100-365	100-250		100-365	100-250
	35		Aged	100	80-220	80-180		80-220	80-160
	36	Aluminium Alloys	Cast	75	200-400	200-400		200-400	80-120
	37		Cast & Aged	90	200-280	200-280		200-280	70-100
	38	Aluminium Alloys	Cast Si 13-22%	130	60-180	60-150		60-180	50-120
	39	Copper and Copper Alloys	Brass	90	80-225	80-210		80-225	70-170
	40		Bronze And Non Leaded Copper	100	80-255	80-210		80-255	70-170
	S Heat Resistant Material	19	High Temperature Alloys	Annealed (iron based)	200	45-60	45-60		45-60
20		Aged (iron based)		280	30-50	30-50		30-50	25-40
21		Annealed (nickel or cobalt based)		250	20-30	20-30		20-30	20-30
22		Aged (nickel or cobalt based)		350	15-25	15-25		15-25	15-25
23		Titanium Alloys	Pure 99.5 Ti	400Rm	140-170	140-170		140-170	60-100
24			α+β Alloys	1050Rm	50-70	50-70		50-70	40-60
H Hardened Material	25	Extra Hard Steel	Hardened & Tempered	45-50HRc	45-60	45-60		45-60	
	26			51-55HRc	40-50	40-50		40-50	

$$N = \frac{1000 \times V_c}{\pi \times D}$$

$$V_c = \frac{N \times \pi \times D}{1000}$$

Calculation of N [RPM]

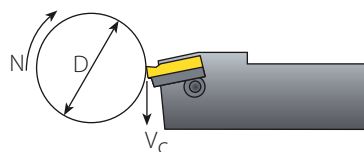

- N - Revolution Per Minute [RPM]
- V_c - Cutting Speed [m/min]
- D - Workpiece Diameter [mm]

Recommended Grades and Cutting Speeds Vc [m/min] Mini, Micro and Microscope

Material Group	Vargus No.	Material	Hardness Brinell HB	Vc [m/min]				
				Coated				
				VMX (Micro)	VBX (Microscope)	VKP/VBX VTX (Mini)	VHX (Mini)	
P Steel	1	Unalloyed Steel	Low Carbon (C=0.1-0.25%)	125	50-120	140-200	40-80	20-50
	2		Medium Carbon (C=0.25-0.55%)	150	40-100	120-180	40-80	15-40
	3		High Carbon (C=0.55-0.85%)	170	30-80	110-180	40-80	15-30
	4	Low Alloy Steel (alloying elements ≤5%)	Non Hardened	180	50-70	100-155	40-80	20-45
	5		Hardened	275	40-60	90-145	40-80	10-25
	6		Hardened	350	30-50	80-135	40-80	10-25
	7	High Alloy Steel (alloying elements >5%)	Annealed	200	30-50	65-115	40-60	
	8		Hardened	325	25-40	50-100	40-60	
	9	Cast Steel	Low Alloy (alloying elements <5%)	200	30-50	30-50	40-60	25-40
	10		High Alloy (alloying elements >5%)	225	25-40	25-40	40-60	25-40
M Stainless Steel	11	Stainless Steel Ferritic	Non Hardened	200	60-100	80-120	40-60	
	12		Hardened	330	40-60	55-95	40-60	
	13	Stainless Steel Austenitic	Austenitic	180	50-90	60-100	40-60	
	14		Super Austenitic	200	40-60	50-90	40-60	
	15	Stainless Steel Cast Ferritic	Non Hardened	200	40-60	60-80	40-60	
	16		Hardened	330	30-50	45-65	40-60	
	17	Stainless Steel Cast Austenitic	Austenitic	200	40-60	50-70	40-60	
	18		Hardened	330	30-50	40-60	40-60	
K Cast Iron	28	Malleable Cast Iron	Ferritic (short chips)	130	50-70	60-80	40-80	
	29		Pearlitic (long chips)	230	50-70	60-80	40-80	
	30	Grey Cast Iron	Low Tensile Strength	180	50-70	60-80	40-80	
	31		High Tensile Strength	260	40-60	40-70	40-80	
	32	Nodular Sg Iron	Ferritic	160	50-70	60-80	40-80	
	33		Pearlitic	260	60-80	70-90	40-80	
N Non-Ferrous Metals	34	Aluminium Alloys Wrought	Non Aging	60	100-300	80-240	40-120	30-60
	35		Aged	100	100-150	100-170	40-120	25-50
	36	Aluminium Alloys	Cast	75	100-150	100-150	40-120	25-50
	37		Cast & Aged	90	60-100	60-100	40-120	20-40
	38	Aluminium Alloys	Cast Si 13-22%	130	100-150	100-150	40-120	15-30
	39	Copper and Copper Alloys	Brass	90	60-100	80-200	40-120	15-35
	40		Bronze And Non Leaded Copper	100	60-100	80-200	40-120	15-35
	S Heat Resistant Material	19	High Temperature Alloys	Annealed (iron based)	200	25-45	25-45	30-45
20		Aged (iron based)		280	20-30	20-30	20-30	
21		Annealed (nickel or cobalt based)		250	15-20	15-20	15-20	
22		Aged (nickel or cobalt based)		350	10-15	10-15	15-20	
23		Titanium Alloys	Pure 99.5 Ti	400Rm	60-100	60-100	70-100	
24			α+β Alloys	1050Rm	40-50	40-50	40-50	
H Hardened Material	25	Extra Hard Steel	Hardened & Tempered	45-50HRc	20-40	20-40	20-40	
	26			51-55HRc	20-40	20-40	20-40	

Recommended Grades and Cutting Speeds Vc [m/min] VG-Cut

















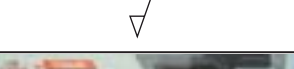

Material Group	Vargus No.	Material	Hardness Brinell HB	Vc [m/min]	
				VPG	
P Steel	1	Unalloyed Steel	Low Carbon (C=0.1-0.25%)	125	120-260
	2		Medium Carbon (C=0.25-0.55%)	150	90-220
	3		High Carbon (C=0.55-0.85%)	170	90-220
	4	Low Alloy Steel (alloying elements ≤5%)	Non Hardened	180	90-220
	5		Hardened	275	60-160
	6		Hardened	350	50-100
	7	High Alloy Steel (alloying elements >5%)	Annealed	200	90-220
	8		Hardened	325	50-100
	9	Cast Steel	Low Alloy (alloying elements <5%)	200	90-220
	10		High Alloy (alloying elements >5%)	225	60-160
M Stainless Steel	11	Stainless Steel Ferritic	Non Hardened	200	60-160
	12		Hardened	330	50-140
	13	Stainless Steel Austenitic	Austenitic	180	60-160
	14		Super Austenitic	200	60-160
	15	Stainless Steel Cast Ferritic	Non Hardened	200	60-160
	16		Hardened	330	50-140
	17	Stainless Steel Cast Austenitic	Austenitic	200	60-160
	18		Hardened	330	50-140
K Cast Iron	28	Malleable Cast Iron	Ferritic (short chips)	130	160-240
	29		Pearlitic (long chips)	230	140-220
	30	Grey Cast Iron	Low Tensile Strength	180	160-240
	31		High Tensile Strength	260	100-200
	32	Nodular Sg Iron	Ferritic	160	100-200
	33		Pearlitic	260	100-200
N Non-Ferrous Metals	34	Aluminium Alloys Wrought	Non Aging	60	200-450
	35		Aged	100	200-350
	36	Aluminium Alloys	Cast	75	200-450
	37		Cast & Aged	90	200-450
	38	Aluminium Alloys	Cast Si 13-22%	130	200-350
	39	Copper and Copper Alloys	Brass	90	200-450
	40		Bronze And Non Leaded Copper	100	200-450
S Heat Resistant Material	19	High Temperature Alloys	Annealed (iron based)	200	30-50
	20		Aged (iron based)	280	20-50
	21		Annealed (nickel or cobalt based)	250	20-50
	22		Aged (nickel or cobalt based)	350	20-50
	23	Titanium Alloys	Pure 99.5 Ti	400Rm	30-50
	24		α+β Alloys	1050Rm	30-70
H Hardened Material	25	Extra Hard Steel	Hardened & Tempered	45-50HRc	20-40
	26			51-55HRc	15-30

Recommended Grades, Cutting Speeds Vc [m/min] Mini-V

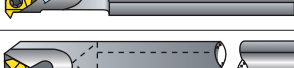
Material Group	Vargus No.	Material	Hardness Brinell HB	Vc [m/min]	
					VBX / VTX*
P Steel	1	Unalloyed Steel	Low Carbon (C=0.1-0.25%)	125	40-80
	2		Medium Carbon (C=0.25-0.55%)	150	40-80
	3		High Carbon (C=0.55-0.85%)	170	40-80
	4	Low Alloy Steel (alloying elements ≤5%)	Non Hardened	180	40-80
	5		Hardened	275	40-80
	6		Hardened	350	40-80
	7	High Alloy Steel (alloying elements >5%)	Annealed	200	40-60
	8		Hardened	325	40-60
	9	Cast Steel	Low Alloy (alloying elements <5%)	200	40-60
	10		High Alloy (alloying elements >5%)	225	40-60
M Stainless Steel	11	Stainless Steel Ferritic	Non Hardened	200	40-60
	12		Hardened	330	40-60
	13	Stainless Steel Austenitic	Austenitic	180	40-60
	14		Super Austenitic	200	40-60
	15	Stainless Steel Cast Ferritic	Non Hardened	200	40-60
	16		Hardened	330	40-60
	17	Stainless Steel Cast Austenitic	Austenitic	200	40-60
	18		Hardened	330	40-60
K Cast Iron	28	Malleable Cast Iron	Ferritic (short chips)	130	40-80
	29		Pearlitic (long chips)	230	40-80
	30	Grey Cast Iron	Low Tensile Strength	180	40-80
	31		High Tensile Strength	260	40-80
	32	Nodular Sg Iron	Ferritic	160	40-80
	33		Pearlitic	260	40-80
N Non-Ferrous Metals	34	Aluminium Alloys Wrought	Non Aging	60	40-120
	35		Aged	100	40-120
	36	Aluminium Alloys	Cast	75	40-120
	37		Cast & Aged	90	40-120
	38	Aluminium Alloys	Cast Si 13-22%	130	40-120
	39	Copper and Copper Alloys	Brass	90	40-120
	40		Bronze And Non Leaded Copper	100	40-120
S Heat Resistant Material	19	High Temperature Alloys	Annealed (iron based)	200	20-30
	20		Aged (iron based)	280	20-30
	21		Annealed (nickel or cobalt based)	250	15-20
	22		Aged (nickel or cobalt based)	350	10-15
	23	Titanium Alloys	Pure 99.5 Ti	400Rm	40-60
	24		α+β Alloys	1050Rm	20-30
H Hardened Material	25	Extra Hard Steel	Hardened & Tempered	45-50HRc	
	26			51-55HRc	

* Available for sizes V08 and V11. Sizes V14 and V16 are available upon request.

Cutting Conditions Parameters

Workpiece	Material Type	
	Material Dimension: Diameter and Length	
	Chipflow Character	
	Material Hardness	
Thread Application	External or Internal	
	Profile Shape	
	Surface Finish	
Machine	Machine Stability	
	Max. RPM	
	Clamping System Stability	
Coolant	Coolant Type	
Holders	Holder Cross Section Area	
	Holder Overhang	
	Through Coolant Option	
	Shank Type: Carbide, Alloy, Carbide Implant	
Insert	Grade	
	Profile Shape: Pitch and Depth	
	Nose Radius	
	Chipbreaker Style	

Number of Passes

Pitch	mm	0.50	0.75	1.00	1.25	1.50	1.75	2.00	2.50	3.00	3.50	4.00	4.50	5.00	5.50	6.00	8.00
	tpi	48	32	24	20	16	14	12	10	8	7	6	5.5	5	4.5	4	3
No. of passes		4-6	4-7	4-8	5-9	6-10	7-12	7-12	8-14	9-16	10-18	11-18	11-19	12-20	12-20	12-20	15-24
No. of passes (SCB)		3-4	3-4	3-5	4-6	5-6	6-8	6-8	8-10	9-12	10-14						
No. of passes (Micro / Microscope & Mini)		6-9	6-11	6-12	8-14	9-15	11-18	11-18									

Depths of Cut and Number of Passes for Mini-V

1. Intensive coolant is strongly recommended.
2. Infeed method - modified flank infeed 1°.
3. Number of passes can be decreased when high pressure cooling is used.

Option of modified volume chip

Mini-V

	Pitch mm	0.5	0.75	1	1.25	1.5	1.75	2	2.5	3	3.5	4				
	Pitch tpi	48	32	27	24	20	19	18	16	14	12	10	8	7	6	
Insert Style	Standard	Passes (modified volume)														
V08	ISO															
	UN	13	19		25	16			19	22						
	W															
	NPT															
	NPTF			28				43								
V11	ISO															
	UN	13	19		25	16			19	22	24					
	W															
	BSPT						19									
V14	ISO															
	UN	7	10		13	16			19	22	24	32	38			
	W															
V16	ISO															
	UN	7	10		13	16			19	22	24	32	38			
	W															

Option of constant depth chip

Mini-V

	Pitch mm	0.5	0.75	1	1.25	1.5	1.75	2	2.5	3	3.5	4				
	Pitch tpi	48	32	27	24	20	19	18	16	14	12	10	8	7	6	
Insert Style	Standard	Passes (same)														
V08	ISO															
	UN	11-24	17-35		23-48	18-28			21-34	25-40						
	W															
	NPT															
	NPTF			25-53				40-83								
V11	ISO															
	UN	11-24	17-35		23-48	14-28			17-34	20-40	23-46					
	W															
	BSPT						21-34									
V14	ISO															
	UN	11-24	17-35		23-48	14-28			9-15	11-18	11-18	12-21	18-24			
	W															
V16	ISO															
	UN	11-24	17-35		23-48	14-28			9-15	11-18	11-18	12-21	18-24			
	W															

Number of Passes and Depth of Cut per Pass for Multi+ Inserts



Standard	Insert Type		Insert Size		Pitch		Teeth	Ordering Code	Passes	Depth of cut per pass				
	IC	L mm								RH	1	2	3	4
ISO External	M+	3/8"	16	1.0	mm	3	3ER1.0ISO3M+...	2	0.32	0.30				
				1.5	mm	2	3ER1.5ISO2M+...	3	0.34	0.30	0.29			
				2.0	mm	2	3ER2.0ISO2M+...	3	0.45	0.40	0.38			
		1/2"	22	1.5	mm	3	4ER1.5ISO3M+...	2	0.48	0.45				
				2.0	mm	2	4ER2.0ISO2M+...	3	0.45	0.40	0.38			
				2.0	mm	3	4ER2.0ISO3M+...	2	0.64	0.59				
	5/8"	27	3.0	mm	2	5ER3.0ISO2M+...	4	0.46	0.42	0.38	0.36			
	T+	1/2" T	22	1.5	mm	8	4ER1.5ISO8T+...	1	0.93					
				2.0	mm	8	4ER2.0ISO8T+...	1	1.23					
	ISO Internal	M+	3/8"	16	1.0	mm	3	3IR1.0ISO3M+...	2	0.30	0.28			
					1.5	mm	2	3IR1.5ISO2M+...	3	0.31	0.28	0.27		
					2.0	mm	2	3IR2.0ISO2M+...	3	0.42	0.37	0.36		
1/2"			22	1.5	mm	3	4IR1.5ISO3M+...	2	0.45	0.41				
				2.0	mm	2	4IR2.0ISO2M+...	3	0.42	0.37	0.36			
				2.0	mm	3	4IR2.0ISO3M+...	2	0.59	0.56				
5/8"		27	3.0	mm	2	5IR3.0ISO2M+...	4	0.49	0.45	0.42	0.37			
T+		1/2"	22	1.5	mm	8	4IR1.5ISO8T+...	1	0.86					
				2.0	mm	8	4IR2.0ISO8T+...	1	1.15					
UN External		M+	3/8"	16	20	tpi	3	3ER20UN3M+...	2	0.41	0.38			
					18	tpi	2	3ER18UN2M+...	3	0.32	0.28	0.27		
					18	tpi	3	3ER18UN3M+...	2	0.45	0.42			
	16				tpi	2	3ER16UN2M+...	3	0.36	0.32	0.30			
	14				tpi	2	3ER14UN2M+...	3	0.43	0.38	0.37			
	12		tpi	2	3ER12UN2M+...	3	0.47	0.43	0.40					
	1/2"		22	16	tpi	3	4ER16UN3M+...	2	0.51	0.47				
				14	tpi	2	4ER14UN2M+...	3	0.43	0.38	0.37			
				12	tpi	2	4ER12UN2M+...	3	0.47	0.43	0.40			
		12		tpi	3	4ER12UN3M+...	2	0.67	0.63					
	11	tpi	2	4ER11UN2M+...	4	0.43	0.38	0.36	0.32					
	10	tpi	2	4ER10UN2M+...	4	0.46	0.42	0.40	0.36					
	5/8"	27	8	tpi	2	5ER8UN2M+...	4	0.56	0.50	0.48	0.41			
	UN Internal	M+	3/8"	16	12	tpi	2	3IR12UN2M+...	3	0.45	0.39	0.38		
					14	tpi	2	3IR14UN2M+...	3	0.41	0.36	0.34		
					16	tpi	2	3IR16UN2M+...	3	0.33	0.30	0.28		
			1/2"	22	16	tpi	3	4IR16UN3M+...	2	0.47	0.44			
					14	tpi	2	4IR14UN2M+...	3	0.41	0.36	0.34		
12					tpi	2	4IR12UN2M+...	3	0.45	0.39	0.38			
12		tpi	3	4IR12UN3M+...	2	0.63	0.59							
5/8"		27	8	tpi	2	5IR8UN2M+...	4	0.52	0.47	0.44	0.38			
BSW External		M+	3/8"	16	28	tpi	2	3ER28W2M+...	3	0.23	0.20	0.20		
	19				tpi	2	3ER19W2M+...	3	0.33	0.28	0.27			
	19				tpi	3	3ER19W3M+...	2	0.45	0.41				
	14				tpi	2	3ER14W2M+...	3	0.43	0.38	0.35			
	1/2"		22	14	tpi	3	4ER14W3M+...	2	0.60	0.56				
				11	tpi	2	4ER11W2M+...	4	0.44	0.38	0.36	0.30		

Thread Turning
Technical Data

Number of Passes and Depth of Cut per Pass for Multi+ Inserts



Standard	Insert Type	Insert Size		Pitch	Teeth	Ordering Code	Passes	Depth of cut per pass				
		IC	L mm					1	2	3	4	
BSW Internal	M+	3/8"	16	14	tpi	2	3R14W2M+...	3	0.43	0.38	0.35	
		1/2"	22	11	tpi	2	4R11W2M+...	4	0.44	0.38	0.36	0.30
NPT External	M+	3/8"	16	14	tpi	2	3ER14NPT2M+...	3	0.52	0.45	0.43	
		1/2"	22	11.5	tpi	2	4ER11.5NPT2M+...	4	0.46	0.43	0.42	0.40
		5/8"	27	11.5	tpi	3	5ER11.5NPT3M+...	4	0.48	0.43	0.42	0.38
	Z+	1/2"	22	11.5	tpi	2	4ER11.5NPT2Z+...	4	0.46	0.43	0.42	0.40
				8	tpi	2	4ER8NPT2M+...	4	0.72	0.64	0.60	0.53
		5/8"	27	8	tpi	2	5ER8NPT2M+...	4	0.72	0.64	0.60	0.53
NPT Internal	M+	3/8"	16	14	tpi	2	3R14NPT2M+...	3	0.52	0.45	0.43	
		1/2"	22	11.5	tpi	2	4R11.5NPT2M+...	4	0.46	0.43	0.42	0.40
		5/8"	27	11.5	tpi	2	5R11.5NPT3M+...	4	0.48	0.43	0.42	0.38
	Z+	1/2"	22	11.5	tpi	3	4R11.5NPT2Z+...	4	0.46	0.43	0.42	0.40
				8	tpi	2	4R8NPT2Z+...	4	0.72	0.64	0.60	0.53
		5/8"	27	8	tpi	2	5R8NPT2M+...	4	0.72	0.64	0.60	0.53
NPTF External	M+	3/8"	16	14	tpi	2	3ER14NPTF2M+...	3	0.51	0.44	0.42	
NPTF Internal	M+	3/8"	16	14	tpi	2	3R14NPTF2M+...	3	0.51	0.44	0.42	

Thread Turning
Technical Data

Oil&Gas API RD, API BUT, OTTM, OTTG

The following table provides the optimal cutting pass division options, depending on the material, machine stability and clamping conditions:

Application	No. of Passes/ Pass No.	1	2	3	4	5	6
APIRD 8 Ex, In	3 passes	0.89	0.81	0.11			
	4 passes	0.6	0.58	0.52	0.11		
	5 passes	0.47	0.47	0.43	0.33	0.11	
	6 passes	0.39	0.41	0.37	0.29	0.24	0.11
APIRD 10 Ex, In	3 passes	0.67	0.63	0.11			
	4 passes	0.44	0.45	0.41	0.11		
	5 passes	0.34	0.37	0.33	0.26	0.11	
	6 passes	0.28	0.32	0.29	0.22	0.19	0.11
BUT 5 Ex, In	3 passes	0.760	0.705	0.110			
	4 passes	0.506	0.501	0.458	0.110		
	5 passes	0.395	0.409	0.374	0.287	0.110	
	6 passes	0.329	0.353	0.324	0.249	0.210	0.110
OTTM 5 Ex, In OTTG 5 Ex, In	3 passes	0.760	0.730	0.110			
	4 passes	0.506	0.501	0.483	0.110		
	5 passes	0.395	0.409	0.374	0.312	0.110	
	6 passes	0.329	0.353	0.324	0.249	0.235	0.110

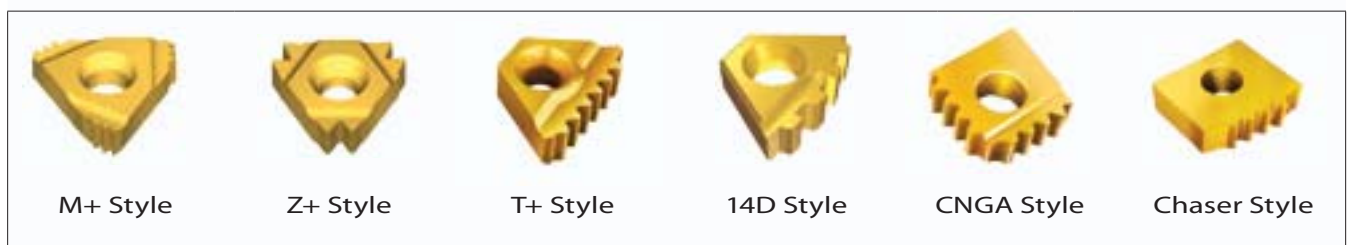

Cutting Speed Recommendations for Materials Specified by API STB 5

Material	J55-K55	N80-L80-C95-TN70	TN95-P110-TN110
Cutting Speed (m/min)	170-200	150-180	130-160

Step by Step Thread Turning - Example 1

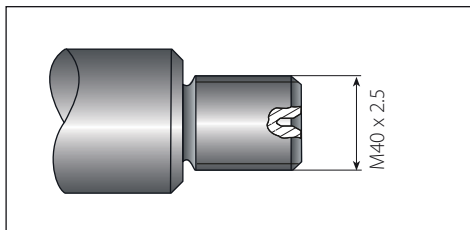

Application:
 Thread: External Right Hand
 ISO Metric M40x2.5
 Material: 4140 (25 HRC)

1 Choose the Thread Turning Method

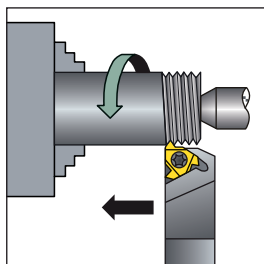

Feed direction towards the chuck was chosen.
 Therefore, an external right hand insert and an external right hand holder will be used.

2 Choose the Insert Size

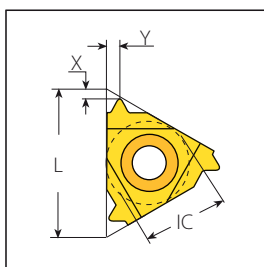

Chosen insert: 3ER2.5ISO

Insert Size	Pitch	Ordering Code	Anvil	Toolholder
IC	L mm	mm	RH	RH
3/8"	16	2.5	3ER2.5ISO...	YE3 AL..-3(LH)

3 Choose the Toolholder

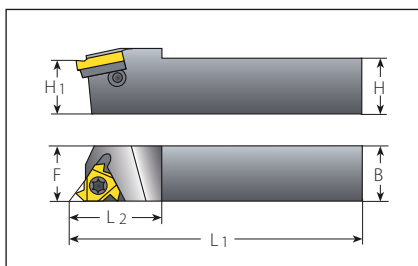

Chosen toolholder: AL 25-3

Insert Size	Ordering Code	Dimensions mm			
IC	RH	H=H1=B	F	L1	L2
3/8"	AL25-3	25	25	153.6	30

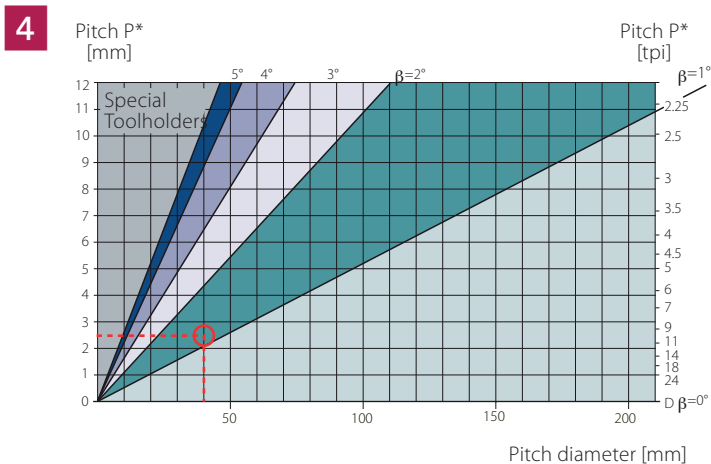

From the table, using a pitch of 2.5 mm (10 tpi) and a workpiece diameter of 40 mm (1.57"), we find the helix angle to be 1.5°.

5 Choose the Correct Anvil

Anvil chosen: YE3

Resultant Helix Angle

3.5

2.5

1.5

0.5

Insert Size	Ordering Code	Holder	Ordering Code			
IC	L mm					
3/8"	16	ER/IL	YE3-2P	YE3-1P	YE3	YE3-1N

6 Choose the Carbide Grade and Cutting Speed

Carbide Grade chosen: VTX

Cutting Speed: 140 m/min

Material:		Hardness Brinell HB	VTX	VCB	
P	Low alloy steel (alloying elements ≤ 5%)	Non hardened	180	85-145	100-180
		Hardened	275	75-140	75-140
		Hardened	350	70-135	70-135

7 Determine the Number of Passes

Number of passes: 14

ISO External

Pitch	mm	1.50	1.75	2.00	2.50	3.00	3.50	4.00
	tpi	16	14	12	10	8	7	6
No. of Passes		6-10	7-12	7-12	8-14	9-16	10-18	11-18

Summary

Thread Type	ISO M40x2.5 External Right Hand
1 Feed Direction:	Towards the chuck
2 Insert and Grade:	3ER2.5ISOVTX
3 Toolholder:	AL25-3
4 Helix Angle:	1.5°
5 Anvil:	YE3
6 Cutting Speed:	140 m/min
7 Number of Passes:	14

Step by Step Thread Turning - Example 2

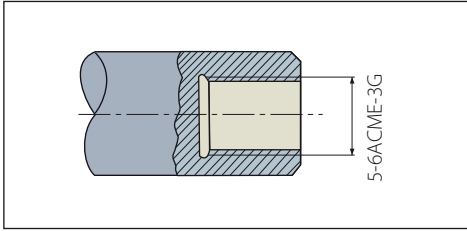

Application:
 Thread: Internal Right Hand
 ACME
 Pitch: 6 tpi
 Bore dia: 5"
 Material: Stainless Steel Austemitic

1 Choose the Thread Turning Method

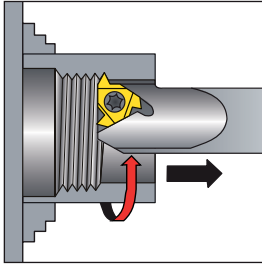

To facilitate the removal of chips from the machined area, we chose a feed direction away from the chuck. Therefore, an internal left hand insert and an internal left hand toolholder are to be used.

2 Choose the Insert Size

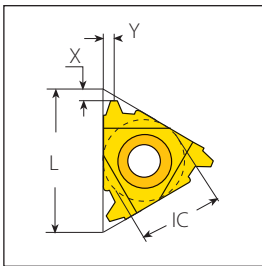

Chosen insert: 4IL6ACME

Insert Size	Pitch	Ordering Code	Anvil	Toolholder
IC	L mm	RH	LH	
1/2"	22	6	4IL6ACME...	YE4 AVR..-4(LH)

3 Choose the Toolholder

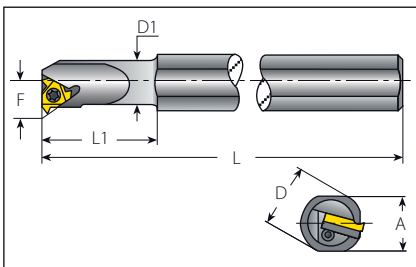

Chosen toolholder: AVR 40-4LH

Insert Size	Ordering Code	Dimensions mm						Min Bore
IC	RH	A	L	L1	D	D1	F	mm
1/2"	AVR 40-4	36.0	300	160	40	40.0	25.8	47

4 Determine the Helix Angle

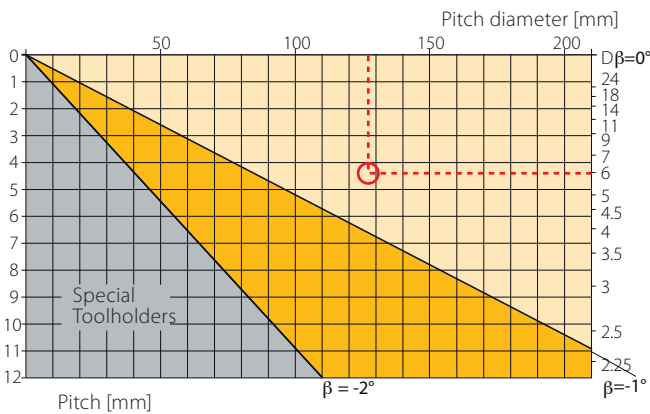

In this case, a right hand thread is being turned with a left hand toolholder. The reverse helix method is used. From the lower part of the table, using a pitch of 6 tpi and a bore diameter of 127mm, we obtain a helix angle of **-0.65°**.

5 Choose the Correct Anvil

Anvil chosen: YE4-2N

Insert Size		Ordering Code					
IC	L mm	ER/IL	YE4	YE4-1N	YE4-1.5N	YE4-2N	YE4-3N
1/2"	22	ER/IL	YE4	YE4-1N	YE4-1.5N	YE4-2N	YE4-3N

6 Choose the Carbide Grade and Cutting Speed

Carbide grade chosen: VTX
Cutting speed: 140 m/min

	Material:	Hardness Brinell HB	VTX	VCB
M	Stainless Steel Austenitic	Austenitic	180	90-140
		Super Austenitic	200	40-110
				80-120
				30-100

7 Determine the Number of Passes

Number of passes: 18

ACME External & Internal

Pitch	mm	3.00	3.50	4.00	4.50	5.00	5.50	6.00
	tpi	8	7	6	5.5	5	4.5	4
No. of Passes		9-16	10-18	11-18	11-19	12-20	12-20	12-20

Summary

Thread Type	5"x6 ACME Internal Right Hand
1 Feed Direction:	Away from the chuck
2 Insert and Grade:	4IL6ACMEVTX
3 Toolholder:	AVR40-4LH
4 Helix Angle:	-0.65°
5 Anvil:	YE4-2N
6 Cutting Speed:	140 m/min
7 Number of Passes:	18

Material Comparison Table

Material Group	VardeX No.	USA AISI/SAE	Germany W.-Nr.	Germany DIN	Great Britain BS	France AFNOR	Italy UNI
Steel	1	1015	1.0037	St37-2	Fe360B	E24-2	Fe360 B FU
	1	1020	1.0044	St44-2	Fe430B FN	E28-2	Fe430B FN
	2	ASTM A570Gr.50	1.0050	St50-2	Fe490-2 FN	A50-2	Fe490
	2	-	1.0070	St70-2	Fe690-2 FN	A70-2	Fe690
	1	1015	1.0401	C15	080M15	CC12	C15C16
	1	1020	1.0402	C22	050A20	CC20	C20C21
	2	1035	1.0501	C35	060A35	CC35	C35
	2	1045	1.0503	C45	080M46	CC45	C45
	2	1055	1.0535	C55	070M55	-	C55
	2	1060	1.0601	C60	080A62	CC55	C60
	1	1213	1.0715	95Mn28	230M07	S250	CF9SMn28
	1	12L13	1.0718	95MnPb28	-	S250Pb	CF9SMnPb28
	1	-	1.0722	10SPb20	-	10PbF2	CF10SPb20
	2	1140	1.0726	35S20	212M36	35MF4	-
	2	1215	1.0736	95Mn36	240M07	S300	CF9SMn36
	2	12L14	1.0737	95MnPb36	-	S300Pb	CF9SMnPb36
	2	9255	1.0904	55Si7	250A53	55S7	55Si8
	2	9262	1.0961	60SiCr7	-	60SC7	60SiCr8
	1	1015	1.1141	Ck15	080M15	XC1 2	C16
	2	1039	1.1157	40Mn4	150M36	35M5	-
	2	1025	1.1158	Ck25	-	-	-
	2	1335	1.1167	36Mn5	-	40M5	-
	2	1330	1.1170	28Mn6	150M28	20M5	C28Mn
	2	1035	1.1183	Cf35	060A35	XC38T5	C36
	2	1045	1.1191	Ck45	080M46	XC42	C45
	2	1055	1.1203	Ck55	070M55	XC55	C50
	3	1050	1.1213	Cf53	060A52	XC48T5	C53
	3	1060	1.1221	Ck60	080A62	XC60	C60
	8	1095	1.1274	Ck101	060A96	-	-
	9	-	1.3401	X120Mn12	Z120M12	Z120M12	XG120Mn12
	8	52100	1.3505	100Cr6	534A99	100C6	100Cr6
	8	ASTM A20Gr.A	1.5415	15Mo3	1501-240	15D3	16Mo3KW
	8	4520	1.5423	16Mo5	1503-245-420	-	16Mo5
	4	ASTMA350LF5	1.5622	14Ni6	-	16N6	14Ni6
	8	ASTM A353	1.5662	X8Ni9	1501-509; 510	-	X10Ni9
	8	2515	1.5680	12Ni19	-	Z18N5	-
	5	3135	1.5710	36NiCr6	640A35	35NC6	-
	5	3415	1.5732	14NiCr10	-	14NC11	16NiCr11
	5	3415; 3310	1.5752	14NiCr14	655M13; 655M12	12NC15	-
	5	9840	1.6511	36CrNiMo4	816M40	40NCD3	38NiCrMo4(KB)
	5	8620	1.6523	21NiCrMo2	805M20	20NCD2	20NiCrMo2
	5	8740	1.6546	40NiCrMo22	311-Type7	-	40NiCrMo2(KB)
	5	4340	1.6582	34CrNiMo6	817M40	35NCD6	35NiCrMo6(KB)
	5	-	1.6587	17CrNiMo6	820A16	18NCD6	-
	5	-	1.6657	14NiCrMo134	832M13	-	15NiCrMo13
	2	5015	1.7015	15Cr3	523M15	12C3	-
	5	5132	1.7033	34Cr4	530A32	32C4	34Cr4(KB)
	5	5140	1.7035	41Cr4	530M40	42C4	41Cr4
	5	5140	1.7045	42Cr4	-	-	-
	5	5115	1.7131	16MnCr5	(527M20)	16MC5	16MnCr5
5	5155	1.7176	55Cr3	527A60	55C3	-	
5	4130	1.7218	25CrMo4	1717CDS110	25CD4	25CrMo4(KB)	
5	4137; 4135	1.7220	34CrMo4	708A37	35CD4	35CrMo4	
5	4140; 4142	1.7223	41CrMo4	708M40	42CD4T5	41CrMo4	
5	4140	1.7225	42CrMo4	708M40	42CD4	42CrMo4	
5	-	1.7262	15CrMo5	-	12CD4	-	
5	ASTM A182; F11; F12	1.7335	13CrMo4 4	1501-620Gr.27	15CD3.5; 15CD4.5	14CrMo4 5	
5	-	1.7361	32CrMo12	722M24	30CD12	32CrMo12	
5	ASTM A182; F22	1.7380	10CrMo9 10	1501-622; Gr.31; 45	12CD9; 10	12CrMo9, 10	
5	-	1.7715	14MoV6 3	1503-660-440	-	-	
5	6150	1.8159	50CrV4	735A50	50CV4	50CrV4	
8	-	1.8509	41CrAlMo7	905M39	40CAD6, 12	41CrAlMo7	
8	-	1.8523	39CrMoV13 9	897M39	-	36CrMoV12	
5	W.110	1.1545	C105W1	-	Y1105	C98KU; C100KU	
5	W.112	1.1663	C125W	-	Y2120	C120KU	
8	L3	1.2067	100Cr6	BL3	Y100C6	-	
10	D3	1.2080	X210Cr12	BD3	Z200Cr12	X210Cr13KU	
10	-	-	-	-	-	X250Cr12KU	
10	-	1.2311	40CrMnMo7	-	-	35CrMo8KU	
10	-	1.2312	40CrMnMoS8-6	-	-	-	
10	H11	1.2343	X38CrMoV5-1	BH11	Z38CDV5	X37CrMoV51 1KU	
10	H13	1.2344	X40CrMoV5-1	BH13	Z40CDV5	X35CrMoV055KU	
10	-	-	-	-	-	X40CrMoV511KU	
10	A2	1.2363	X100CrMoV5-1	BA2	Z1 00CDV5	X100CrMoV51KU	
10	-	1.2367	X38CrMoV5-3	-	Z38CDV5-3	-	
10	D2	1.2379	X155CrVMo 12-1	BD2	Z160CDV12	X155CrVMo12 1 KU	
10	-	1.2419	105WCr6	-	105WC13	10WCr6; 107WCr5KU	
10	-	1.2436	X210CrW12	-	-	X215CrW121KU	
10	S1	1.2542	45WCrV17	BS1	-	45WCrV8KU	
10	H21	1.2581	X30WCrV9 3	BH21	Z30WCV9	X30WCrV9 3KU	
10	-	1.2601	X165CrMoV12	-	-	X165CrMoV12KU	
10	L6	1.2713	55NiCrMoV6	-	55NCDV7	-	
10	-	1.2738	40CrMnNiMo8-6-4	-	-	-	
10	W210	1.2833	100V1	BW2	Y1105V; 100V2	-	
10	-	1.3243	S 6-5-2-5	-	Z85WDCV-06-05-05-04-02	HS 6-5-2-5	
10	T4	1.3255	S 18-1-2-5	BT4	Z80WKCV-18-05-04-01	X78WCo1805KU	
10	M2	1.3343	S 6-5-2	BM2	Z85WDCV-06-05-04-02	X82WCo0605KU	
10	M7	1.3348	S 2-9-2	-	Z100WCWV-09-04-02-02	HS 2-9-2	
10	T1	1.3355	S 18-0-1	BT1	Z80WCV-18-04-01	X75W18KU	

Thread Turning Technical Data

Sweden SS	Japan JIS	Russia GOST	Spain UNE	Vardex No.
1311	STKM 12A;C	–	Fe360B	1
1412	SM400A;B;C	St4ps;sp	Fe430B FN	1
1550	SS490	St5ps;sp	A490-2	2
–	–	–	A690-2	2
1350	–	–	F.111	1
1450	–	20	1 C 22 ; F.112	1
1550	–	30	F. 113	2
1650	–	45	F.114	2
1655	–	55	F.115	2
–	–	60(G)	–	2
1912	SUM22	–	F.2111-11SMn28	1
1914	SUM22L	–	F.2112-11SMnPb28	1
–	–	–	F.2122-10SPb20	1
1957	–	–	F.210.G	2
–	–	–	F.2113-12SMn35	2
1926	–	–	F.2114-12SMnPb35	2
2085	–	55S2	F.1440-56Si7	2
–	–	–	F.1442-60SiCr8	2
1370	S15C	15	F.1110-C15k ; F.1511-C16k	1
–	–	40G	–	2
–	S25C	25	F.1120-C25k	2
2120	SMn438(H)	35G2 ; 35GL	F.1203-36Mn6 ; F.8212-36Mn5	2
–	SCM1	30G	28Mn6	2
1572	S35C	35	–	2
1672	S45C	45	F.1140-C45k ; F.1142-C48k	2
–	S55C	55	F.1150-C55k	2
1674	S50C	50	–	3
1678	S58C	60 ;60G ;60GA	–	3
1870	SUP4	–	–	8
–	SCMnH/1	110G13L	F.8251-AM-X120Mn12	9
2258	SUJ2	SchCh15	F.1310-100Cr6	8
2912	–	–	F.2601-16Mo3	8
–	–	–	F.2602-16Mo5	8
–	–	–	F.2641-15Ni6	4
–	–	–	F.2645-X8Ni09	8
–	–	–	–	8
–	SNC236	–	–	5
–	SNC415(H)	–	F.1540-15NiCr11	5
–	SNC81 5(H)	–	–	5
–	–	40ChN2MA ; 40ChGNM	F.1280-35NiCrMo4	5
2506	SNCM220(H)	20ChGNM	F.1552-20NiCrMo2 ; F.1534-20NiMo31	5
–	SNCM240	38ChGNM	F.1204-40NiCrMo2 ; F.1205-40NiCrMo2DF	5
2541	–	38Ch2N2MA	F.1272-40NiCrMo7 ; 34CrNiMo6	5
–	–	–	F.1560-14NiCrMo13	5
–	–	–	F.1560-14NiCrMo13 ; F.1569-14NiCrMo131	5
–	SCr415(H)	15Ch	–	2
–	SCr430(H)	35Ch	F.8221-35Cr4	5
–	SCr440(H)	40Ch	F.1211-41Cr4DF ; F.1202-42Cr4	5
2245	SCr440	40Ch	F.1202-42Cr4	5
2511	–	18ChG	F.1516-16MnCr5 ; F.1517-16MnCr5	5
–	SUP9(A)	50ChGA	F.1431-55Cr3	5
2225	SCM420	20ChM ; 30ChM	F.8372-AM26CrMo4;F.8330-AM25CrMo4;F.1256-30CrMo4-1	5
2234	SCM432; SCCRM3	AS38ChGM;35ChM;35ChML	F.8331-AM34CrMo4;F.823134CrMo4;F.1250-35CrMo4;F.1254-35CrMo4DF	5
2244	SCM440	40ChFA	F.8332-AM42CrMo4;F.8232-42CrMo4;F.1252-40CrMo4	5
2244	SCM440(H)	–	F.8332-AM42CrMo4;F.8232-42CrMo4;F.1252-40CrMo4	5
2216	SCM415(H)	–	F.1551-12CrMo4	5
–	–	12ChM ; 15ChM	F.2631-14CrMo45	5
2240	–	–	F.124.A	5
2218	–	12Ch8	TU.H	5
–	–	–	F.2621-13MoCrV6	5
2230	SUP10	50ChGFA ; 50ChFA	F.1430-51CrV4	5
2940	–	38ChMJuA	F.1740-41CrAlMo7	8
–	–	–	–	8
1880	–	U10A-1;2	F.516	5
–	SK2	U13	F.5123 ; C120	5
–	–	Ch	F.5230 ; 100Cr6	8
–	SKD1	Ch12	F.5212 ; X210 Cr12	10
–	–	–	–	10
–	–	–	–	10
–	–	–	–	10
–	SKD6	4ChMFS	F.5317 ; X37 CrMoV5	10
2242	SKD61	4ChMF1S	F.5318 ; X40CrMoC5	10
–	–	–	–	10
2260	SKD12	–	F.5227 ; X100CrMoV5	10
–	–	–	–	10
2310	SKD11	–	F.520A	10
2140	SKS31;SKS2,SKS3	ChWG	F.5233 ; 105WCr5	10
2312	SKD2	–	F.5213 ; X210CrW12	10
2710	–	5ChW2SF	F.5241 ; 45WCrSi8	10
–	SKD5	3Ch2W8F	F.5323 ; X30WCrV9	10
2310	–	–	F.5211 ; X160CrMoV12	10
–	SKT4	5ChNM	F.520S	10
–	–	–	–	10
–	SKS43	–	–	10
2723	SKH55	2723	R6MSK5	10
–	SKH3	–	F.5530 ; 18-1-1-5	10
2722	SKH9	(R6AM5) ; R6M5	F.5603 ; 6-5-2	10
2782	–	–	F.5607 ; 18-0-1	10
–	SKH2	R18	F.5520 ; 18-0-1	10

P

Material Comparison Table (con't)

Material Group	VarDEX No.	USA AISI/SAE	Germany W.-Nr.	Germany DIN	Great Britain BS	France AFNOR	Italy UNI
M Stainless Steel	12	403	1.4000	X6Cr13	403S17	Z6C13	X6Cr13
	12	-	1.4001	X7Cr14	-	-	-
	12	410	1.4006	X10Cr13	410S21	Z10C14	X12Cr13
	12	430	1.4016	X6Cr17	430S15	Z8C17	X8Cr17
	12	-	1.4027	G-X20Cr14	420C29	Z20C13M	-
	12	-	1.4034	X46Cr13	420S45	Z40CM;Z38C13M	X40Cr14
	12	431	1.4057	X20CrNi172	431S29	Z15CNi6.02	X16CrNi16
	12	430	1.4104	X12CrMoS17	-	Z10CF17	X10CrS17
	12	434	1.4113	X6CrMo171	434S17	Z8CD17.01	X8CrMo17
	12	-	1.4313	X5CrNi134	425C11	Z4CND13.4M	-
	12	-	1.4408	G-X6CrNiMo18 10	316C16	-	-
	12	HW3	1.4718	X45CrSi93	401S45	Z45CS 9	X45CrSi8
	12	405	1.4724	X10CrAl13	403S17	Z10C13	X101CrAl12
	11	-	1.4742	X10CrAl18	430S15	Z12CAS18	X8Cr17
	12	HNV6	1.4747	X80CrNiSi20	443S65	Z80CSN20.02	X80CrSiNi20
	11	446	1.4762	X10CrAl24	-	Z10CAS24	X16Cr26
	13	304	1.4301	X5CrNi18 10	304S15	Z6CN18.09	X5CrNi1810
	13	303	1.4305	X10CrNiSi18 9	303S21	Z10CNF 18.09	X10CrNiS 18.09
	13	304L	1.4306	X2CrNi19 11	304S12;304C12	Z2CN18.10;Z3CN 19.10	X2CrNi18.11
	13	CF8	1.4308	G-X6CrNi18 9	304C15	Z6CN18.10M	-
	13	301	1.4310	X12CrNi177	301S21	Z12CN 17.07	X1 2CrNi1 707
	13	304LN	1.4311	X2CrNiN18 10	304S62	Z2CN18.10	-
	13	316	1.4401	X5CrNiMo17122	316S16	Z6CND17.11	X5CrNiMo17 12
	13	316LN	1.4429	X2CrNiMoNi7133	-	Z2CND17.13	-
	13	316L	1.4435	X2CrNiMo18143	316S12	Z2CND17.13	X2CrNiMo17 13
	13	317L	1.4438	X2CrNiMo17133	317S12	Z2CND19.15	X2CrNiMo18 16
	13	329	1.4460	X8CrNiMo275	-	-	-
	12	321	1.4541	X6CrNiTi18 10	2337	Z6CNT18.10	X6CrNiTi18 11
	12	347	1.4550	X6CrNiNb18 10	347S17	Z6CNNb18.10	X6CrNiNb18 11
	12	316Ti	1.4571	X6CrNiMoTi17122	320S17	Z6NDT1 7.12	X6CrNiMoTi17 12
	12	-	1.4581	G-X5CrNiMoNb18 10	318C17	Z4CNDNb18 12M	XG8CrNiMo18 11
	12	318	1.4583	X10CrNiMoNb18 12	-	Z6CNDNb17 13B	X6CrNiMoNb17 13
	13	309	1.4828	X15CrNiSi20 12	309S24	Z15CNS20.12	-
	13	310S	1.4845	X12CrNi25 21	310S24	Z12CN25 20	X6CrNi25 20
	13	330	1.4864	X12NiCr36 16	-	Z12NCS35.16	-
	13	-	1.4865	G-X40NiCrSi38 18	330C11	-	XG50NiCr39 19
	13	EV8	1.4871	X53CrMnNiN2 19	349S54;321S12	Z52CMN21.09	X53CrMnNiN219
	13	321	1.4878	X12CrNiTi18 9	321S320	Z6CNT18.12B	X6CrNiTi1811
	30	No 20 B	0.6010	GG10	-	Ft 10 D	-
	30	No 25 B	0.6015	GG15	Grade 150	Ft 15 D	-
	30	No 30 B	0.6020	GG20	Grade 220	Ft 20 D	-
	29	No 35 B; No 40 B	0.6025	GG25	Grade 260	Ft 25 D	-
	29	No 45 B	0.6030	GG30	Grade 300	R 30 D	-
	29	No 50 B	0.6035	GG35	Grade 350	Ft 35 D	-
	29	No 55 B	0.6040	GG40	Grade 400	Ft 40 D	-
29	ASTM	-	DIN4694	3468: 1974	-	-	
29	A436-72	-	GGL-	-	A32-301	-	
29	Type 2	-	NiCr20 2	L-NiCr 20 2	L-NC 20 2	-	
30	60-40-18	0.7040	GGG 40	SNG 420/12	FCS 400-12	GS 370-17	
30	-	0.7043	GGG 40.3	SNG 370/17	FGS 370-17	-	
30	-	0.7033	GGG 35.3	-	-	-	
31	80-55-06	0.7050	GGG 50	SNG 500/7	FGS 500-7	GS 500	
31	-	0.7060	GGG 60	SNG 600/3	FGS 600-3	-	
31	100-70-03	0.7070	GGG70	SNG 700/2	FGS 700-2	GS 700-2	
31	-	-	DIN 1694	-	L-NM 13 7	-	
31	Type 2	-	GGG NiMn 13 7	L-NiMn 13 7	L-NC 20 2	-	
31	-	-	GGG NiCr 20 2	L-NC 20 2	-	-	
28	32510	0.8135	GTS-35	B 340/12	MN 35-10	-	
29	40010	0.8145	GTS-45	P 440/7	-	-	
29	50005	0.8155	GTS-55	P 510/4	MP50-5	-	
29	70003	0.8165	GTS-65	P 570/3	MP 60-3	-	
29	80002	0.8170	GTS-70	P690/2	MP 70-2	-	
36	-	-	G-AISI12	LM20	-	-	
36	-	-	GD-AISI12	-	-	-	
36	-	-	GD-AISI8Cu3	LM24	-	-	
36	-	-	G-AISI10Mg	LM9	-	-	
36	-	-	G-AISI12	LM6	-	-	
19	330	1.4864	X12NiCrSi	-	Z12NCS35.16	-	
19	-	1.4865	G-X40NiCrSi	330C11	-	XG50NiCr	
19	5390 A	2.4603	-	-	NC22FeD	-	
19	-	2.4630	NiCr20Ti	HR5, 203-4	NC20T	-	
19	5666	2.4856	NiCr22Mo9N	-	NC22FeDNB	-	
19	5537 C	LW2.496	CoCr20W15	-	KC20WN	-	
19	4676	2.4375	NiCu30Al	3072-76	-	-	
19	-	2.4631	NiCr20TiAk	Hr40,601	NC20TA	-	
19	AMS 5399	2.4973	NiCr19Co11	-	NC19KDT	-	
21	5391	LW2.467	S-NiCr13A16	3146-3	NC12AD	-	
21	5660	LW2.466	NiCr19Fe19	HR8	NC19FeNb	-	
21	5383	LW2.466	NiCr19Fe19	-	NC20K14	-	
21	-	-	CoCr22W14	-	KC22WN	-	
21	-	LW2.467	NiCo15Cr10	-	-	-	
23	-	-	TiAl14Mo4Sn4Si0.5	-	-	-	
23	-	-	TiAl5Sn2.5	TA14/17	T-A5E	-	
23	-	-	TiAl6V4	TA10-13/TA2	T-A6V	-	
23	-	-	TiAl6V4ELI	TA11	-	-	

Thread Turning
Technical Data

Sweden SS	Japan JIS	Russia GOST	Spain UNE	Vardex No.	
2301	SUS403	08Ch13	F.3110-X6Cr13 ; F.8401-AM-X12Cr13	12	M
-	-	08Ch13	F.3110-X6Cr13 ; F.8401-AM-X12Cr13	12	
2302	SUS410	12Ch13 ; 15Ch13L	F.3401-X10Cr13	12	
2320	SUS430	12Ch17	F.3113-X6Cr17	12	
-	SCS2	20Ch13L	-	12	
2304	SUS420J2	40Ch13	F.3405-X45Cr13	12	
2321	SUS431	20Ch17N2	F.3427-X19CrNi172	12	
2383	SUS430F	-	F.3117-X10CrSi17 ; F.3413-X14CrMoS17	12	
2325	SUS434	-	F.3116-X6CrMo171	12	
-	SCS5	-	-	12	
-	SCS14	07Ch18N10G2S2M2L	F.8414-AM-X7CrNiMo2010	12	
-	SUH1	40Ch9S2	F.3220-X45CrSi09-03	12	
-	SUS405	10Ch13SJu	F.3152-X10CrAl13	12	
-	SUH21	15Ch18SJu	F.3153-X10CrAl18	11	
-	SUH4	-	F.3222-X80CrSiNi20-02	12	
2322	SUH446	-	F.3154-X10CrAl24	11	
2332	SUS304	08Ch18N10	F.3551-X5CrNi1811; F.3541-X5CrNi1810 ; F.3504-X6CrNi1910	13	
2346	SUS303	-	F.3508-X10CrNiSi18-09	13	
2352	SCS19; SUS304L	03Ch18N11	F.3503-X2CrNi1810	13	
2333	SCS13	07Ch18N9L	-	13	
2331	SUS301	-	F.3517-X12CrNi177	13	
2371	SUS304LN	-	F.3541-X2CrNi1810	13	
2347	SUS316	-	F.3534-X5CrNiMo17122	13	
2375	SUS316LN	-	F.3543-X2CrNiMoN17133	13	
2353	SCS16	03Ch17N14M3	F.3533-X2CrNiMo17132	13	
2367	SUS317L	-	F.3539-X2CrNiMo18164	13	
2324	SUS329L;	-	F.3309-X8CrNiMo27-05; F.3552-X8CrNiMo266	13	
58B	SUS321	06Ch18N10T; 08Ch18N10T; 09Ch18N10T; 12Ch18N10T	F.3523-X6CrNiTi1810	12	
2338	SUS347	08Ch18N12B	F.3524-X6CrNiNb1810	12	
2350	-	10Ch17N13M2T	F.3535-X6CrNiMoTi17122	12	
-	SCS22	-	-	12	
-	-	-	-	12	
-	SUH309	20Ch20N14S2	F.3312-X15CrNiSi20-12	13	
2361	SUH310	20Ch23N18	-	13	
-	SUH330	-	F.3313-X12CrNiSi36-16	13	
-	SCH15	-	-	13	
-	SUH35;SUH36;SU321	55Ch20G9AN4	F.3217-X53CrMnNiN21-09	13	
-	-	-	-	13	
01 10	-	C410	FG10	30	K
01 15	-	C415	FG15	30	
01 20	-	C420	FG20	30	
01 25	-	C425	FG25	29	
01 30	-	C430	FG30	29	
01 35	-	C435	FG35	29	
01 40	-	C440	-	29	
MB	-	-	-	29	
ISO-215	-	-	-	29	
523	-	-	-	29	
07 17-02	-	VC42-12	-	30	
07 17-12	-	VC42-12	-	30	
07 17-15	-	-	-	30	
07 27-02	-	VC50-2	-	31	
07 32-03	-	VC60-2	-	31	
07 37-01	-	VC70-2	-	31	
07 72	-	-	-	31	
07 76	-	-	-	31	
-	-	-	-	31	
08 15	-	-	-	28	
08 52	-	-	-	29	
08 54	-	-	-	29	
08 58	-	-	-	29	
08 62	-	-	-	29	
4260	-	-	-	36	
4247	-	-	-	36	
4250	-	-	-	36	
4253	-	-	-	36	
4261	-	-	-	36	
-	SUH 330	-	F.3313-X12CrNiSi36-16	19	S
-	SCH 15	-	-	19	
-	-	-	-	19	
-	-	-	-	19	
-	-	-	-	19	
-	-	-	-	19	
-	-	-	-	19	
-	-	-	-	19	
-	-	-	-	19	
-	-	-	-	19	
-	-	-	-	19	
-	-	-	-	21	
-	-	-	-	21	
-	-	-	-	21	
-	-	-	-	21	
-	-	-	-	23	
-	-	-	-	23	
-	-	-	-	23	
-	-	-	-	23	

Troubleshooting

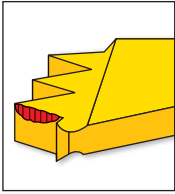
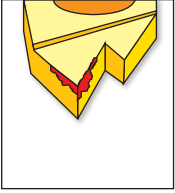
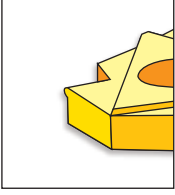
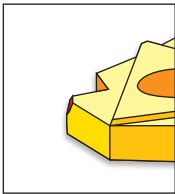
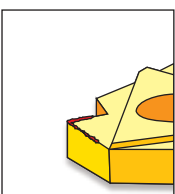
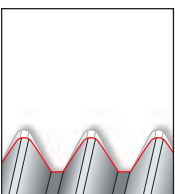
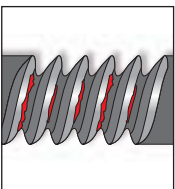
Problem	Possible Cause	Solution
 <p>Increased flank wear</p>	Cutting speed too high -----> Depth of cut too low/ too many passes -----> Unsuitable carbide grade -----> Insufficient cooling ----->	Reduce cutting speed / use coated insert Increase the depth of cut per pass Use a coated carbide grade Increase coolant flow rate
 <p>Uneven cutting edge wear</p>	Incorrect helix angle -----> Wrong infeed method ----->	Choose the correct anvil Use the alternating flank infeed method
 <p>Extreme plastic deformation</p>	Depth of cut too large -----> Insufficient cooling -----> Cutting speed too high -----> Unsuitable carbide grade -----> Nose radius too small ----->	Decrease depth of cut/ increase number of passes Increase coolant flow rate Reduce cutting speed Use a tougher carbide Use an insert with a larger radius, if possible
 <p>Cutting edge breakage</p>	Depth of cut too large -----> Extreme plastic deformation -----> Insufficient cooling -----> Unsuitable carbide grade -----> Instability ----->	Decrease depth of cut/ increase number of passes Use a tougher carbide Increase flow rate and/ or correct flow direction Use a tougher carbide Check stability of the system
 <p>Built-up edge</p>	Incorrect cutting speed -----> Unsuitable carbide grade ----->	Change the cutting speed Use a coated carbide
 <p>Thread profile is too shallow</p>	The tool is not at the workpiece axis height ----> Insert is not machining the thread crest -----> Worn insert ----->	Change tool height Measure the workpiece diameter Change the cutting edge sooner
 <p>Poor surface quality</p>	Cutting speed too low -----> Wrong anvil -----> Flank infeed method is not appropriat ----->	Increase cutting speed Choose correct anvil Use the alternate flank or radial infeed method

VRX

Multipurpose Premium Grade

Multipurpose Thread Turning Grade for Stronger
Wear Resistance and Improved Productivity

Redefining the **Threading** Benchmark

Thread Turning
Technical Data



AlTiN Alloyed PVD Coating

High Oxidation Temperature

Submicron Substrate



See page 204 for more information.

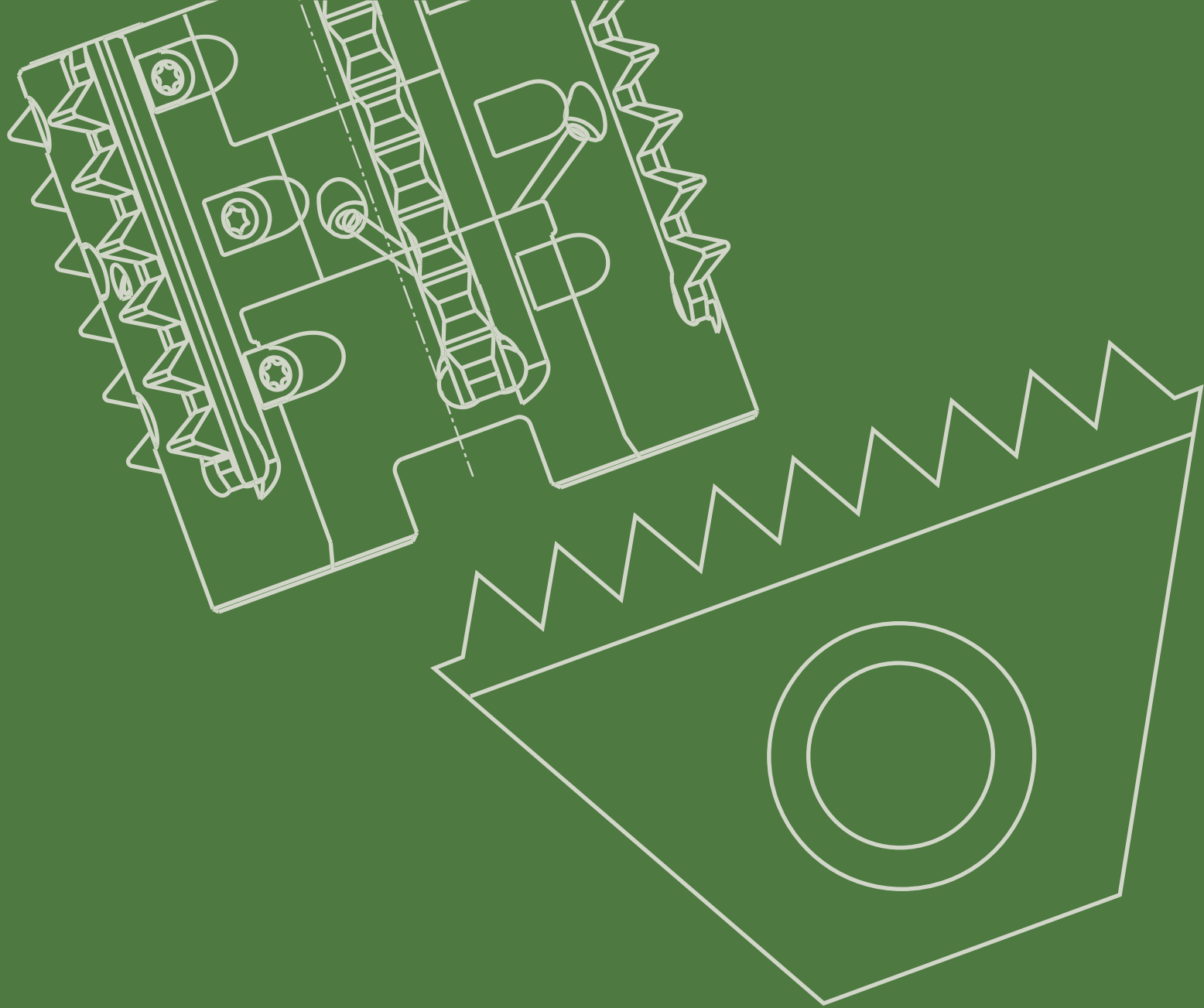

THREAD MILLING

■ MiTM	231
■ TM Standard	253
■ TMSD	295
■ TM Solid	331
■ Technical Data	369

Thread Milling Systems

MiTM Multi-Flute Indexable Thread Mill Inserts

MiTM19 (A) For Small Bores



Standard



Conical

MiTM24 (M) For Medium Bores



Standard



Conical

MiTM25 (S) For Standard Applications



Standard



Conical



Shell Mill



Shell Mill Conical

MiTM40 (L) For Long Threads



Standard



Shell Mill



Shell Mill Conical

MiTM41 (B) For Large Pitches



Standard



Shell Mill

Standard

Standard / TMF



Mini TMMC



Standard TMC



Coarse 124/...



TMLC



TM2C



TMOC



TM Shell Mill

Coarse Pitch



Coarse 124/...
(Standard TMC Style)



Coarse 124/...
(Mini TMMC Style)

Conical



TMNC

TMSC - Single Point



TMSC

TMVC - Single Point Vertical



TMVC

Thread Milling Systems

TMSD Thread Milling for Deep Holes

U Style For Large Pitches



L Style (Mini L) For Small Bores and Short L2



Vertical Style (7V, 9V, 11V)



L Style (3/8" L) For Large Trapezoid Profiles and ABUT



A Style For Shorter L2



TM Solid Solid Carbide Thread Milling Tools

Helical Flutes with Coolant



Helical Flutes



Miniature Tools



Straight Flutes



Long Tools



Thread Milling Methods

(for RH Tools only)

External

Right Hand Thread - Conventional Milling

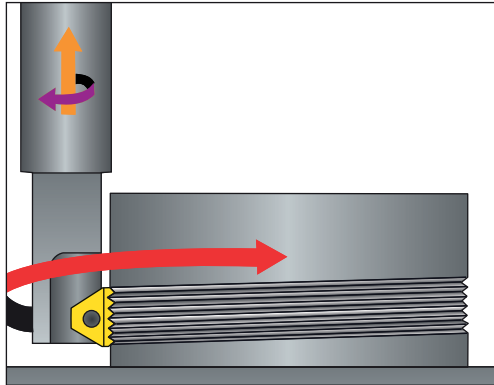

Left Hand Thread - Conventional Milling

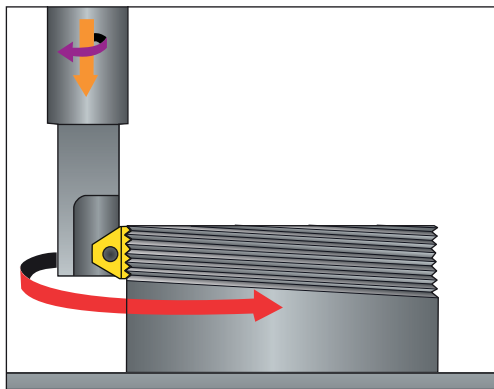

Right Hand Thread - Climb Milling

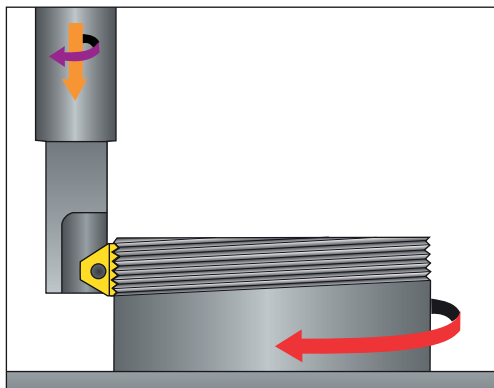

Left Hand Thread - Climb Milling

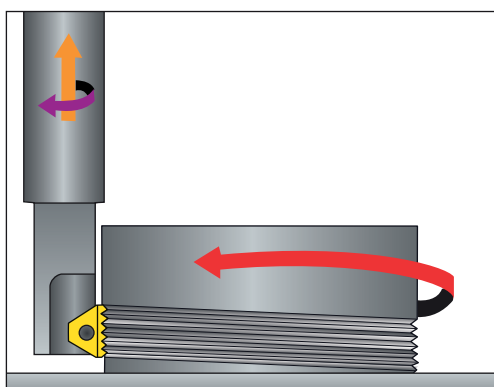

Internal

Right Hand Thread - Conventional Milling

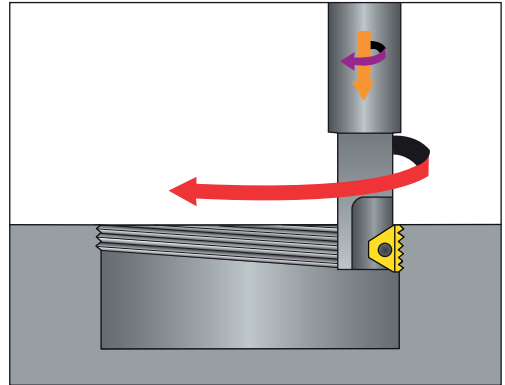

Left Hand Thread - Conventional Milling

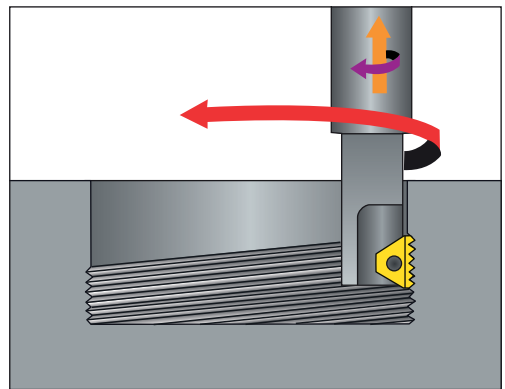

Right Hand Thread - Climb Milling

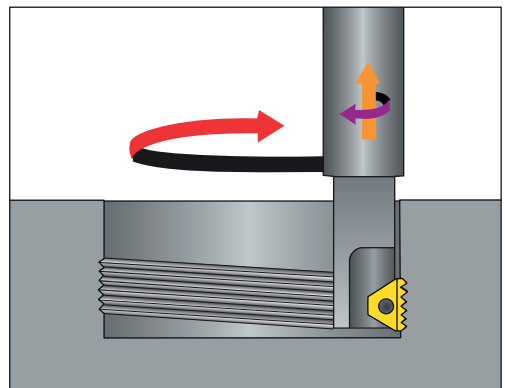

Left Hand Thread - Climb Milling

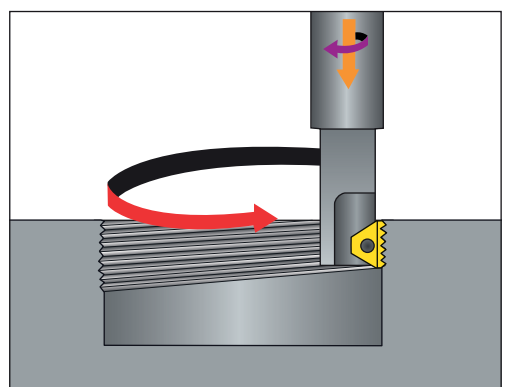

The Thread Milling Advantages

- Enables machining of large work pieces which cannot be easily mounted on a lathe
- Easily machine non-rotatable and asymmetrical parts
- Complete operation in one clamping
- Threading of large diameters requires less power than threading using taps
- No upper limits to bore diameter
- Chips are short
- Blind holes without a thread relief groove can be machined
- Thread relief grooves are unnecessary
- One holder can be used for both internal and external threads
- One tool can be used for both right hand and left hand thread
- Inventory can be reduced to a minimum as small range of tooling covers a wide range of thread diameters
- Interchangeable inserts
- Suitable for machining of hard materials
- Threads have a high surface finish
- Allows for correction of tool diameter and length
- Interrupted cuts are easily machined
- One tool for a wide range of materials
- A better thread quality in soft materials where taps normally tear the material
- Short machining time due to high cutting speed and rapid feed rates
- Small cutting forces allow machining of parts with thin walls





MiTM

Super Fast Thread Milling System

Inserts | Toolholders

Vardex Ordering Code System

MiTM Inserts

R	25	I	1.00	ISO	TM	VBX
1	2	3	4	5	6	7
1 - Product Line	2 - Insert Style	3 - Type of Insert	4 - Pitch	5 - Standard	6 - System	7 - Carbide Grade
R- MiTM line	19, 24, 25, 40, 41	I - Internal E - External EI-External+Internal NC- Plug	0.5-6.0 mm 32-4 tpi	ISO- ISO Metric UN-American UN W- BSW, BSP NPT-NPT NPTF-NPTF BSPT-BSPT	TM	VBX VTX

MiTM Holders

R	TM	C	25	17	-	26	S	2
1	2	3	4	5		6	7	8
1 - Product Line	2 - Holder Type	3 - Cooling	4 - Shank Dia. [mm]	5 - Cutting Dia. [mm]				
R - MiTM line BR - MiTM with Anti-vibration System	TM - Standard Holder TMN - Conical Holder	C- Coolant Channel	12, 20, 25, 32	10 - 36				
6 - Tool Overhang [mm]	7 - Insert Style	8 - No. of Flutes						
19 - 80	A - 19 M - 24 S - 25 L - 40 B - 41	1 - 5						

MiTM Shell Mill

R	TM	C	-	D36	-	16	-	25S	5
1	2	3		4		5		6	7
1 - Product Line	2 - Holder Type	3 - Cooling	4 - Cutting Dia. [mm]		5 - Drive Hole Dia. [mm]				
R - MiTM line	TM - Standard Holder TMN - Conical Holder	C- Coolant Channel	36 - 58		16, 22, 27				
6 - Insert Style	7 - No. of Flutes								
25S 40L 41B	5 - 8								

MiTM

The VARDEX Multi-flute Indexable Thread Milling (MiTM) system for fast machining, reduces cycle times when machining threads with long inserts. Nickel coating for all MiTM toolholders provides better anti-rust protection.



MiTM

MiTM 19 (A) For Small Bores



Standard
No. of Flutes (Z) 1
Cutting Dia. (D2) 10.0-11.75
Tool Overhang (L1) 20.0-25.2



Conical
No. of Flutes (Z) 1
Cutting Dia. (D2) 10.2
Tool Overhang (L1) 19.0

MiTM 24 (M) For Medium Bores



Standard
No. of Flutes (Z) 1-2
Cutting Dia. (D2) 13.6-16
Tool Overhang (L1) 26-36



Conical
No. of Flutes (Z) 1
Cutting Dia. (D2) 13.9
Tool Overhang (L1) 26

MiTM 25 (S) For Standard Applications



Standard
No. of Flutes (Z) 2-5
Cutting Dia. (D2) 17-30
Tool Overhang (L1) 26-80



Conical
No. of Flutes (Z) 2-4
Cutting Dia. (D2) 17-28
Tool Overhang (L1) 26-43



Shell Mill
No. of Flutes (Z) 5-8
Cutting Dia. (D2) 36-52
Tool Overhang (L1) max.200



Shell Mill Conical
No. of Flutes (Z) 5
Cutting Dia. (D2) 36
Tool Overhang (L1) max.200

MiTM 40 (L) For Long Threads



Standard
No. of Flutes (Z) 3-4
Cutting Dia. (D2) 22-30
Tool Overhang (L1) 43-80



Shell Mill
No. of Flutes (Z) 6-8
Cutting Dia. (D2) 44-52
Tool Overhang (L1) max.200



Shell Mill Conical
No. of Flutes (Z) 6
Cutting Dia. (D2) 45
Tool Overhang (L1) max.200

MiTM 41 (B) For Large Pitches



Standard
No. of Flutes (Z) 1-5
Cutting Dia. (D2) 24.5-36
Tool Overhang (L1) 43-65



Shell Mill
No. of Flutes (Z) 5-6
Cutting Dia. (D2) 48-58
Tool Overhang (L1) max.200

ISO Metric

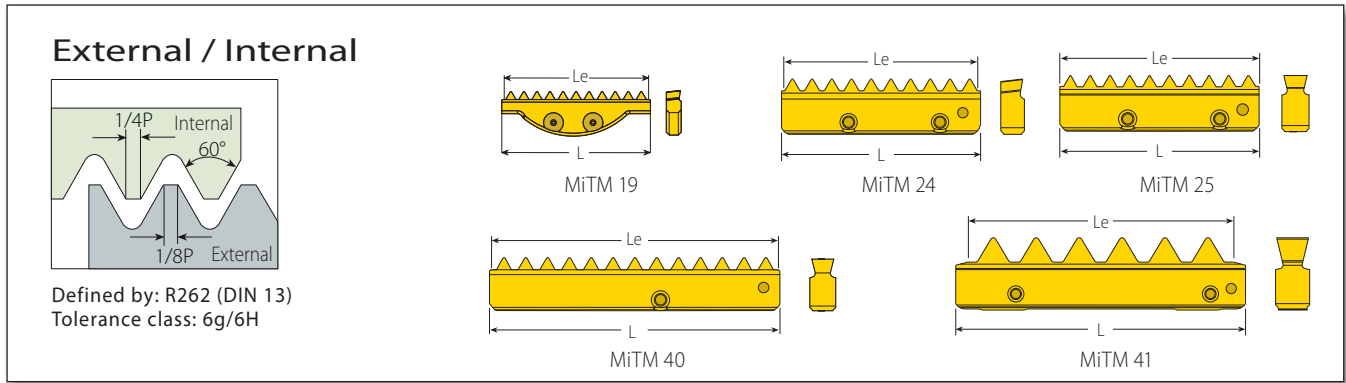

Standard MiTM

	L mm	Pitch mm	Ordering Code		Cutting Edge Le	Teeth Zt	Toolholder
			External	Internal			
	19	0.5		R19I0.50ISOTM...	1	20.0	RTMC...A
		0.75		R19I0.75ISOTM...	1	20.0	
		1.0		R19I1.00ISOTM...	1	20.0	
		1.25		R19I1.25ISOTM...	1	20.0	
		1.5		R19I1.50ISOTM...	1	19.5	
		1.75		R19I1.75ISOTM...	1	19.25	
		2.0		R19I2.00ISOTM...	1	20.0	
	24	0.5		R24I0.50ISOTM...	1	24.5	RTMC...M
		0.75		R24I0.75ISOTM...	1	24.75	
		1.0		R24I1.00ISOTM...	1	24.0	
		1.25		R24I1.25ISOTM...	1	25.0	
		1.5		R24I1.50ISOTM...	1	24.0	
		1.75		R24I1.75ISOTM...	1	24.5	
		2.0		R24I2.00ISOTM...	1	24.0	
	25	1.0	R25E1.00ISOTM...	R25I1.00ISOTM...	2	24.0	(B)RTMC...S
		1.25	R25E1.25ISOTM...	R25I1.25ISOTM...	2	23.75	
		1.5	R25E1.50ISOTM...	R25I1.50ISOTM...	2	24.0	
		2.0	R25E2.00ISOTM...	R25I2.00ISOTM...	2	24.0	
		2.5	R25E2.50ISOTM...	R25I2.50ISOTM...	2	25.0	
		3.0	*R25E3.00ISOTM...	*R25I3.00ISOTM...	2	24.0	
	40	1.0		R40I1.00ISOTM...	2	39.0	(B)RTMC...L
		1.5		R40I1.50ISOTM...	2	39.0	
		2.0		R40I2.00ISOTM...	2	38.0	
		2.5		R40I2.50ISOTM...	2	37.5	
		3.0		R40I3.00ISOTM...	2	39.0	
	41	3.0	R41E3.00ISOTM...	R41I3.00ISOTM...	2	39.0	RTMC...B
		3.5	R41E3.50ISOTM...	R41I3.50ISOTM...	2	38.5	
		4.0	R41E4.00ISOTM...	R41I4.00ISOTM...	2	40.0	
		4.5	R41E4.50ISOTM...	R41I4.50ISOTM...	2	40.5	
		5.0	R41E5.00ISOTM...	R41I5.00ISOTM...	2	40.0	
		5.5	R41E5.50ISOTM...	R41I5.50ISOTM...	2	38.5	
		6.0	R41E6.00ISOTM...	R41I6.00ISOTM...	2	36.0	

* 3.0 ISO inserts do not fit into toolholder RTMC2517...
For external insert 3.0 ISO use for CNC program (D2 + 0.5mm).

MiTM inserts 25, 40 and 41 are offered with 2 cutting edges. In case of chip flow difficulty, inserts with a single cutting edge can be ordered by request. Example: R25I2.00ISOTM(S)...

American UN - UNC, UNF, UNEF, UNS

External / Internal

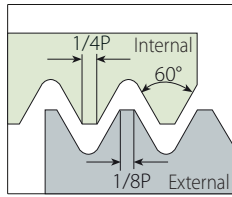

Defined by: ANSI B1.1:74
Tolerance class: 2A/2B

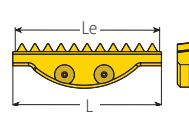

MiTM 19

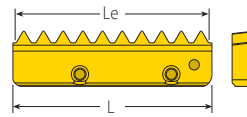

MiTM 24

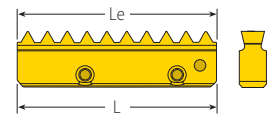

MiTM 25

Standard MiTM



	L mm	Pitch tpi	Ordering Code		Cutting Edge Le	Teeth Zt	Toolholder
			External	Internal			
19	32			R19I32UNTM...	1	19.84	RTMC...A
	28			R19I28UNTM...	1	19.96	
	27			R19I27UNTM...	1	19.76	
	24			R19I24UNTM...	1	20.11	
	20			R19I20UNTM...	1	19.05	
	18			R19I18UNTM...	1	19.76	
	16			R19I16UNTM...	1	19.05	
	14			R19I14UNTM...	1	19.96	
	13			R19I13UNTM...	1	19.54	
24	32			R24I32UNTM...	1	24.61	RTMC...M
	28			R24I28UNTM...	1	24.49	
	24			R24I24UNTM...	1	24.34	
	20			R24I20UNTM...	1	24.13	
	18			R24I18UNTM...	1	23.99	
	16			R24I16UNTM...	1	23.81	
	14			R24I14UNTM...	1	23.59	
	12			R24I12UNTM...	1	23.28	
	10			R24I10UNTM...	1	22.86	
25	20		R25E20UNTM...	R25I20UNTM...	2	24.13	(B)RTMC...S
	18		R25E18UNTM...	R25I18UNTM...	2	23.99	
	16		R25E16UNTM...	R25I16UNTM...	2	23.81	
	14		R25E14UNTM...	R25I14UNTM...	2	23.58	
	12		R25E12UNTM...	R25I12UNTM...	2	23.28	
	10		R25E10UNTM...	R25I10UNTM...	2	22.86	
	9		*R25E9UNTM...	*R25I9UNTM...	2	22.58	
	8		*R25E8UNTM...	*R25I8UNTM...	2	22.22	

* 8 UN & 9 UN inserts do not fit into toolholder RTMC2517...
For external insert 8 UN use for CNC program (D2 + 0.5mm).

MiTM inserts 25, 40 and 41 are offered with 2 cutting edges. In case of chip flow difficulty, inserts with a single cutting edge can be ordered by request. Example: R25I20UNTM(S)...



American UN - UNC, UNF, UNEF, UNS (con't)

External / Internal

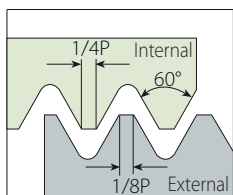

Defined by: ANSI B1.1:74
Tolerance class: 2A/2B

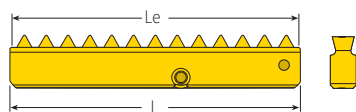

MiTM 40

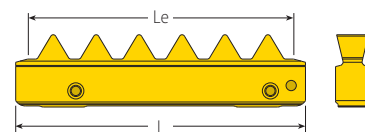

MiTM 41

MiTM

Standard MiTM

	L	Pitch	Ordering Code		Cutting Edge	Teeth	Toolholder
			External	Internal			
40	mm	tpi			Le	Zt	
		20		R40I20UNTM...	2	39.37	31
		18		R40I18UNTM...	2	39.51	28
		16		R40I16UNTM...	2	39.69	25
		14		R40I14UNTM...	2	39.91	22
		12		R40I12UNTM...	2	38.10	18
		10		R40I10UNTM...	2	38.10	15
		9		R40I9UNTM...	2	39.51	14
41		8	R41E8UNTM...	R41I8UNTM...	2	38.10	12
		7	R41E7UNTM...	R41I7UNTM...	2	39.91	11
		6	R41E6UNTM...	R41I6UNTM...	2	38.10	9
		5	R41E5UNTM...	R41I5UNTM...	2	35.56	7
		4.5	R41E4.5UNTM...	R41I4.5UNTM...	2	39.51	7
		4	R41E4UNTM...	R41I4UNTM...	2	38.10	6

(B)RTMC...L

RTMC...B

MiTM inserts 25, 40 and 41 are offered with 2 cutting edges. In case of chip flow difficulty, inserts with a single cutting edge can be ordered by request. Example: R25I20UNTM(S)...



Whitworth for BSF, BSP (G)

External / Internal

Defined by: B.S.84:1956, DIN 259,
DIN ISO228/1:1982
Tolerance class: Medium Class A

Standard MiTM

	L	Pitch	Ordering Code		Cutting Edge	Teeth	Toolholder	
	mm	tpi	External+ Internal	Internal	Le	Zt		
	19	19	R19EI19WTM...		1	20.05	15	
		16	R19EI16WTM...		1	19.05	12	RTMC...A
		14	R19EI14WTM...		1	19.96	11	
	24	19	R24EI19WTM...		1	24.06	18	
		14	R24EI14WTM...		1	23.59	13	RTMC...M
		12	R24EI12WTM...		1	23.28	11	
	25	16	R25EI16WTM...		2	23.81	15	
		14	R25EI14WTM...		2	23.58	13	(B)RTMC...S
		12	R25EI12WTM...		2	23.28	11	
		11	R25EI11WTM...		2	23.09	10	
	40	16	R40EI16WTM...		2	39.69	25	
		14	R40EI14WTM...		2	39.91	22	(B)RTMC...L
		12	R40EI12WTM...		2	38.10	18	
		11	R40EI11WTM...		2	39.25	17	
	41	8		R41I8WTM...	2	38.10	12	
		7		R41I7WTM...	2	39.91	11	RTMC...B
		6		R41I6WTM...	2	38.10	9	

MiTM

MiTM inserts 25, 40 and 41 are offered with 2 cutting edges. In case of chip flow difficulty, inserts with a single cutting edge can be ordered by request. Example: R25EI16WTM(S)...

NPT

External / Internal

Defined by: USAS B2.1:1968
Tolerance class: Standard NPT

MiTM

Standard MiTM



L	Pitch	Ordering Code	Cutting Edge	Teeth	Toolholder
mm	tpi	External+ Internal	Le	Zt	
19	18	R19EI18NPT-TM...	1	19.76	RTMNC....A
24	18	R24EI18NPT-TM...	1	23.99	RTMNC....M
25	14	R25EI14NPT-TM...	1	23.58	RTMNC....S
	11.5	R25EI11.5NPT-TM...	1	24.30	
40	8	R25EI8NPT-TM...	1	22.22	RTMNC-D36-16-25S5
	11.5	R40EI11.5NPT-TM...	1	37.55	RTMNC-D45-22-40L6
	8	R40EI8NPT-TM...	1	38.10	
41	8	R41EI8NPT-TM...	1	38.10	RTMC....B

NPTF

External / Internal

Defined by: ANSI B1.20.3-1976
Tolerance class: Standard NPTF

Standard MiTM



L	Pitch	Ordering Code	Cutting Edge	Teeth	Toolholder
mm	tpi	External+ Internal	Le	Zt	
19	18	R19EI18NPTFTM...	1	19.76	RTMNC....A
24	18	R24EI18NPTFTM...	1	23.99	RTMNC....M
25	14	R25EI14NPTFTM...	1	23.58	RTMNC....S
	11.5	R25EI11.5NPTFTM...	1	24.30	
40	8	R25EI8NPTFTM...	1	22.22	RTMNC-D36-16-25S5
	11.5	R40EI11.5NPTFTM...	1	37.55	RTMNC-D45-22-40L6
	8	R40EI8NPTFTM...	1	38.10	
41	8	R41EI8NPTFTM...	1	38.10	RTMC....B

BSPT

External / Internal

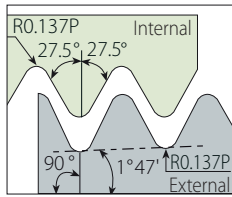

Defined by: B.S. 21:1985
Tolerance class: Standard BSPT

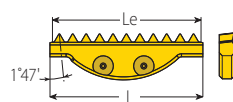

MiTM 19

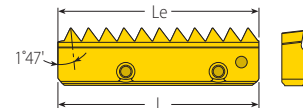

MiTM 24

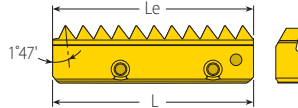

MiTM 25

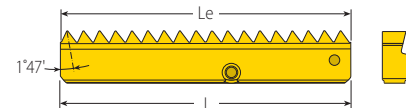

MiTM 40

Standard MiTM



L	Pitch	Ordering Code	Cutting Edge	Teeth	Toolholder	
mm	tpi	External+ Internal	Le	Zt		
19	19	R19EI19BSPT-TM...	1	20.05	15	RTMNC...A
24	19	R24EI19BSPT-TM...	1	24.06	18	RTMNC 2014-26M1
25	14	R25EI14BSPT-TM...	1	23.58	13	RTMNC...S
	11	R25EI11BSPT-TM...	1	23.09	10	
40	11	R40EI11BSPT-TM...	1	39.25	17	RTMNC-D45-22-40L6

Plug Insert



L	Ordering Code	Teeth	Toolholder	
mm	External+ Internal	Zt		
24	R24NC	No Teeth	RTMC...M	
25	R25NC		(B)RTMC...S	All Types
			RTMNC...S	
40	R40NC		(B)RTMC...L	
41	R41NC	RTMNC...L		
			RTMC...B	

Fill unused toolholder pockets with plug inserts (R...NC).
This assures balance and prevents instability and chips from packing into empty pockets.

MiTM

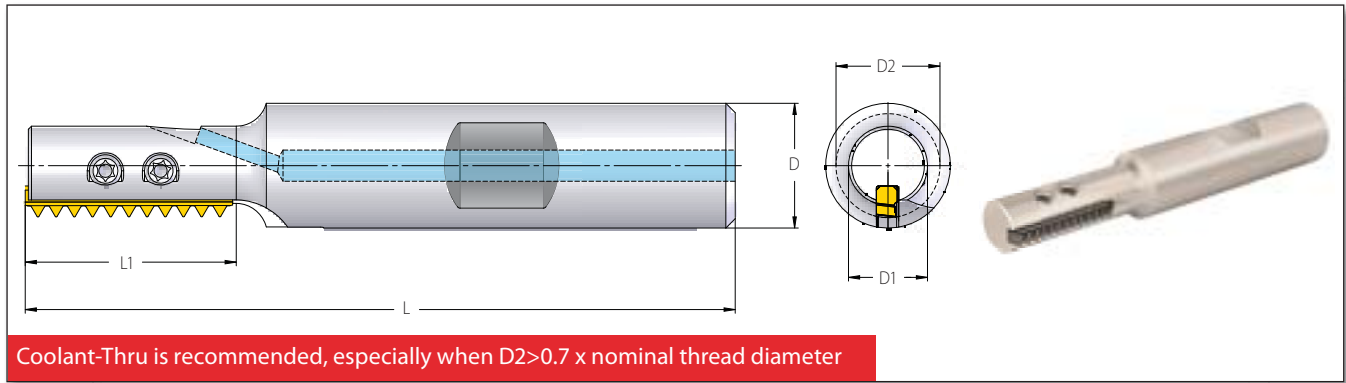

Standard Toolholders (MiTM 19)



MiTM

RTMC - for Standard Threads

Spare Parts

Insert Style	Ordering Code	Dimensions mm						No. of Flutes		
mm		L	L1	D	D1	D2	Z	Location Screw x2	Torx+ Screwdriver	
19	RTMC1210-20A1	68	20	12	7.5	10	1	SLD3IP6 (M3x0.5)	KIP6 Use the included Vardex Torx+ screwdriver only. Recommended max. torque 1.2 NxM	
	RTMC1212-25A1	73.5	25.2	12	8.7	11.75	1			

Standard Thread Application by Toolholder

Toolholder	Min. Thread Dia.							
	D2 (mm)	ISO (coarse)	ISO (fine)	UNC	UN/UNF/UNEF/UNS	BSF	BSP(G)	
RTMC1210-20A1	10	M12x1.75	M11x0.5; M11x0.75; M11.5x1; M12x1.25; M12x1.5	1/2-13	7/16-32UN; 7/16-28UNEF; 7/16-27UNS; 1/2-24UNS; 1/2-20UNF; 1/2-18UNS; 1/2-16UN; 1/2-14UNS	1/2-16	1/4-19	
RTMC1212-25A1	11.75	M14x2.0; M16x2.0	M12.5x0.5; M13x0.75; M13x1; M13.5x1.25; M14x1.5; M14x1.75	5/16-12	1/2-32UN; 9/16-28UNS; 9/16-27UNS; 9/16-24UNEF; 9/16-20UN; 9/16-18UNF; 9/16-16UN; 9/16-14UNS;	5/8-14	1/4-14	

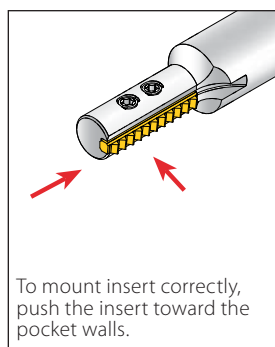
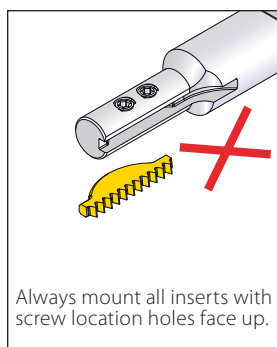
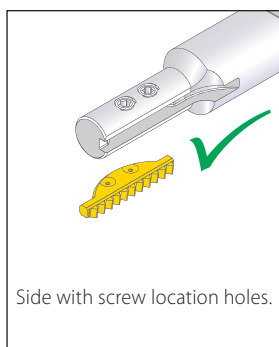

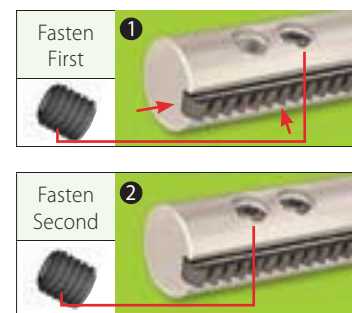

2 Step Clamping System

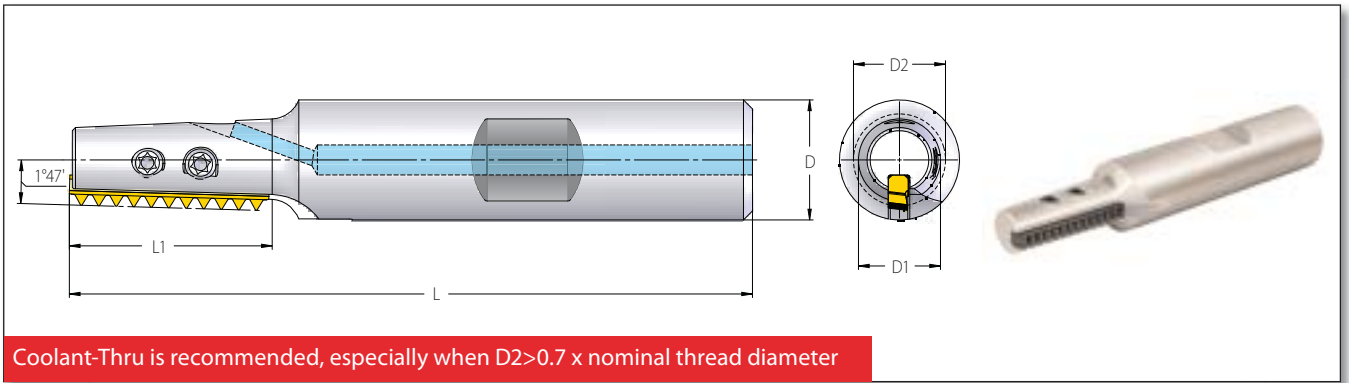

Conical Toolholders (MiTM 19)



RTMNC - for Conical Threads

RTMNC - for Conical Threads								Spare Parts	
Insert Style	Ordering Code	Dimensions mm					No. of Flutes		
mm		L	L1	D	D1	D2	Z	Location Screw x2	Torx+ Screwdriver
19	RTMNC1210-19A1	66.5	19	12	8	10.6	1	SLD3IP6 (M3x0.5)	KIP6 Use the included Vardex Torx+ screwdriver only. Recommended max. torque 1.2 NxM

Conical Thread Application by Toolholder

Toolholder	D2 (mm)			
	NPT	NPTF	BSPT	
RTMNC1210-19A1	1/4-18* 3/8-18	1/4-18* 3/8-18	1/4-19* 3/8-19	

* Using MiTM 19 tools the maximum thread length is 10.5mm.

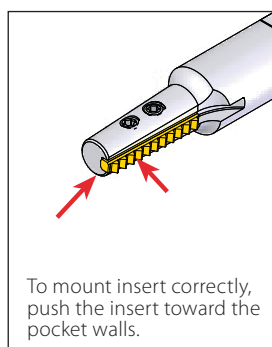
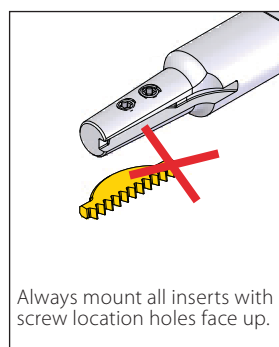
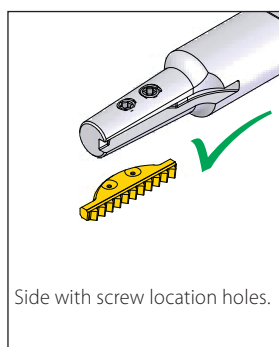

2 Step Clamping System

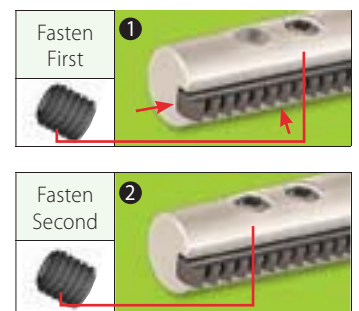

Standard Toolholders (MiTM 24)

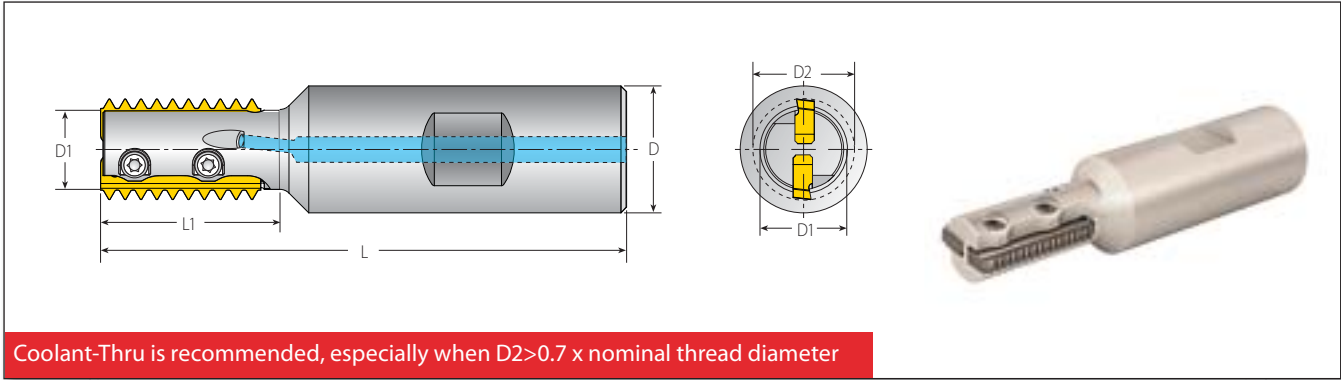

RTMC - for Standard Threads

Spare Parts

Insert Style	Ordering Code	Dimensions mm						No. of Flutes		
mm		L	L1	D	D1	D2	Z	Location Screw x2	Torx+ Screwdriver	
24	RTMC2013-26M1	82	26	20	10.7	13.6	1	SLD4IP8 (M4x0.7)	KIP8 Use the included Vardex Torx+ screwdriver only. Recommended max. torque 1.2 NxM	
	RTMC2015-30M1	85	30	20	11.9	15.1	1			
	RTMC2016-28M2	83	28	20	12.6	16	2			
	RTMC2016-36M1	91	36	20	12.6	16	1			

Standard Thread Application by Toolholder

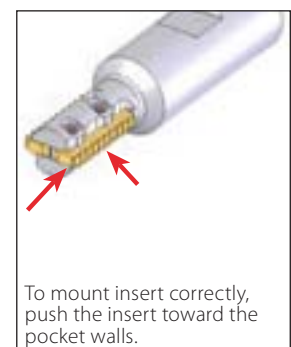

Toolholder	Min. Thread Dia.							
	D2 (mm)	ISO (coarse)	ISO (fine)	UNC	UN/UNF/UNEF/UNS	BSF	BSP(G)	
RTMC2013-26M1	13.6	M16x2	M14.5x0.5; M15x0.75; M15x1; M15x1.25; M16x1.5; M16x1.75	-	$\frac{1}{16}$ -12UN; $\frac{5}{8}$ -14UNS; $\frac{9}{8}$ -16UN; $\frac{9}{8}$ -18UNF; $\frac{9}{8}$ -20UN; $\frac{9}{8}$ -24UNEF; $\frac{9}{8}$ -28UN; $\frac{9}{8}$ -32UN	$\frac{1}{16}$ -14; $\frac{3}{4}$ -12	$\frac{3}{8}$ -19; $\frac{1}{2}$ -14	
RTMC2015-30M1	15.1	M18x2.5	M16x0.5; M17x0.75; M17x1; M17x1.25; M17x1.5; M18x1.75; M18x2	$\frac{3}{4}$ -10	$\frac{3}{4}$ -12UN; $\frac{3}{4}$ -14UNS; $\frac{1}{16}$ -16UN; $\frac{1}{16}$ -20UN; $\frac{1}{16}$ -24UNEF; $\frac{1}{16}$ -28UN; $\frac{1}{16}$ -32UN	$\frac{3}{4}$ -12	$\frac{1}{2}$ -14	
RTMC2016-28M2	16	M20x2.5	M17x0.5; M17x0.75; M18x1; M18x1.25; M18x1.5; M18x1.75; M19x2	$\frac{3}{4}$ -10	$\frac{3}{4}$ -12UN; $\frac{3}{4}$ -14UNS; $\frac{3}{4}$ -16UN; $\frac{3}{4}$ -18UNS; $\frac{3}{4}$ -20UNEF; $\frac{1}{16}$ -24UNEF; $\frac{1}{16}$ -28UN; $\frac{1}{16}$ -32UN	$\frac{3}{4}$ -12	$\frac{1}{2}$ -14	
RTMC2016-36M1	16	M20x2.5	M17x0.5; M17x0.75; M18x1; M18x1.25; M18x1.5; M18x1.75; M19x2	$\frac{3}{4}$ -10	$\frac{3}{4}$ -12UN; $\frac{3}{4}$ -14UNS; $\frac{3}{4}$ -16UN; $\frac{3}{4}$ -18UNS; $\frac{3}{4}$ -20UNEF; $\frac{1}{16}$ -24UNEF; $\frac{1}{16}$ -28UN; $\frac{1}{16}$ -32UN	$\frac{3}{4}$ -12	$\frac{1}{2}$ -14	

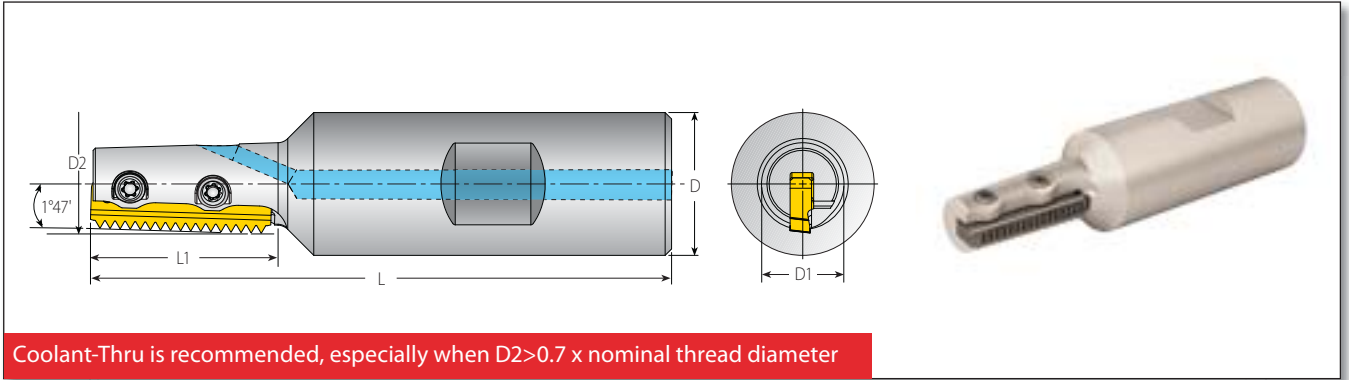

Conical Toolholders (MiTM 24)



RTMC - for Conical Threads

Insert Style	Ordering Code	Dimensions mm						No. of Flutes	Spare Parts	
		L	L1	D	D1	D2	Z		 Location Screw x2	 Torx+ Screwdriver
24	RTMNC2014-26M1	81	26	20	11.5	13.9	1	SLD4IP8 (M4x0.7)	KIP8 Use the included Vardex Torx+ screwdriver only. Recommended max. torque 1.2 NxM	

Conical Thread Application by Toolholder

Toolholder	D2 (mm)	Thread Dia.		
		NPT	NPTF	BSPT
RTMNC2014-26M1	13.9	3/8-18	3/8-18	3/8-19

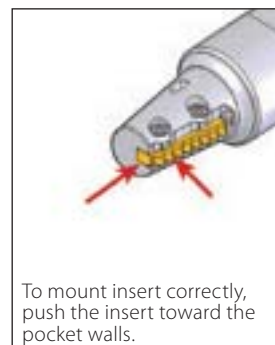
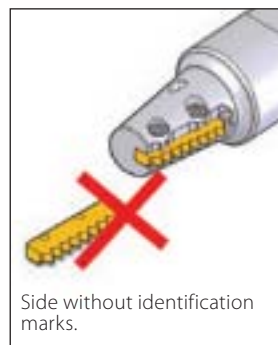

Standard Toolholders (MiTM 25)

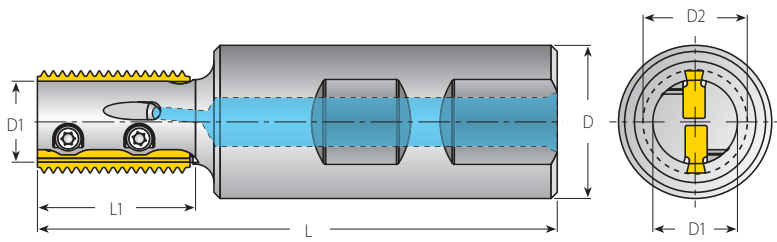

Coolant-Thru is recommended, especially when D2 > 0.7 x nominal thread diameter

RTMC - for Standard Threads

Spare Parts

Insert Style	Ordering Code	Dimensions mm						No. of Flutes	Location Screw x2	Torx+ Screwdriver
		mm	L	L1	D	D1	D2			
25	RTMC2517-26S2	85	26	25	25	14	17	2	SLD4IP8 (M4x0.7)	KIP8 Use the included Vardex Torx+ screwdriver only. Recommended max. torque 1.2 NxM
	RTMC2517-36S2	95	36			14	17	2		
	RTMC2519-32S2	92	32			15	19	2		
	RTMC2519-44S2	104	44			15	19	2		
	RTMC2520-37S3	96	37			16.5	20.5	3		
	RTMC2520-44S3	103	44			16.5	20.5	3		
	RTMC2522-43S3	102	43			18	22	3		
	RTMC2522-55S3	114	55			18	22	3		
	RTMC2530-55S5	115	55			26	30	5		
	BRTMC2530-80S4	140	80			26	30	4		

Standard Thread Application by Toolholder

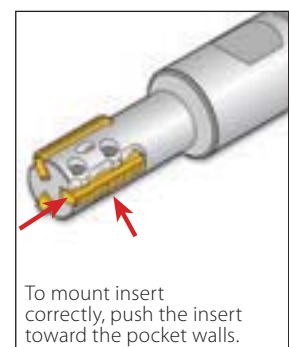
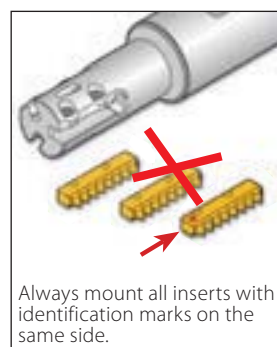
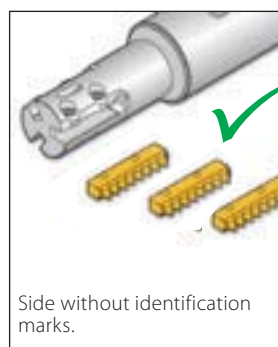
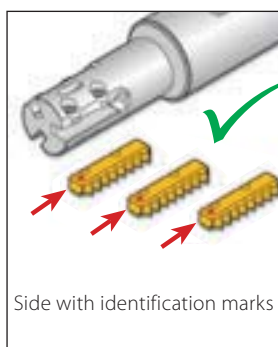

Toolholder	Min.Thread Dia.						
	D2 (mm)	ISO (coarse)	ISO (fine)	UNC	UN/UNF/UNEF/UNS	BSF	BSP(G)
RTMC2517-26S2 RTMC2517-36S2	17	M20x2.5	M19x1; M19x1.5; M20x2	-	7/8-10UNS; 13/16-12UN; 7/8-14UNF; 3/4-16UNF; 3/4-18UNS; 3/4-20UNEF	7/8-11; 7/8-12; 7/8-14; 7/8-16	1/2-14
RTMC2519-32S2 RTMC2519-44S2	19	M22x2.5 M24x3	M21x1; M21x1.5; M22x2	7/8-9; 1-8	7/8-20UNEF; 7/8-18UNS; 7/8-16UN; 7/8-14UNF; 7/8-12UN; 7/8-10UNS	7/8-16; 7/8-14; 15/16-12; 15/16-11	5/8-14
RTMC2520-37S3 RTMC2520-44S3	20.5	M24x3	M22x1; M23x1.5; M23x2; M23.5x2.5	1-8	15/16-9UN; 1-10UNS; 15/16-12UN; 1-14UNS; 15/16-16UN; 7/8-18UNS; 7/8-20UNEF	1-11; 1-12; 1-14; 1-16	5/8-14
RTMC2522-43S3 RTMC2522-55S3	22	M27x3	M24x1; M24x1.5; M25x2; M25x2.5	-	1 1/16-8UN; 1-9UN; 1-10UNS; 1-12UNF; 1-14UNS; 1-16UN; 1-18UN; 15/16-20UNEF	1-11; 1-12; 1-14; 1-16	3/4-14
RTMC2530-55S5 BRTMC2530-80S4	30	-	M32x1; M32x1.5; M33x2; M33x2.5; M34x3	-	1 3/8-8UN; 1 3/8-9UN; 1 3/8-10UN; 1 1/16-12UN; 1 1/8-14UNS; 1 1/16-16UN; 1 1/16-18UNEF; 1 1/16-20UN	1 3/8-11; 1 3/8-12; 1 3/8-14; 1 3/8-16	1-11

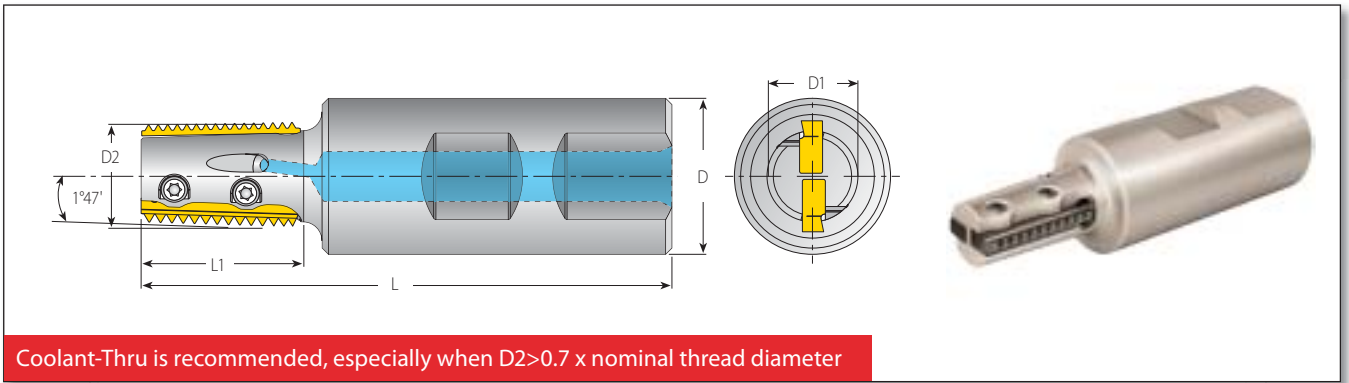

Conical Toolholders (MiTM 25)



RTMNC - for Conical Threads

Insert Style	Ordering Code	Dimensions mm						No. of Flutes	Spare Parts	
		L	L1	D	D1	D2	Z			
mm		L	L1	D	D1	D2	Z	Location Screw x2	Torx+ Screwdriver	
25	RTMNC2517-26S2	85	26	25	14	17.2	2	SLD4IP8 (M4x0.7)	KIP8 Use the included Vardex Torx+ screwdriver only. Recommended max. torque 1.2 NxM	
	RTMNC2522-43S3	102	43	25	18	22.2	3			
	RTMNC2528-43S4	103	43	25	25	28.4	4			

Conical Thread Application by Toolholder

Toolholder	D2(mm)	Thread Dia.		
		NPT	NPTF	BSPT
RTMNC2517-26S2	17.2	½-14; ¾-14; 1-11.5; 1¼-11.5; 1½-11.5; 2-11.5	½-14; ¾-14; 1-11.5; 1¼-11.5; 1½-11.5; 2-11.5	½-14; ¾-14
RTMNC2522-43S3	22.2	¾-14; 1-11.5; 1¼-11.5; 1½-11.5; 2-11.5	¾-14; 1-11.5; 1¼-11.5; 1½-11.5; 2-11.5	¾-14; 1-11; 1¼-11; 1½-11; 2-11; 2½-11; 3-11; 4-11; 5-11; 6-11
RTMNC2528-43S4	28.4	1-11.5; 1¼-11.5; 1½-11.5; 2-11.5	1-11.5; 1¼-11.5; 1½-11.5; 2-11.5	1-11; 1¼-11; 1½-11; 2-11; 2½-11; 3-11; 4-11; 5-11; 6-11

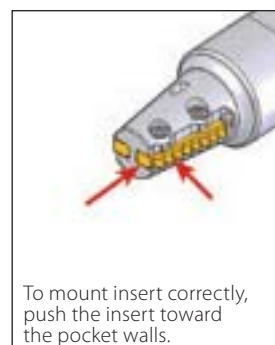
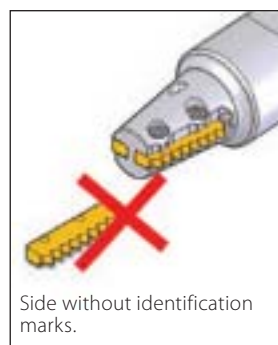
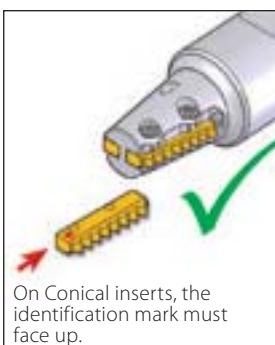

Shell Mill (MiTM 25)

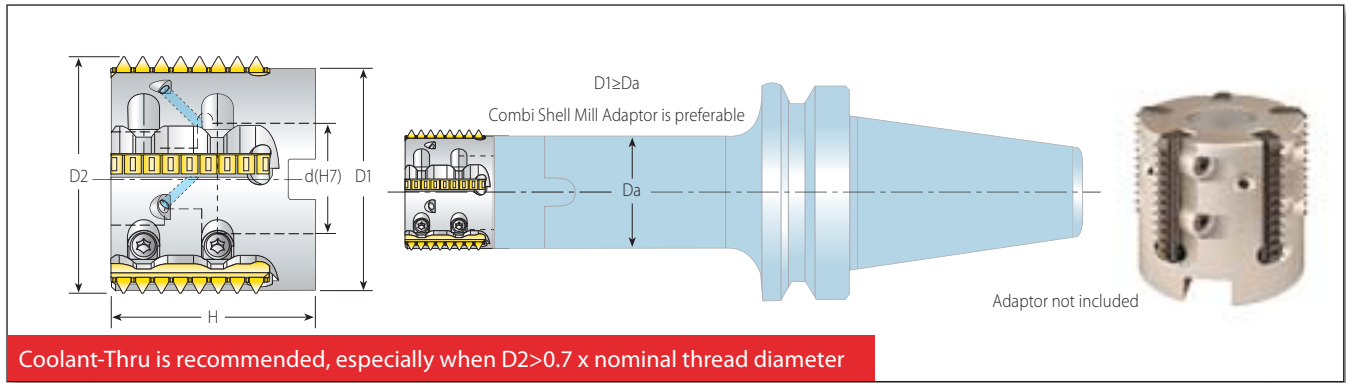

Conical and Standard Shell Mills

Spare Parts

Insert Style	Ordering Code	Dimensions mm			No. of Flutes					
mm		D1	D2	d(H7)	H	Z	Location Screw x2	Torx+ Screwdriver	Holder Screw	
Standard	25	RTMC-D36-16-25S5	32	36	16	33.5	5	SLD4IP8 (M4x0.7)	KIP8 Use the included Vardex Torx+ screwdriver only. Recommended max. torque 1.2 NxM	M8x1.25x35
		RTMC-D44-22-25S6	40	44	22	38.0	6			M10x1.50x35
		RTMC-D52-27-25S8	48	52	27	40.0	8			M12x1.75x30
Conical		RTMNC-D36-16-25S5	32	35.9*	16	33.5	5			M8x1.25x35

* For inserts 8NPT and 8NPTF use for CNC program 36.4mm.

Standard Thread Applications by Toolholder

Toolholder		Min. Thread Dia.				
		D2(mm)	ISO (fine)	UN/UNF/UNEF/UNS	BSW	BSP(G)
Standard	RTMC-D36-16-25S5	36	M38x1; M39x1.5; M39x2; M40x3	1 ¹ / ₁₆ -12UN; 1 ¹ / ₈ -14UNS; 1 ¹ / ₁₆ -16UN; 1 ¹ / ₂ -18UNEF; 1 ¹ / ₂ -20UN	1 ³ / ₄ -16 1 ³ / ₄ -12	1 ¹ / ₄ -11
	RTMC-D44-22-25S6	44	M48x1; M48x1.5; M48x2; M48x3	1 ⁷ / ₈ -12UN; 1 ¹ / ₂ -16UN; 1 ¹ / ₂ -20UN; 1 ¹ / ₁₆ -8UN; 1 ¹ / ₈ -10UNS; 1 ¹ / ₈ -14UNS	2-16 2-12	1 ¹ / ₂ -11
	RTMC-D52-27-25S8	52	M55x1; M55x1.5; M55x2; M56x3	2 ¹ / ₄ -8UN; 2 ¹ / ₄ -10UN; 2 ¹ / ₄ -12UN; 2 ¹ / ₄ -14UN; 2 ¹ / ₄ -16UN; 2 ¹ / ₄ -18UN; 2 ¹ / ₄ -20UN	2 ¹ / ₄ -16 2 ¹ / ₄ -12	2-11

Conical Thread Applications by Toolholder

Toolholder		Thread Dia.			
		D2 (mm)	NPT	NPTF	BSPT
Conical	RTMNC-D36-16-25S5	35.9*	1 ¹ / ₄ -11.5; 1 ¹ / ₂ -11.5; 2-11.5 2 ¹ / ₂ -8 (and up)	1 ¹ / ₄ -11.5; 1 ¹ / ₂ -11.5; 2-11.5 2 ¹ / ₂ -8; 3-8	1 ¹ / ₂ -6x11

* For inserts 8NPT and 8NPTF use for CNC program 36.4mm.

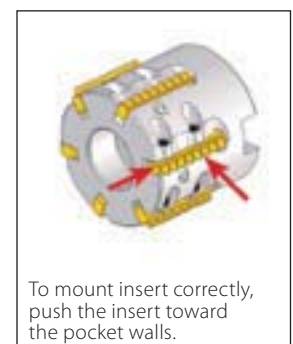
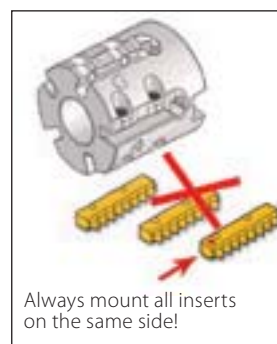
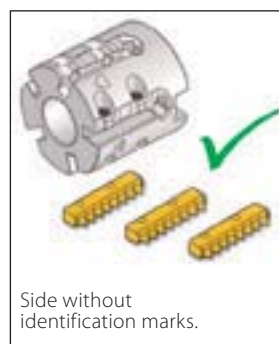
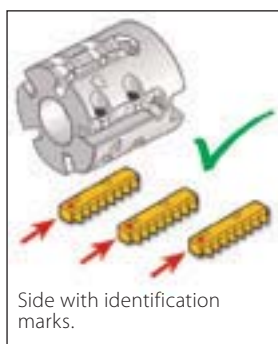

Standard Toolholders (MiTM 40)

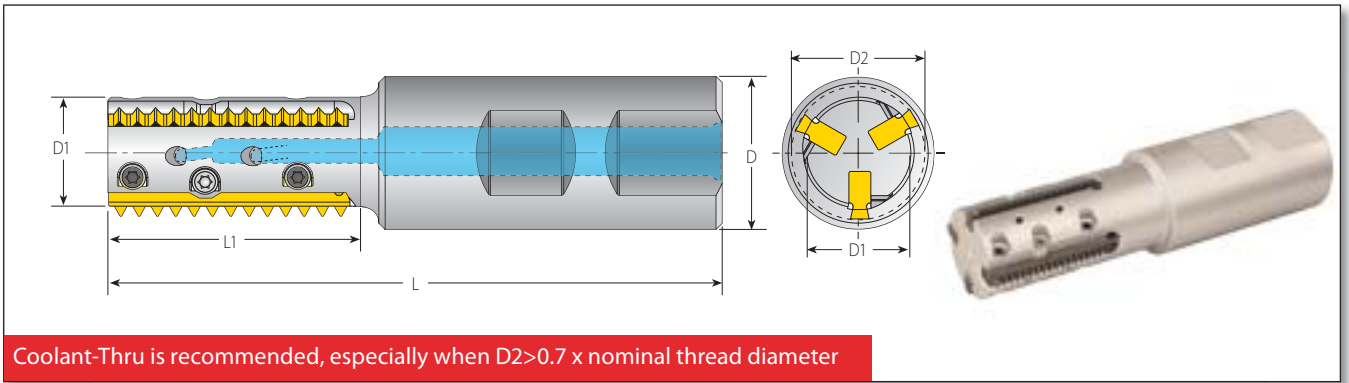

RTMC - for Standard Threads

Insert Style	Ordering Code	Dimensions mm						No. of Flutes	Spare Parts		
		L	L1	D	D1	D2	Z		Location Screw	Clamping Screw x2	Torx+ Screwdriver
40	RTMC2522-43L3	102	43	25	18	22	3	SLD4IP8A (M4x0.7)	SCD4IP8 (M4x0.7)	Torx+ Screwdriver KIP8 Use the included Vardex Torx+ screwdriver only. Recommended max. torque 1.2 NxM	
	RTMC2522-65L3	124	65	25	18	22	3				
	RTMC3230-55L4	117	55	32	26	30	4				
	BRTMC3230-80L3	142	80	32	26	30	3				

Standard Thread Application by Toolholder

Toolholder	Min. Thread Dia.						
	D2 (mm)	ISO (coarse)	ISO (fine)	UNC	UN/UNF/UNEF/UNS	BSF	BSP(G)
RTMC2522-43L3	22	M27x3	M24x1; M24x1.5 M25x2; M25x2.5	-	1 ¹ / ₁₆ -8UN; 1-9UN; 1-10UNS; 1-12UNF; 1-14UNS; 1-16UN; 1-18UN; 1 ¹ / ₁₆ -20UNEF	1-11; 1-12; 1-14; 1-16;	3/4-14
RTMC2522-65L3	22	M27x3	M24x1; M24x1.5 M25x2; M25x2.5	-	1 ¹ / ₁₆ -8UN; 1-9UN; 1-10UNS; 1-12UNF; 1-14UNS; 1-16UN; 1-18UN; 1 ¹ / ₁₆ -20UNEF	1-11; 1-12; 1-14; 1-16;	3/4-14
RTMC3230-55L4	30	-	M32x1; M32x1.5 M33x2; M33x2.5; M34x3	-	1 ³ / ₈ -8UN; 1 ³ / ₈ -9UN; 1 ³ / ₈ -10UN; 1 ¹ / ₁₆ -12UN; 1 ³ / ₈ -14UNS; 1 ¹ / ₁₆ -16UN; 1 ¹ / ₁₆ -18UNEF; 1 ¹ / ₁₆ -20UN	1 ³ / ₈ -11; 1 ³ / ₈ -12; 1 ³ / ₈ -14; 1 ³ / ₈ -16	1-11
BRTMC3230-80L3	30	-	M32x1; M32x1.5 M33x2; M33x2.5; M34x3	-	1 ³ / ₈ -8UN; 1 ³ / ₈ -9UN; 1 ³ / ₈ -10UN; 1 ¹ / ₁₆ -12UN; 1 ³ / ₈ -14UNS; 1 ¹ / ₁₆ -16UN; 1 ¹ / ₁₆ -18UNEF; 1 ¹ / ₁₆ -20UN	1 ³ / ₈ -11; 1 ³ / ₈ -12; 1 ³ / ₈ -14; 1 ³ / ₈ -16	1-11



2 Step Clamping System

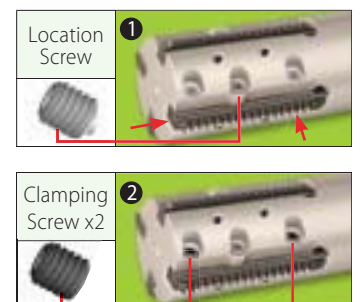

Shell Mill (MiTM 40)

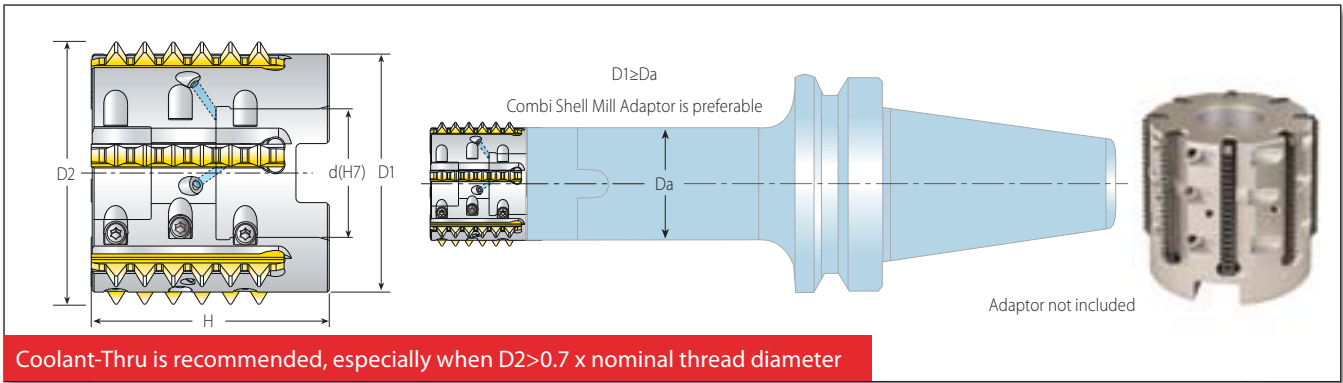

Conical and Standard Shell Mills

Spare Parts

Insert Style	Ordering Code	Dimensions mm				No. of Flutes	Spare Parts					
		D1	D2	d(H7)	H		Z	Location Screw	Clamping Screw x2	Torx+ Screwdriver	Holder Screw	
Standard	40	RTMC-D44-22-40L6	40	44	22	48	6	SLD4IP8A (M4x0.7)	SCD4IP8 (M4x0.7)	Torx+ Screwdriver	KIP8 Use the included Vardex Torx+ screwdriver only. Recommended max. torque 1.2 Nm	M10x1.5x40
	RTMC-D52-27-40L8	48	52	27	50	8	M12x1.75x40					
Conical	RTMNC-D45-22-40L6	40	45	22	48	6	M10x1.5x40					

Standard Thread Application by Toolholder

Toolholder		Min. Thread Dia.				
	D2 (mm)	ISO (fine)	UN/UNF/UNEF/UNS	BSW	BSP(G)	
Standard	RTMC-D44-22-40L6	44	M48x1; M48x1.5; M48x2; M48x3	1 7/8-12UN; 1 3/16-16UN; 1 3/16-20UN; 1 5/16-8UN; 1 7/8-10UNS; 1 7/8-14UNS	2-16 2-12	1 1/2-11
	RTMC-D52-27-40L8	52	M55x1; M55x1.5; M55x2; M56x3	2 1/4-8UN; 2 1/4-10UN; 2 1/4-12UN; 2 1/4-14UN; 2 1/4-16UN; 2 1/4-18UN; 2 1/4-20UN	2 1/4-16 2 1/4-12	2-11

Conical Thread Application by Toolholder

Toolholder		Min. Thread Dia.			
	D2 (mm)	NPT	NPTF	BSPT	
Conical	RTMNC-D45-22-40L6	45	2-11.5; 2 1/2-8 (and up)	2-11.5; 2 1/2-8; 3-8	2-6x11

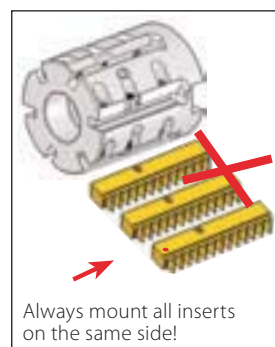
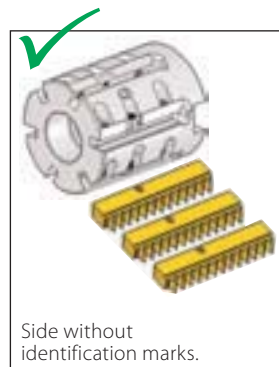
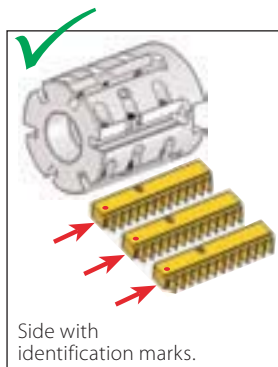

2 Step Clamping System

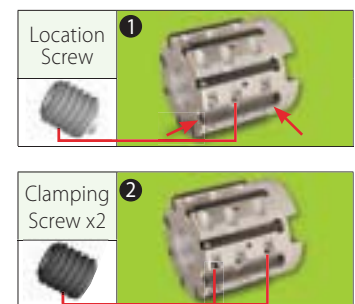

Standard Toolholders (MiTM 41)

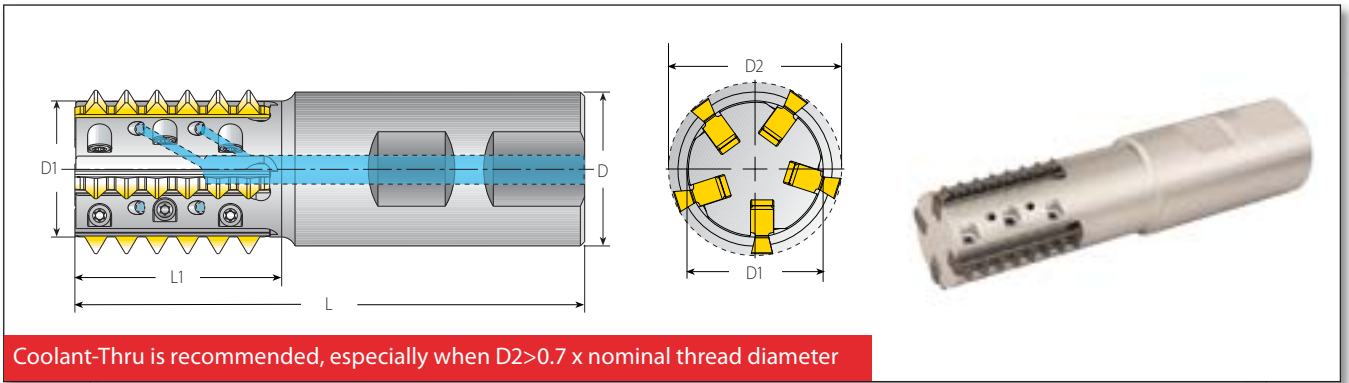

Coolant-Thru is recommended, especially when $D2 > 0.7 \times$ nominal thread diameter

RTMC - for Standard Threads

Spare Parts

Insert Style	Ordering Code	Dimensions mm						No. of Flutes	Location Screw x2	Clamping Screw	Torx+ Screwdriver
		L	L1	D	D1	D2*	Z				
41	RTMC2521-45B1	105	45	25	16.0	21.2	1	SLD4IP8A (M4x0.7)	SCD4IP8 (M4x0.7)	Use the included Vardex Torx+ screwdriver only. Recommended max. torque 1.2 NxM	
	RTMC2524-43B2	104	43	25	19.2	24.5	2				
	RTMC3230-43B3	106.5	43	32	24.2	30.0	3				
	RTMC3230-65B3	128.5	65	32	24.2	30.0	3				
	RTMC3236-43B5	106	43	32	28.3	35.9	5				
	RTMC3236-65B4	128	65	32	28.3	35.9	4				

Standard Thread Application by Toolholder

Toolholder	D2* (mm)	Min. Thread Dia.						
		ISO (coarse)	ISO (fine)	UNC	UN/UNF/UNEF/UNS	BSW/BSF	NPT	NPTF
RTMC2521-45B1	21.2	M27x3; M30x3.5; M33x3.5; M36x4; M39x4	M30x3; M42x4	1-8, 1 1/8-7; 1 1/4-7; 1 3/8-6; 1 1/2-6	1 1/16-8UN; 1 7/16-6UN	1-8BSW; 1 1/8-7BSW	-	-
RTMC2524-43B2	24.5	M30x3.5; M36x4	M28x3; M45x4	1 1/8-7; 1 3/8-6	1 1/8-8UN; 1 7/16-6UN	1 3/8-8BSF; 1 1/4-7BSW	-	-
RTMC3230-43B3	30.0	M36x4; M42x4.5	M34x3; M34x3.5; M45x4	1 3/8-6	1 3/8-8UN; 1 7/16-6UN	1 3/8-8BSF; 1 3/4-7BSF; 1 1/2-6BSW	-	-
RTMC3230-65B3	30.0	M36x4; M42x4.5	M34x3; M34x3.5; M45x4	1 3/8-6	1 3/8-8UN; 1 7/16-6UN	1 3/8-8BSF; 1 3/4-7BSF; 1 1/2-6BSW	-	-
RTMC3236-43B5	35.9	M42x4.5; M48x5; M56x5.5; M64x6	M40x3; M40x3.5; M42x4; M70x6	1 3/4-5; 2-4.5; 2 1/2-4	1 5/8-8UN; 1 5/8-6UN	1 5/8-8BSF; 1 3/4-7BSF; 1 5/8-6BSF	2 1/2-8	2 1/2-8
RTMC3236-65B4	35.9	M42x4.5; M48x5; M56x5.5; M64x6	M40x3; M40x3.5; M42x4; M70x6	1 3/4-5; 2-4.5; 2 1/2-4	1 5/8-8UN; 1 5/8-6UN	1 5/8-8BSF; 1 3/4-7BSF; 1 5/8-6BSF	2 1/2-8	2 1/2-8

* For external applications, inserts R41E... use for CNC program (D2+0.6mm).

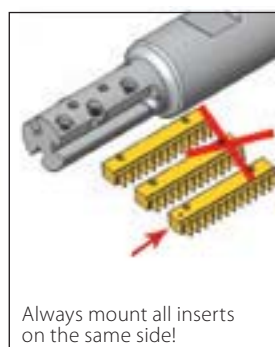
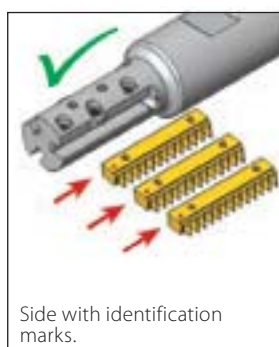

2 Step Clamping System

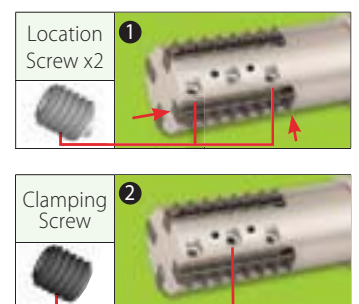

Shell Mill (MiTM 41)

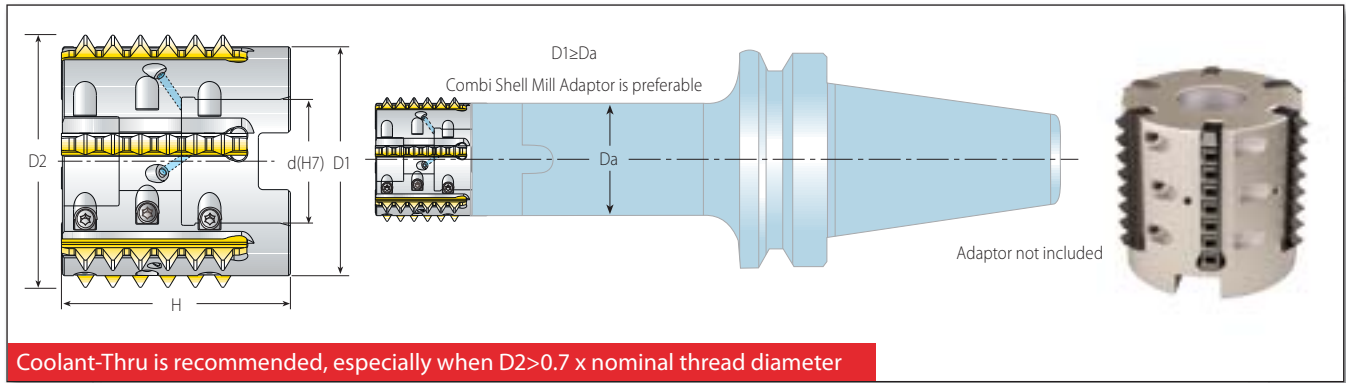

MiTM

Standard Shell Mill

Insert Style	Ordering Code	Dimensions mm					No. of Flutes	Spare Parts			
		D1	D2*	d(H7)	H	Z		Location Screw x2	Clamping Screw	Torx+ Screwdriver	Holder Screw
mm		D1	D2*	d(H7)	H	Z					
41	RTMC-D48-22-41B5	40	47.9	22	50	5	SLD4IP8A (M4x0.7)	SCD4IP8 (M4x0.7)	KIP8 Use the included Vardex Torx+ screwdriver only. Recommended max. torque 1.2 NxM	M10x1.5x40	
	RTMC-D58-27-41B6	50	57.9	27	50	6				M12x1.75x40	

Standard Thread Application by Toolholder

Toolholder	Min. Thread Dia.								
	D2* (mm)	ISO (coarse)	ISO (fine)	UNC	UN/UNF/UNEF/UNS	BSF	NPT	NPTF	
RTMC-D48-22-41B5	47.9	M56x5.5; M64x6	M55x4; M70x6;	2 1/4-4.5; 2 1/2-4	2 1/8-8UN; 2 1/8-6UN	2 1/4-8; 2 1/4-6	2 1/2-8	2 1/2-8	
RTMC-D58-27-41B6	57.9	M68x6	M64x4; M70x6	2 3/4-4	2 1/2-8UN; 2 1/2-6UN	2 1/2-8; 2 3/4-6	2 1/2-8	2 1/2-8	

* For external applications, inserts R41E... use for CNC program (D2+0.6mm).

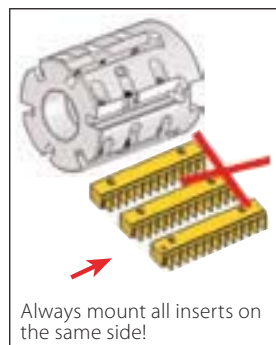
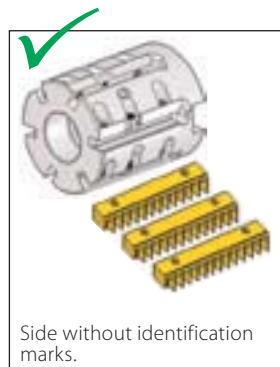
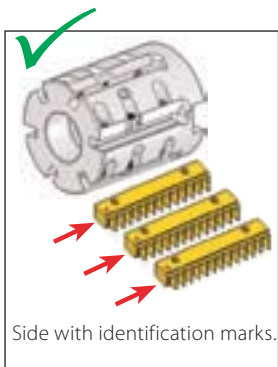

2 Step Clamping System

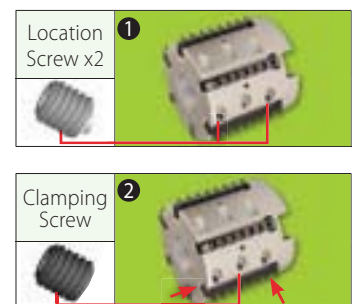



Recommended Grades, Cutting Speeds Vc [m/min] and Feed f [mm/tooth]

Material Group	Vargus No.	Material	Hardness Brinell HB	Vc [m/min]		Feed f [mm/tooth]		
				VBX	VTX	(Excluding MiTM 19)	(for MiTM 19)	
P Steel	1	Unalloyed Steel	Low Carbon (C=0.1-0.25%)	125	100-210	90-180	0.1-0.35	0.06-0.2
	2		Medium Carbon (C=0.25-0.55%)	150	100-180	90-170	0.1-0.4	0.06-0.25
	3		High Carbon (C=0.55-0.85%)	170	100-170	90-160	0.1-0.35	0.06-0.2
	4	Low Alloy Steel (alloying elements ≤5%)	Non Hardened	180	80-140	90-155	0.1-0.4	0.06-0.25
	5		Hardened	275	80-150	80-160	0.1-0.35	0.06-0.2
	6	High Alloy Steel (alloying elements >5%)	Hardened	350	70-140	70-150	0.1-0.3	0.06-0.2
	7		Annealed	200	60-130	70-115	0.1-0.35	0.06-0.2
	8		Hardened	325	70-110	60-100	0.1-0.2	0.06-0.1
	9	Cast Steel	Low Alloy (alloying elements <5%)	200	100-170	100-170	0.1-0.3	0.06-0.2
	10		High Alloy (alloying elements >5%)	225	70-120	70-130	0.1-0.2	0.06-0.1
M Stainless Steel	11	Stainless Steel Ferritic	Non Hardened	200	100-170	120-180	0.1-0.3	0.06-0.2
	12		Hardened	330	100-170	120-180	0.1-0.2	0.06-0.1
	13	Stainless Steel Austenitic	Austenitic	180	70-140	100-140	0.1-0.3	0.06-0.2
	14		Super Austenitic	200	70-140	100-140	0.1-0.2	0.06-0.1
	15	Stainless Steel Cast Ferritic	Non Hardened	200	70-140	100-140	0.1-0.3	0.06-0.2
	16		Hardened	330	70-140	100-140	0.1-0.2	0.06-0.1
	17	Stainless Steel Cast Austenitic	Austenitic	200	70-120	100-120	0.1-0.3	0.06-0.2
	18		Hardened	330	70-120	100-120	0.1-0.2	0.06-0.1
K Cast Iron	28	Malleable Cast Iron	Ferritic (short chips)	130	60-130	100-120	0.05-0.16	0.03-0.1
	29		Pearlitic (long chips)	230	60-120	80-100	0.04-0.1	0.02-0.06
	30	Grey Cast Iron	Low Tensile Strength	180	60-130	80-100	0.1-0.3	0.06-0.2
	31		High Tensile Strength	260	60-100	80-100	0.1-0.2	0.06-0.1
	32	Nodular Sg Iron	Ferritic	160	60-125	80-100	0.1-0.3	0.06-0.2
33	Pearlitic		260	50-90	60-90	0.1-0.2	0.06-0.1	
N Non-Ferrous Metals	34	Aluminium Alloys Wrought	Non Aging	60	100-250	-	0.15-0.55	0.09-0.3
	35		Aged	100	100-180	-	0.15-0.5	0.09-0.3
	36	Aluminium Alloys	Cast	75	150-400	-	0.15-0.5	0.09-0.3
	37		Cast & Aged	90	150-280	-	0.1-0.4	0.06-0.25
	38	Aluminium Alloys	Cast Si 13-22%	130	80-150	-	0.15-0.5	0.09-0.3
	39	Copper and Copper Alloys	Brass	90	120-210	100-200	0.15-0.5	0.09-0.3
40	Bronze And Non Leaded Copper		100	120-210	100-200	0.1-0.4	0.06-0.25	
S Heat Resistant Material	19	High Temperature Alloys	Annealed (iron based)	200	20-45	20-40	0.1-0.2	0.06-0.1
	20		Aged (iron based)	280	20-30	20-30	0.04-0.1	0.02-0.06
	21		Annealed (nickel or cobalt based)	250	15-20	15-20	0.04-0.1	0.02-0.06
	22		Aged (nickel or cobalt based)	350	10-15	10-15	0.04-0.1	0.02-0.06
	23	Titanium Alloys	Pure 99.5 Ti	400Rm	70-140	70-120	0.04-0.1	0.02-0.06
24	α+β Alloys		1050Rm	20-50	20-50	0.04-0.1	0.02-0.06	
H Hardened Material	25	Extra Hard Steel	Hardened & Tempered	45-50HRc	15-45	15-45	0.06-0.12	0.04-0.07
	26			51-55HRc	15-40	15-40	0.04-0.08	0.02-0.05

MiTM

Grades

Grade	Application	Sample
VBX	TiCN coated carbide grade. Excellent grade for steels and general use.	
VTX	TiAlN coated carbide grade. Ideal for Stainless Steels.	



STANDARD

Thread Milling

Inserts | Toolholders

Vardex Ordering Code System

■ Thread Milling Inserts

3	B	I	1.5	ISO	TM2	F	VBX	028/...
1	2	3	4	5	6	7	8	9

1 - Insert Size 6.0 - 6.0 mm 2 - 1/4" 3 - 3/8" 3B - 3/8"B 4 - 1/2" 5 - 5/8" 6B - 3/4"B	2 - Cutting Edge Length B - TMB	3 - Type of Insert E - External I - Internal EI - External + Internal	4 - Pitch 0.35 - 6.0
--	---	---	--------------------------------

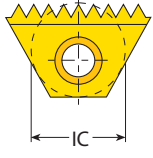

5 - Standard ISO- ISO Metric UN- American UN UNJ- UNJ W- Whitworth for BSW, BSP NPT - NPT NPTF- NPTF NPS- NPS	BSPT- British Standard Pipe Thread PG- Pg DIN 40430 ACME- ACME TR- Trapez DIN 103	6 - System TM2 TM	8 - Carbide Grade VBX VTX VK2
		7 - Pitch Type F = Fine Pitch	9 - Coarse Pitch Inserts 028/...

TM Standard

■ Thread Milling Toolholders

B	TM	N	C	20	-	3	B	LH	-	10
1	2	3	4	5		6	7	8	9	

1 - Shank Type B - Anti Vibration System	2 - System TM - Thread Milling	3 - Holder Type 2 - Twin Flute M - Mini L - Long Tool N - Tapered Holder V - Vertical Holder S - Single Point O - Offset W - Wide Cut. Dia.	4 - Cooling C - Coolant Channel
--	--	--	---

5 - Shank Dia. 10, 12, 16, 20, 25, 32, 40	6 - Insert Size 6.0 - 6.0mm 2 - 1/4" 3 - 3/8" 3B - 3/8"B 4 - 1/2" 5 - 5/8" 6B - 3/4"B	7 - Cut. Edge Length B - TMB	9 - RH / LH Holder None - Right Hand LH - Left Hand
		8 - Serial No. (for TMO Holders) 1 - 16	10 - Serial No. (for Coarse Pitch Holders) 124/...

■ Thread Milling Shell Mill

TMSH	-	D63	-	22	-	3	B
1		2		3		4	5

1 - System Thread Mill Shell Mill	2 - Cutting Dia. 38, 50, 63, 80, 100, 125	3 - Drive Hole Dia. 16, 22, 27, 32, 40	4 - Insert Size 2 - 1/4" 3 - 3/8" 3B - 3/8"B 5 - 5/8" 6B - 3/4"B
5 - Cut. Edge Length B - TMB			

Thread Milling Standard System

TMMC
 Miniature
 Applications



No. of Flutes (Z) 1
 Cutting Dia. (D2) 9.0
 Tool Overhang (L1) 12.0-17.0

TMC
 Standard
 Applications



No. of Flutes (Z) 1
 Cutting Dia. (D2) 9.0-46.0
 Tool Overhang (L1) 12.0-63.0

TMC 124/...
 Coarse Pitch
 Thread



No. of Flutes (Z) 1
 Cutting Dia. (D2) 9.0-22.0
 Tool Overhang (L1) 15.0-40.0

TMLC
 For Long Threads



No. of Flutes (Z) 1
 Cutting Dia. (D2) 11.5-46.0
 Tool Overhang (L1) 17.0-93.0

TMNC
 For Conical
 Applications



No. of Flutes (Z) 1
 Cutting Dia. (D2) 15.5-37.0
 Tool Overhang (L1) 22.0-58.0

TM2C
 Fast Infeed



No. of Flutes (Z) 2
 Cutting Dia. (D2) 17.0-52.0
 Tool Overhang (L1) 20.0-65.0

TMOC
 For Fewer
 Cycles



No. of Flutes (Z) 1
 Cutting Dia. (D2) 14.5-30.0
 Tool Overhang (L1) 25.0-52.0

TMSH
 Fast Machining in Large
 Diameters and Deep Holes



No. of Flutes (Z) 6-9
 Cutting Dia. (D2) 38.0-125.0
 Tool Overhang (L1) Max. 200

TMSC
 For Short Threads
 Economical
 Solutions



No. of Flutes (Z) 1
 Cutting Dia. (D2) 12.5
 Tool Overhang (L1) 25.0

TMVC
 For Large Pitches



No. of Flutes (Z) 1
 Cutting Dia. (D2) 46.0
 Tool Overhang (L1) 60.0

ISO Metric

External / Internal

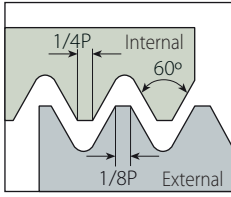

Defined by: R262 (DIN 13)
Tolerance class: 6g/6H

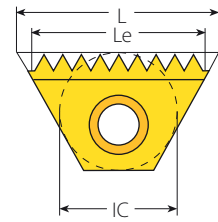

Standard TM

Standard TM

Insert Size		Pitch	Ordering Code		Le	Teeth	Toolholder
IC	L mm	mm	External	Internal	mm		
6.0mm	10.4	0.5		6.0I0.5ISOTM...	10.0	20	TMMC...-6.0
		0.75		6.0I0.75ISOTM...	9.75	13	
		1.0		6.0I1.0ISOTM...	9.0	9	
		1.25		6.0I1.25ISOTM...	8.75	7	
		1.5		6.0I1.5ISOTM...	9.0	6	
1/4"	11	0.5		2I0.5ISOTM2...	10.0	20	TMC...-2 TMSH...-2
		0.75	2E0.75ISOTM2...	2I0.75ISOTM2...	10.5	14	
		1.0	2E1.0ISOTM2...	2I1.0ISOTM2...	10.0	10	
		1.25	2E1.25ISOTM2...		10.0	8	
		1.25		2I1.25ISOTM2...	8.75	7	
		1.5	2E1.5ISOTM2...		9.0	6	
		1.5		2I1.5ISOTM2...	10.5	7	
3/8"	16	0.5		3I0.5ISOTM2...	15.0	30	TMC...-3 TMSH...-3
		0.75	3E0.75ISOTM2...	3I0.75ISOTM2...	15.0	20	
		0.8		3I0.8ISOTM2...	14.4	18	
		1.0	3E1.0ISOTM2...		14.0	14	
		1.0		3I1.0ISOTM2...	15.0	15	
		1.25	3E1.25ISOTM2...	3I1.25ISOTM2...	15.0	12	
		1.5	3E1.5ISOTM2...	3I1.5ISOTM2...	15.0	10	
		1.75	3E1.75ISOTM2...	3I1.75ISOTM2...	14.0	8	
3/8"B	22	1.0	3BE1.0ISOTM2...	3BI1.0ISOTM2...	22.0	22	BTMC...-3B TMSH...-3B
		1.25	3BE1.25ISOTM2...	3BI1.25ISOTM2...	21.25	17	
		1.5	3BE1.5ISOTM2...	3BI1.5ISOTM2...	21.0	14	
		1.75	3BE1.75ISOTM2...	3BI1.75ISOTM2...	21.0	12	
		2.0	3BE2.0ISOTM2...	3BI2.0ISOTM2...	22.0	11	
5/8"	27	1.0	5E1.0ISOTM2...	5I1.0ISOTM2...	26.0	26	TMC...-5 TMSH...-5
		1.25	5E1.25ISOTM2...	5I1.25ISOTM2...	25.0	20	
		1.5	5E1.5ISOTM2...	5I1.5ISOTM2...	25.5	17	
		1.75	5E1.75ISOTM2...	5I1.75ISOTM2...	24.5	14	
		2.0	5E2.0ISOTM2...	5I2.0ISOTM2...	24.0	12	
		2.5	5E2.5ISOTM2...	5I2.5ISOTM2...	25.0	10	
		3.0	5E3.0ISOTM2...	5I3.0ISOTM2...	24.0	8	
		3.5	5E3.5ISOTM2...	5I3.5ISOTM2...	24.5	7	
		4.0	5E4.0ISOTM2...	5I4.0ISOTM2...	24.0	6	
4.5	5E4.5ISOTM2...	5I4.5ISOTM2...	22.5	5			

All inserts have 2 cutting edges, except MiniTM (IC 6.0 mm) which has one cutting edge.

ISO Metric (con't)

External / Internal

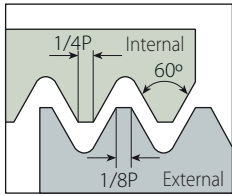

Defined by: R262 (DIN 13)
Tolerance class: 6g/6H

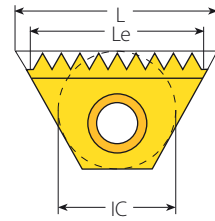

Standard TM

Standard TM

Insert Size		Pitch	Ordering Code		Le	Teeth	Toolholder
IC	L mm	mm	External	Internal	mm		
3/4"B	38.5	1.5	6BE1.5ISOTM2...	6BI1.5ISOTM2...	36.0	24	TMC.-6B TMSH.-6B
		2.0	6BE2.0ISOTM2...	6BI2.0ISOTM2...	36.0	18	
		2.5	6BE2.5ISOTM2...	6BI2.5ISOTM2...	35.0	14	
		3.0	6BE3.0ISOTM2...	6BI3.0ISOTM2...	36.0	12	
		4.0	6BE4.0ISOTM2...	6BI4.0ISOTM2...	32.0	8	
		4.5	6BE4.5ISOTM2...	6BI4.5ISOTM2...	31.5	7	
		5.0	6BE5.0ISOTM2...	6BI5.0ISOTM2...	30.0	6	
		5.5	6BE5.5ISOTM2...	6BI5.5ISOTM2...	33.0	6	
		6.0	6BE6.0ISOTM2...	6BI6.0ISOTM2...	30.0	5	

ISO Metric (con't)

Internal

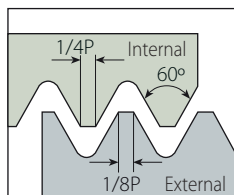

Defined by: R262 (DIN 13)
Tolerance class: 6g/6H

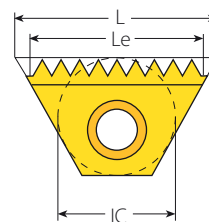

Coarse Pitch TM

Coarse Pitch TM

Thread	Insert Size		Ordering Code	Cutting Edge	Le	Teeth	Toolholder	Bore Dia. Range
	IC	L mm						
M10 X 0.75	6.0 mm	10.4	6.0I0.75ISOTM...028/001	1	9.75	13	TMMC12-6.0	9.1-10
M10 X 0.75			6.0I0.75ISOTM...028/001	1	9.75	13	TMMC20-6.0	9.1-10
M12 X 1.25			6.0I1.25ISOTM...028/002	1	8.75	7	TMMC12-6.0	10.6-11.4
M12 X 1.25			6.0I1.25ISOTM...028/002	1	8.75	7	TMMC20-6.0	10.6-11.4
M12 X 1.75			6.0I1.75ISOTM...028/003	1	8.75	5	TMMC20-6.0-124/003	10.1-19
M14 X 2.0			1/4"	11	2I2.0ISOTM...028/004	2	10.0	5
M14 X 2.0	2I2.0ISOTM...028/004	2			10.0	5	TMC20-2	11.8-19.5
M16 X 2.0	2I2.0ISOTM...028/004	2			10.0	5	TMC12-2	11.8-19.5
M16 X 2.0	2I2.0ISOTM...028/004	2			10.0	5	TMC20-2	11.8-19.5
M20 X 2.5	3/8"	16	3I2.5ISOTM...028/005	1	12.5	5	TMC16-3-124/001	17.2-19.2
M22 X 2.5	1/2"	22	4I2.5ISOTM...028/006	1	17.5	7	TMC25-4-124/002	19.2-31.6
M24 X 3.0			4I3.0ISOTM...028/007	1	18.0	6	TMC25-4-124/002	20.7-32.7
M27 X 3.0			4I3.0ISOTM...028/007	1	18.0	6	TMC25-4-124/002	20.7-32.7
M30 X 3.5			5I3.5ISOTM...028/008	2	24.5	7	TMC25-5-124/004	26.2-35.9
M33 X 3.5	5/8"	27	5I3.5ISOTM...028/008	2	24.5	7	TMC25-5-124/004	26.2-35.9
M36 X 3.0			5I3.0ISOTM...028/009	2	24.0	8	TMC25-5	32.7-39
M36 X 4.0			5I4.0ISOTM...028/010	2	24.0	6	TMC25-5	31.6-38.5
M39 X 3.0			5I3.0ISOTM...028/009	2	24.0	8	TMC25-5	32.7-39
M39 X 4.0			5I4.0ISOTM...028/010	2	24.0	6	TMC25-5	31.6-38.5
M42 X 4.5			5I4.5ISOTM...028/011	2	22.5	5	TMC25-5	37.1-48
M45 X 4.5			5I4.5ISOTM...028/011	2	22.5	5	TMC25-5	37.1-48
M48 X 5.0			5I5.0ISOTM...028/075	2	20.0	4	TMC25-5	38.9-∞
M52 X 5.0			5I5.0ISOTM...028/075	2	20.0	4	TMC25-5	38.9-∞

For Toolholder information, see page 284.

ISO Metric (con't)

External / Internal

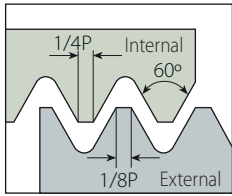

Defined by: R262 (DIN 13)
Tolerance class: 6g/6H

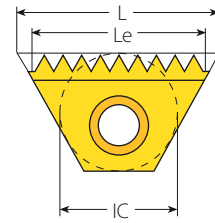

Standard TM

Standard TM Inserts for TMO Toolholders

Insert Size		Pitch	Ordering Code			ECL
IC	L mm	mm	External	Internal	Toolholder	mm
1/4"	11	0.5		2I0.5ISOTM2...	TMOC20-2-8	19.0
		0.75	2E0.75ISOTM2...	2I0.75ISOTM2...	TMOC20-2-9	19.5
		1.0	2E1.0ISOTM2...	2I1.0ISOTM2...	TMOC20-2-8	19.0
		1.25	2E1.25ISOTM2...		TMOC20-2-10	18.7
		1.25		2I1.25ISOTM2...	TMOC20-2-10	16.2
		1.5	2E1.5ISOTM2...		TMOC20-2-8	18.0
		1.5		2I1.5ISOTM2...	TMOC20-2-8	19.5
3/8"	16	0.5		3I0.5ISOTM2...	TMOC20-3-1	28.5
		0.5		3I0.5ISOTM2...	TMOC20-3-10	29.0
		0.75	3E0.75ISOTM2...	3I0.75ISOTM2...	TMOC20-3-11	28.5
		1.0	3E1.0ISOTM2...		TMOC20-3-10	28.0
		1.0		3I1.0ISOTM2...	TMOC20-3-10	29.0
		1.25	3E1.25ISOTM2...	3I1.25ISOTM2...	TMOC20-3-7	28.7
		1.5	3E1.5ISOTM2...	3I1.5ISOTM2...	TMOC20-3-1	28.5
		1.75	3E1.75ISOTM2...	3I1.75ISOTM2...	TMOC20-3-12	26.2
2.0	3E2.0ISOTM2...	3I2.0ISOTM2...	TMOC20-3-10	28.0		
5/8"	27	1.0	5E1.0ISOTM2...	5I1.0ISOTM2...	TMOC25-5-12	46.0
		1.0	5E1.0ISOTM2...	5I1.0ISOTM2...	TMOC25-5-16	47.0
		1.25	5E1.25ISOTM2...	5I1.25ISOTM2...	TMOC25-5-13	48.7
		1.5	5E1.5ISOTM2...	5I1.5ISOTM2...	TMOC25-5-14	48.0
		1.5	5E1.5ISOTM2...	5I1.5ISOTM2...	TMOC25-5-16	46.5
		1.75	5E1.75ISOTM2...	5I1.75ISOTM2...	TMOC25-5-15	47.2
		2.0	5E2.0ISOTM2...	5I2.0ISOTM2...	TMOC25-5-12	44.0
		2.5	5E2.5ISOTM2...	5I2.5ISOTM2...	TMOC25-5-12	45.0
		2.5	5E2.5ISOTM2...	5I2.5ISOTM2...	TMOC25-5-14	47.5
		3.0	5E3.0ISOTM2...	5I3.0ISOTM2...	TMOC25-5-16	45.0
		3.5	5E3.5ISOTM2...	5I3.5ISOTM2...	TMOC25-5-16	45.5
		4.0	5E4.0ISOTM2...	5I4.0ISOTM2...	TMOC25-5-12	44.0
		4.5	5E4.5ISOTM2...	5I4.5ISOTM2...	TMOC25-5-14	45.0
5.0		5I5.0ISOTM...028/075	TMOC25-5-12	40.0		

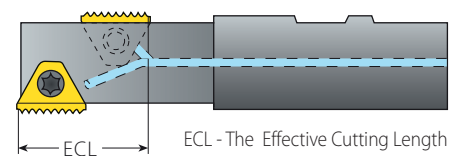

For Le and number of teeth of the above inserts, see the table for standard inserts on pages 256-257.
For Toolholder information, see page 289.

ISO Metric (con't)

External / Internal

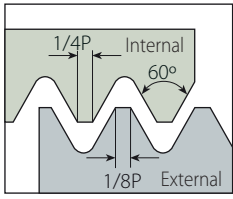

Defined by: R262 (DIN 13)
Tolerance class: 6g/6H

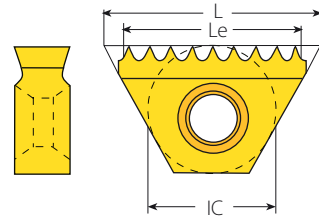

Fine Pitch TM

Fine Pitch TM

Insert Size		Pitch	Ordering Code		Le	Teeth	Toolholder
IC	L mm	mm	External	Internal	mm		
6.0mm	10.4	0.35	6.0E0.35ISOTMF...	6.0I0.35ISOTMF...	9.45	14	TMMC...-6.0
		0.4	6.0E0.4ISOTMF...	6.0I0.4ISOTMF...	9.2	12	
		0.45	6.0E0.45ISOTMF...	6.0I0.45ISOTMF...	9.45	11	
		0.5	6.0E0.5ISOTMF...		9.5	10	
		0.6	6.0E0.6ISOTMF...		9.0	8	
		0.7	6.0E0.7ISOTMF...		9.1	7	
		0.75	6.0E0.75ISOTMF...		8.25	6	
		0.8	6.0E0.8ISOTMF...		8.8	6	
		0.9	6.0E0.9ISOTMF...		8.1	5	
1/4"	11	0.35	2E0.35ISOTM2F...	2I0.35ISOTM2F...	10.15	15	TMC...-2 TMSH...-2
		0.4	2E0.4ISOTM2F...	2I0.4ISOTM2F...	10.0	13	
		0.45	2E0.45ISOTM2F...	2I0.45ISOTM2F...	9.45	11	
		0.5	2E0.5ISOTM2F...		9.5	10	
		0.6	2E0.6ISOTM2F...		10.2	9	
		0.7	2E0.7ISOTM2F...		9.1	7	
		0.8	2E0.8ISOTM2F...		8.8	6	
		0.9	2E0.9ISOTM2F...		9.9	6	
3/8"	16	0.35	3E0.35ISOTM2F...	3I0.35ISOTM2F...	14.35	21	TMC...-3 TMSH...-3
		0.4	3E0.4ISOTM2F...	3I0.4ISOTM2F...	14.8	19	
		0.45	3E0.45ISOTM2F...	3I0.45ISOTM2F...	14.85	17	
		0.5	3E0.5ISOTM2F...		13.5	14	
		0.6	3E0.6ISOTM2F...		13.8	12	
		0.7	3E0.7ISOTM2F...		14.7	11	
		0.8	3E0.8ISOTM2F...		13.6	9	
		0.9	3E0.9ISOTM2F...		13.5	8	

NOTE: Two orbits are required to complete the thread. Fine Pitch TM Inserts produce partial profile thread.

Sample order: **6.0E0.35ISOTMF VBX**

All inserts have 2 cutting edges, except MiniTM (IC 6.0 mm), which has one cutting edge.

For toolholder information, see page 280.

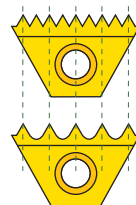

Fine Pitch Threads

Fine pitch threads are threads with small pitches. It is difficult to produce multitooth inserts for small pitches because of the small radius between the teeth. Vargus developed inserts where every second tooth was dropped to enlarge the radius between the teeth.

Important!

- All the fine pitch inserts are partial profile type (as a result of the enlarged radius).

American UN

External / Internal

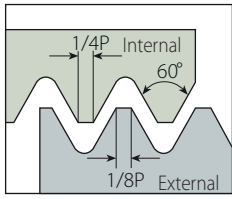

Defined by: ANSI B1.1.74
Tolerance class: Class 2A/2B

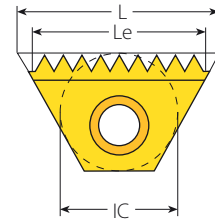

Standard TM

Standard TM

Insert Size		Pitch	Ordering Code		Le	Teeth	Toolholder
IC	L mm	tpi	External	Internal	mm		
6.0mm	10.4	32		6.0I32UNTM...	9.53	12	TMMC...-6.0
		28		6.0I28UNTM...	9.07	10	
		24		6.0I24UNTM...	9.53	9	
		20		6.0I20UNTM...	8.89	7	
		18		6.0I18UNTM...	8.47	6	
		16		6.0I16UNTM...	7.94	5	
1/4"	11	48		2I48UNTM2...	10.05	19	TMC...-2 TMSH...-2
		40		2I40UNTM2...	10.16	16	
		32		2I32UNTM2...	10.32	13	
		28	2E28UNTM2...	2I28UNTM2...	9.98	11	
		27	2E27UNTM2...	2I27UNTM2...	10.35	11	
		24	2E24UNTM2...	2I24UNTM2...	9.53	9	
		20	2E20UNTM2...	2I20UNTM2...	10.16	8	
		18	2E18UNTM2...	2I18UNTM2...	9.88	7	
3/8"	16	40		3I40UNTM2...	14.61	23	TMC...-3 TMSH...-3
		32		3I32UNTM2...	15.08	19	
		28	3E28UNTM2...	3I28UNTM2...	14.51	16	
		27	3E27UNTM2...	3I27UNTM2...	14.11	15	
		26	3E26UNTM2...	3I26UNTM2...	14.65	15	
		24	3E24UNTM2...	3I24UNTM2...	14.82	14	
		20	3E20UNTM2...	3I20UNTM2...	13.97	11	
		18	3E18UNTM2...	3I18UNTM2...	14.11	10	
		16	3E16UNTM2...	3I16UNTM2...	14.29	9	
		14	3E14UNTM2...	3I14UNTM2...	14.51	8	
		13	3E13UNTM2...	3I13UNTM2...	13.68	6	
		12	3E12UNTM2...	3I12UNTM2...	14.82	7	
3/8"B	22	24	3BE24UNTM2...	3BI24UNTM2...	21.16	20	BTMC...-3B TMSH...-3B
		20	3BE20UNTM2...	3BI20UNTM2...	21.59	17	
		18	3BE18UNTM2...	3BI18UNTM2...	21.17	15	
		16	3BE16UNTM2...	3BI16UNTM2...	20.64	13	
		14	3BE14UNTM2...	3BI14UNTM2...	21.77	12	
		13	3BE13UNTM2...	3BI13UNTM2...	21.49	11	
		12	3BE12UNTM2...	3BI12UNTM2...	21.17	10	

All inserts have 2 cutting edges, except Mini TM (IC 6.0 mm), which has one cutting edge.
For toolholder information, see page 280.

American UN (con't)

External / Internal

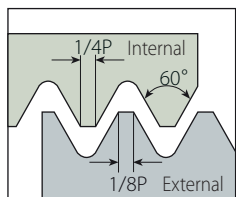

Defined by: ANSI B1.1.74
Tolerance class: Class 2A/2B

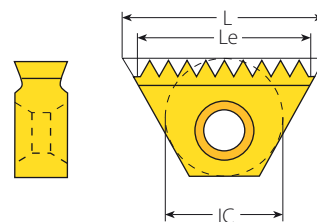

Standard TM

Standard TM

Insert Size		Pitch	Ordering Code		Le	Teeth	Toolholder
IC	L mm	tpi	External	Internal	mm		
5/8"	27	24	5E24UNTM2...	5I24UNTM2...	25.40	24	TMC..-5 TMSH..-5
		20	5E20UNTM2...	5I20UNTM2...	25.40	20	
		18	5E18UNTM2...	5I18UNTM2...	25.40	18	
		16	5E16UNTM2...	5I16UNTM2...	25.40	16	
		14	5E14UNTM2...	5I14UNTM2...	25.40	14	
		13	5E13UNTM2...	5I13UNTM2...	25.40	13	
		12	5E12UNTM2...	5I12UNTM2...	25.40	12	
		11.5	5E11.5UNTM2...	5I11.5UNTM2...	24.30	11	
		11	5E11UNTM2...	5I11UNTM2...	25.40	11	
		10	5E10UNTM2...		22.86	9	
		10		5I10UNTM2...	25.40	10	
		9	5E9UNTM2...	5I9UNTM2...	22.58	8	
		8	5E8UNTM2...	5I8UNTM2...	22.23	7	
		7	5E7UNTM2...		21.77	6	
		7		5I7UNTM2...	25.40	7	
		6	5E6UNTM2...		21.17	5	
6		5I6UNTM2...	25.40	6			
3/4"B	38.5	6	6BE6UNTM2...	6BI6UNTM2...	38.87	8	TMC..-6B TMSH..-6B
		5	6BE5UNTM2...	6BI5UNTM2...	30.48	6	
		4.5	6BE4.5UNTM2...	6BI4.5UNTM2...	33.87	6	
		4	6BE4UNTM2...	6BI4UNTM2...	31.75	5	

All inserts have 2 cutting edges, except MiniTM (IC 6.0 mm), which has one cutting edge.
For toolholder information, see page 280.

American UN (con't)

Internal

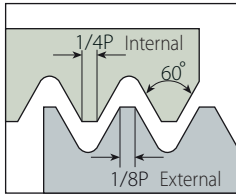

Defined by: ANSI B1.1.74
Tolerance class: Class 2A/2B

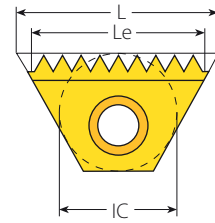

Coarse Pitch TM

Coarse Pitch TM

Thread	Insert Size		Ordering Code	Cutting Edge	Le	Teeth	Toolholder	Bore Dia. Range
	IC	L mm	Internal		mm			mm
7/16"-20UNF	6.0mm	10.4	6.0I20UNTM...028/012	1	8.89	7	TMMC12-6.0	9.7-11.4
7/16"-20UNF			6.0I20UNTM...028/012	1	8.89	7	TMMC20-6.0	9.7-11.4
7/16"-16UN			6.0I16UNTM...028/014	1	7.94	5	TMMC12-6.0	9.3-14.1
7/16"-16UN			6.0I16UNTM...028/014	1	7.94	5	TMMC20-6.0	9.3-14.1
7/16"-14UNC			6.0I14UNTM...028/013	1	9.07	5	TMMC20-6.0-124/003	9.1-9.9
1/2"-13UNC	1/4"	11	2I13UNTM...028/015	1	9.77	5	TMC20-2-124/005	10.5-19.5
1/2"-16UN	6.0mm	10.4	6.0I16UNTM...028/014	1	7.94	5	TMMC12-6.0	9.3-14.1
1/2"-16UN			6.0I16UNTM...028/014	1	7.94	5	TMMC20-6.0	9.3-14.1
9/16"-12UNC	1/4"	11	2I12UNTM...028/016	1	8.47	4	TMC20-2-124/005	11.9-15.6
9/16"-18UNF			2I18UNTM...028/017	2	9.88	7	TMC12-2	12.7-14.5
9/16"-18UNF			2I18UNTM...028/017	2	9.88	7	TMC20-2	12.7-14.5
9/16"-16UN	6.0mm	10.4	6.0I16UNTM...028/014	1	7.94	5	TMMC12-6.0	9.3-14.1
9/16"-16UN			6.0I16UNTM...028/014	1	7.94	5	TMMC20-6.0	9.3-14.1
5/8"-11UNC	1/4"	11	2I11UNTM...028/018	1	9.24	4	TMC20-2-124/006	13.3-18.5
5/8"-12UN			2I12UNTM...028/016	1	8.47	4	TMC20-2-124/005	11.9-15.6
5/8"-16UN	6.0mm	10.4	6.0I16UNTM...028/014	1	7.94	5	TMMC12-6.0	9.3-14.1
5/8"-16UN			6.0I16UNTM...028/014	1	7.94	5	TMMC20-6.0	9.3-14.1
11/16"-12UN	1/4"	11	2I12UNTM...028/016	1	8.47	4	TMC20-2-124/005	11.9-15.6
3/4"-10UNC	3/8"	16	3I10UNTM...028/019	1	12.70	5	TMC16-3-124/001	16.3-31.6
3/4"-12UN			3I12UNTM...028/020	2	14.82	7	TMNC16-3	16.7-18.3
13/16"-12UN			3I12UNTM...028/020	2	14.82	7	TMC16-3	18.3-19.5
7/8"-9UNC	1/2"	22	4I9UNTM...028/021	1	16.93	6	TMC25-4-124/002	19.1-32.5

For toolholder information, see page 280.

American UN (con't)

Internal





Defined by: ANSI B1.1.74
Tolerance class: Class 2A/2B

Coarse Pitch TM

Coarse Pitch TM

Thread	Insert Size		Ordering Code	Cutting Edge	Le	Teeth	Toolholder	Bore Dia. Range
	IC	L mm						
1"-8UNC	1/2"	22	4I8UNTM...028/022	1	19.05	6	TMC25-4-124/007	21.9-28.3
1 1/16"-8UN			4I8UNTM...028/022	1	19.05	6	TMC25-4-124/007	21.9-28.3
1 1/8"-7UNC			4I7UNTM...028/023	1	18.14	5	TMC25-4-124/002	24.6-35.9
1 1/8"-8UN			4I8UNTM...028/022	1	19.05	6	TMC25-4-124/007	21.9-28.3
1 3/16"-8UN			4I8UNTM...028/022	1	19.05	6	TMC25-4-124/007	21.9-28.3
1 1/4"-7UNC			4I7UNTM...028/023	1	18.14	5	TMC25-4-124/002	24.6-35.9
1 1/4"-8UN	5/8"	27	5I8UNTM...028/024	2	22.23	7	TMC25-5-124/004	28.3-33.0
1 5/16"-8UN			5I8UNTM...028/024	2	22.23	7	TMC25-5-124/004	28.3-33.0
1 3/8"-6UNC			5I6UNTM...028/025	2	25.40	6	TMC25-5-124/004	30.3-36.7
1 3/8"-8UN			5I8UNTM...028/024	2	22.23	7	TMC25-5-124/004	28.3-33.0
1 7/16"-6UN			5I6UNTM...028/025	2	25.40	6	TMC25-5-124/004	30.3-36.7
1 7/16"-8UN			5I8UNTM...028/024	2	22.23	7	TMC25-5	33.0-39.0
1 1/2"-6UNC			5I6UNTM...028/025	2	25.40	6	TMC25-5-124/004	30.3-36.7
1 1/2"-8UN			5I8UNTM...028/024	2	22.23	7	TMC25-5	33.0-39.0
1 9/16"-6UN			5I6UNTM...028/025	2	25.40	6	TMC25-5-124/004	30.3-36.7
1 9/16"-8UN			5I8UNTM...028/024	2	22.23	7	TMC25-5	33.0-39.0
1 5/8"-6UN			5I6UNTM...028/025	2	25.40	6	TMC25-5	36.7-45.0
1 5/8"-8UN			5I8UNTM...028/024	2	22.23	7	TMC25-5	33.0-39.0
1 11/16"-6UN			5I6UNTM...028/025	2	25.40	6	TMC25-5	36.7-45.0
1 3/4"-5UNC			5I5UNTM...028/077	2	20.32	4	TMC25-5	38.9-∞
1 3/4"-6UN	5I6UNTM...028/025	2	25.40	6	TMC25-5	36.7-45.0		
1 13/16"-6UN	5I6UNTM...028/025	2	25.40	6	TMC25-5	36.7-45.0		
1 7/8"-6UN	5I6UNTM...028/025	2	25.40	6	TMC25-5	36.7-45.0		
1 15/16"-6UN	5I6UNTM...028/025	2	25.40	6	TMC25-5	36.7-45.0		

For toolholder information, see page 280.

American UN (con't)

External / Internal

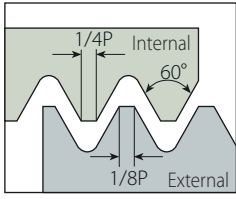

Defined by: ANSI B1.1.74
Tolerance class: Class 2A/2B

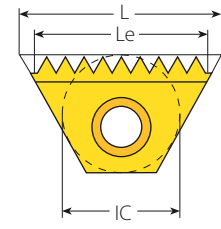

Standard TM

Standard TM Inserts for TMO Toolholders

Insert Size		Pitch	Ordering Code			ECL
IC	L mm	tpi	External	Internal	Toolholder	mm
1/4"	11	48		2I48UNTM2...	TMOC20-2-1	19.58
		48		2I48UNTM2...	TMOC20-2-2	18.52
		48		2I48UNTM2...	TMOC20-2-9	19.05
		32		2I32UNTM2...	TMOC20-2-1	19.85
		28	2E28UNTM2...	2I28UNTM2...	TMOC20-2-3	17.24
		24	2E24UNTM2...	2I24UNTM2...	TMOC20-2-2	17.99
		20	2E20UNTM2...	2I20UNTM2...	TMOC20-2-4	19.05
		18	2E18UNTM2...	2I18UNTM2...	TMOC20-2-2	18.34
		16	2E16UNTM2...	2I16UNTM2...	TMOC20-2-1	19.05
		14	2E14UNTM2...	2I14UNTM2...	TMOC20-2-3	16.33
3/8"	16	32		3I32UNTM2...	TMOC20-3-3	27.78
		32		3I32UNTM2...	TMOC20-3-11	28.58
		28	3E28UNTM2...	3I28UNTM2...	TMOC20-3-3	27.21
		27	3E27UNTM2...	3I27UNTM2...	TMOC20-3-4	27.28
		24	3E24UNTM2...	3I24UNTM2...	TMOC20-3-6	27.52
		20	3E20UNTM2...	3I20UNTM2...	TMOC20-3-6	26.67
		18	3E18UNTM2...	3I18UNTM2...	TMOC20-3-6	26.82
		16	3E16UNTM2...	3I16UNTM2...	TMOC20-3-6	26.99
		14	3E14UNTM2...	3I14UNTM2...	TMOC20-3-6	27.21
		13	3E13UNTM2...	3I13UNTM2...	TMOC20-3-2	25.4
		12	3E12UNTM2...	3I12UNTM2...	TMOC20-3-6	27.52
		11.5	3E11.5UNTM2...	3I11.5UNTM2...	TMOC20-3-5	24.3

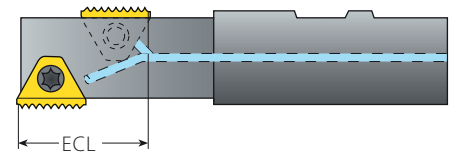

ECL - The Effective Cutting Length

For Le and number of teeth of the above inserts, see the table for standard inserts on pages 261-262.
For toolholder information, see page 289.

American UN (con't)

External / Internal

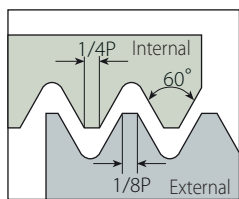

Defined by: ANSI B1.1.74
Tolerance class: Class 2A/2B

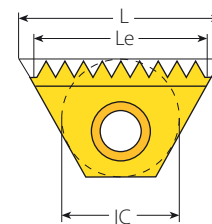

Standard TM

Standard TM Inserts for TMO Toolholders

Insert Size		Pitch	Ordering Code			ECL
IC	L mm	tpi	External	Internal	Toolholder	mm
5/8"	27	24	5E24UNTM2..	5I24UNTM2..	TMOC25-5-1	50.80
		24	5E24UNTM2...	5I24UNTM2...	TMOC25-5-2	46.57
		20	5E20UNTM2...	5I20UNTM2...	TMOC25-5-1	50.80
		18	5E18UNTM2...	5I18UNTM2...	TMOC25-5-1	50.80
		18	5E18UNTM2...	5I18UNTM2...	TMOC25-5-2	46.57
		16	5E16UNTM2...	5I16UNTM2...	TMOC25-5-3	47.63
		14	5E14UNTM2...	5I14UNTM2...	TMOC25-5-1	50.80
		14	5E14UNTM2...	5I14UNTM2...	TMOC25-5-4	47.17
		13	5E13UNTM2...	5I13UNTM2...	TMOC25-5-1	50.80
		12	5E12UNTM2...	5I12UNTM2...	TMOC25-5-2	46.57
		12	5E12UNTM2...		TMOC25-5-1	50.80
		11.5	5E11.5UNTM2...	5I11.5UNTM2...	TMOC25-5-5	46.38
		11	5E11UNTM2...	5I11UNTM2...	TMOC25-5-6	48.49
		11		5I11UNTM2...	TMOC25-5-1	46.18
		10	5E10UNTM2...		TMOC25-5-7	43.18
		10		5I10UNTM2...	TMOC25-5-7	45.72
		9	5E9UNTM2...	5I9UNTM2...	TMOC25-5-8	45.16
		8	5E8UNTM2...	5I8UNTM2...	TMOC25-5-9	44.45
		7	5E7UNTM2...		TMOC25-5-10	43.54
		7		5I7UNTM2...	TMOC25-5-10	47.17
6	5E6UNTM2...		TMOC25-5-2	42.33		
6		5I6UNTM2...	TMOC25-5-2	46.57		
5		5I5UNTM...028/077	TMOC25-5-7	40.64		

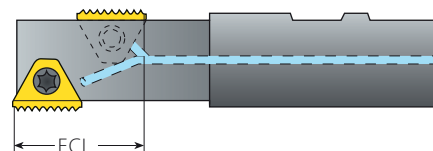

ECL - The Effective Cutting Length

For Le and number of teeth of the above inserts, see the table for standard inserts on pages 261-262.
For toolholder information, see page 289.

American UN (con't)

External / Internal

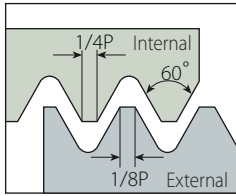

Defined by: ANSI B1.1.74
Tolerance class: Class 2A/2B

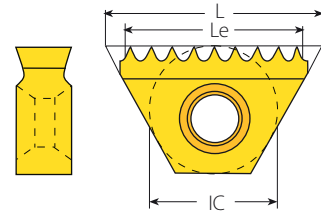

Fine Pitch TM

Fine Pitch TM

Insert Size		Pitch	Ordering Code		Le	Teeth	Toolholder
IC	L mm	tpi	External	Internal	mm		
6.0mm	10.4	80	6.0E80UNTMF...	6.0I80UNTMF...	9.84	16	TMMC...-6.0
		72	6.0E72UNTMF...	6.0I72UNTMF...	9.53	14	
		64	6.0E64UNTMF...	6.0I64UNTMF...	9.13	12	
		56	6.0E56UNTMF...	6.0I56UNTMF...	9.53	11	
		48	6.0E48UNTMF...		9.00	9	
		44	6.0E44UNTMF...		8.66	8	
		40	6.0E40UNTMF...		8.26	7	
		36	6.0E36UNTMF...		9.17	7	
1/4"	11	80	2E80UNTM2F...	2I80UNTM2F...	9.84	16	TMC...-2 TMSH...-2
		72	2E72UNTM2F...	2I72UNTM2F...	10.23	15	
		64	2E64UNTM2F...	2I64UNTM2F...	9.92	13	
		56	2E56UNTM2F...	2I56UNTM2F...	9.53	11	
		48	2E48UNTM2F...		10.05	10	
		44	2E44UNTM2F...		9.81	9	
		40	2E40UNTM2F...		9.53	8	
		36	2E36UNTM2F...		9.17	7	
3/8"	16	80	3E80UNTM2F...	3I80UNTM2F...	14.29	23	TMC...-3 TMSH...-3
		72	3E72UNTM2F...	3I72UNTM2F...	14.46	21	
		64	3E64UNTM2F...	3I64UNTM2F...	14.68	19	
		56	3E56UNTM2F...	3I56UNTM2F...	14.06	16	
		48	3E48UNTM2F...		14.29	14	
		44	3E44UNTM2F...		14.43	13	
		40	3E40UNTM2F...		14.61	12	
		36	3E36UNTM2F...		14.82	11	
		32	3E32UNTM2F...		13.49	9	

NOTE: Two orbits are required to complete the thread. Fine Pitch TM Inserts produce partial profile thread.

Sample order: **6.0E80UNTMF VBX**

All inserts have 2 cutting edges, except MiniTM (IC 6.0 mm), which has one cutting edge.

For toolholder information, see page 280.

Fine Pitch Threads

Fine pitch threads are threads with small pitches. It is difficult to produce multitooth inserts for small pitches because of the small radius between the teeth. Vargus developed inserts where every second tooth was dropped to enlarge the radius between the teeth.

Important!

- All the fine pitch inserts are partial profile type (as a result of the enlarged radius).

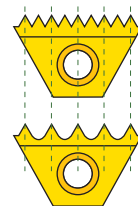

UNJ

External / Internal

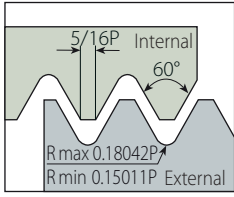

Defined by: MIL-S-8879C
Tolerance class: 3A/3B

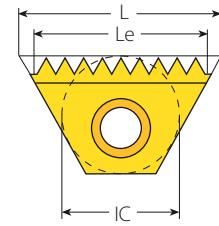

Standard TM

Standard TM

Insert Size		Pitch	Ordering Code		Le	Teeth	Toolholder
IC	L mm	tpi	External	Internal	mm		
6.0mm	10.4	24		6.0I24UNJTM...	9.53	9	TMMC...-6.0
		20		6.0I20UNJTM...	8.89	7	
		18		6.0I18UNJTM...	8.47	6	
		16		6.0I16UNJTM...	9.53	6	
1/4"	11	24	2E24UNJTM2...	2I24UNJTM2...	9.53	9	TMC...-2 TMSH...-2
		20	2E20UNJTM2...	2I20UNJTM2...	10.16	8	
		18	2E18UNJTM2...	2I18UNJTM2...	9.88	7	
		16	2E16UNJTM2...	2I16UNJTM2...	9.53	6	
		14	2E14UNJTM2...	2I14UNJTM2...	9.07	5	
3/8"	16	24	3E24UNJTM2...	3I24UNJTM2...	14.82	14	TMC...-3 TMSH...-3
		20	3E20UNJTM2...	3I20UNJTM2...	13.97	11	
		18	3E18UNJTM2...	3I18UNJTM2...	14.11	10	
		16	3E16UNJTM2...	3I16UNJTM2...	14.29	9	
		14	3E14UNJTM2...	3I14UNJTM2...	14.51	8	
		13	3E13UNJTM2...		13.68	7	
5/8"	27	16	5E16UNJTM2...	5I16UNJTM2...	25.40	16	TMC...-5 TMSH...-5
		12	5E12UNJTM2...	5I12UNJTM2...	25.40	12	
		11	5E11UNJTM2...	5I11UNJTM2...	25.40	11	

All inserts have 2 cutting edges, except MiniTM (IC 6.0 mm), which has one cutting edge.
For toolholder information, see page 280.

TM Standard

Whitworth for BSW, BSP

External / Internal

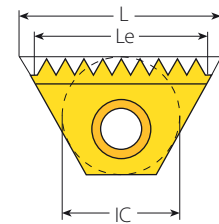
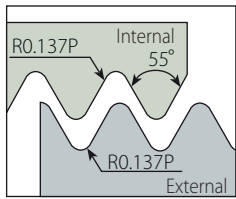

BSW Defined by: B.S.84:1956, DIN 259, ISO228/1:1982
 BSP Defined by: B.S.2779:1956
 Tolerance class: BSW-Medium class A, BSP-Medium class

Standard TM

Standard TM

Insert Size		Pitch	Ordering Code	Le	Teeth	Toolholder
IC	L mm	tpi	External + Internal	mm		
6.0mm	10.4	28	6.0EI28WTM...	9.07	10	TMMC...-6.0
		26	6.0EI26WTM...	8.79	9	
		24	6.0EI24WTM...	9.53	9	
		20	6.0EI20WTM...	8.89	7	
		19	6.0EI19WTM...	9.36	7	
1/4"	11	28	2EI28WTM2...	9.98	11	TMC...-2 TMSH...-2
		26	2EI26WTM2...	9.77	10	
		24	2EI24WTM2...	9.53	9	
		20	2EI20WTM2...	10.16	8	
		19	2EI19WTM2...	9.36	7	
3/8"	16	26	3EI26WTM2...	14.65	15	TMC...-3 TMSH...-3
		24	3EI24WTM2...	14.82	14	
		20	3EI20WTM2...	13.97	11	
		19	3EI19WTM2...	14.71	11	
		18	3EI18WTM2...	14.11	10	
		16	3EI16WTM2...	14.29	9	
		14	3EI14WTM2...	14.51	8	
		12	3EI12WTM2...	14.82	7	
3/8"B	22	11	3EI11WTM2...	13.85	6	TMC...-3B TMSH...-3B
		24	3BEI24WTM2...	21.17	20	
		20	3BEI20WTM2...	21.59	17	
		19	3BEI19WTM2...	21.39	16	
		18	3BEI18WTM2...	21.17	15	
		16	3BEI16WTM2...	20.64	13	
		14	3BEI14WTM2...	21.77	12	
5/8"	27	12	3BEI12WTM2...	21.17	10	TMC...-5 TMSH...-5
		11	3BEI11WTM2...	20.78	9	
		16	5EI16WTM2...	25.40	16	
		14	5EI14WTM2...	25.40	14	
		12	5EI12WTM2...	23.28	11	
		11	5EI11WTM2...	23.09	10	
		10	5EI10WTM2...	25.40	10	
		9	5EI9WTM2...	22.58	8	
3/4"B	38.5	8	5EI8WTM2...	22.23	7	TMC...-6B TMSH...-6B
		7	5EI7WTM2...	21.77	6	
		6	5EI6WTM2...	21.17	5	
		11	6BEI11WTM2...	34.64	15	
		6	6BEI6WTM2...	33.87	8	
		5	6BEI5WTM2...	30.48	6	
		4.5	6BEI4.5WTM2...	33.87	6	

All inserts have 2 cutting edges, except MiniTM (IC 6.0 mm) which has one cutting edge.
 For toolholder information, see page 280.

Whitworth for BSW only (con't)

Internal

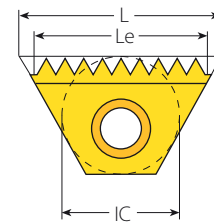
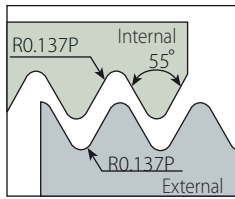

Defined by: B.S.84:1956, DIN259, ISO228/1:1982
Tolerance class: Medium class A

Coarse Pitch TM

Coarse Pitch TM

Thread	Insert Size		Ordering Code	Cutting Edge	Le	Teeth	Toolholder	Bore Dia. Range
Inch	IC	L mm	Internal		mm			mm
7/16"-18	6.0mm	10.4	6.0118WTM...028/035	1	8.47	6	TMMC12-6.0	9.3-14.2
7/16"-18			6.0118WTM...028/035	1	8.47	6	TMMC20-6.0	9.3-14.2
7/16"-26			6.0126WTM... 028/036	1	8.79	9	TMMC12-6.0	9.8-10.5
7/16"-26			6.0126WTM... 028/036	1	8.79	9	TMMC20-6.0	9.8-10.5
1/2"-16	1/4"	11	2116WTM... 028/051	1	9.53	6	TMC20-2-124/005	10.6-12.2
1/2"-20	6.0mm	10.4	6.0120WTM...028/037	1	8.89	7	TMMC12-6.0	11.0-11.4
1/2"-20			6.0120WTM...028/037	1	8.89	7	TMMC20-6.0	11.0-11.4
9/16"-16	1/4"	11	2116WTM...028/038	2	9.53	6	TMC12-2	12.2-18.5
9/16"-16			2116WTM...028/038	2	9.53	6	TMC20-2	12.2-18.5
5/8"-14			2114WTM...028/039	1	9.07	5	TMC20-2-124/006	13.5-19.0
11/16"-14			2114WTM...028/039	1	9.07	5	TMC20-2-124/006	13.5-19.0
11/16"-16	1/4"	11	2116WTM...028/038	2	9.53	6	TMC12-2	12.2-18.5
11/16"-16			2116WTM...028/038	2	9.53	6	TMC20-2	12.2-18.5
3/4"-12	3/8"	16	3112WTM...028/040	1	14.82	7	TMC16-3-124/001	16.3-17.9
3/4"-16	1/4"	11	2116WTM...028/038	2	9.53	6	TMC12-2	12.2-18.5
3/4"-16			2116WTM...028/038	2	9.53	6	TMC20-2	12.2-18.5
13/16"-12	3/8"	16	3112WTM...028/041	2	14.82	7	TMC16-3	17.9-21.0
7/8"-9	1/2"	22	419WTM...028/042	1	16.93	6	TMC25-4-124/002	18.6-32.5
7/8"-11			4111WTM...028/043	1	18.47	8	TMC25-4-124/002	19.2-22.0
15/16"-12	3/8"	16	3112WTM...028/041	2	14.82	7	TMC20-3	21.0-30.6
1"-8	1/2"	22	418WTM...028/044	1	15.88	5	TMC25-4-124/002	21.3-26.0
1"-10			4110WTM...028/045	1	17.78	7	TMC25-4-124/002	22.1-31.6
1"-12	3/8"	16	3112WTM...028/041	2	14.82	7	TMC20-3	21.0-30.6
1 1/16"-12			3112WTM...028/041	2	14.82	7	TMC20-3	21.0-30.6
1 1/8"-7	5/8"	27	517WTM...028/046	1	21.77	6	TMC25-5-124/008	23.9-27.1
1 1/8"-9	1/2"	22	419WTM...028/042	1	16.93	6	TMC25-4-124/002	18.6-32.5
1 1/8"-12	3/8"	16	3112WTM...028/041	2	14.82	7	TMC20-3	21.0-30.6
1 3/16"-8	5/8"	27	518WTM...028/047	2	22.23	7	TMC25-5-124/004	26.0-32.4
1 3/16"-12	3/8"	16	3112WTM...028/041	2	14.82	7	TMC20-3	21.0-30.6
1 1/4"-7	5/8"	27	517WTM...028/048	2	21.77	6	TMC25-5-124/004	21.7-35.9
1 1/4"-9	1/2"	22	419WTM...028/042	1	16.93	6	TMC25-4-124/002	18.6-32.5
1 1/4"-12	3/8"	16	3112WTM...028/041	2	14.82	7	TMC20-3	21.0-30.6
1 5/16"-6	5/8"	27	516WTM...028/049	2	21.17	5	TMC25-5-124/004	27.9-32.6
1 5/16"-8			518WTM...028/047	2	22.23	7	TMC25-5-124/004	26.0-32.4

For toolholder information, see page 280.

Whitworth for BSW only (con't)

Internal

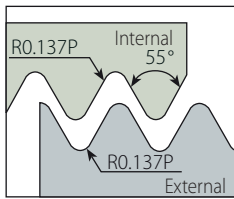

Defined by: B.S.84:1956, DIN259, ISO228/1:1982
Tolerance class: Medium class A

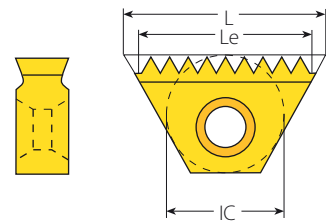

Coarse Pitch TM Inserts

Coarse Pitch TM

Thread	Insert Size		Ordering Code	Cutting Edge	Le	Teeth	Bore Dia. Range			
	IC	L mm					Internal	Toolholder	mm	
1 5/16"-12	3/8"	16	3I12WTM...028/041	2	14.82	7	TMC20-3	21.0-30.6		
1 3/8"-8			5I8WTM...028/047	2	22.23	7	TMC25-5-124/004	26.0-32.4		
1 3/8"-6			5I6WTM...028/049	2	21.17	5	TMC25-5-124/004	27.9-32.6		
1 3/8"-12			5I12WTM...028/050	2	23.28	11	TMC25-5	32.2-34.6		
1.4-6			5I6WTM...028/049	2	21.17	5	TMC25-5-124/004	27.9-32.6		
1.4-8			5I8WTM...028/047	2	22.23	7	TMC25-5-124/004	26.0-32.4		
1.4-12			5I12WTM...028/050	2	23.28	11	TMC25-5	32.2-34.6		
1 7/16"-6			5/8"	27	5I6WTM...028/049	2	21.17	5	TMC25-5-124/004	27.9-32.6
1 7/16"-8					5I8WTM...028/047	2	22.23	7	TMC25-5	32.4-39.0
1 7/16"-12					5I12WTM...028/050	2	23.28	11	TMC25-5	32.2-34.6
1 1/2"-6					5I6WTM...028/049	2	21.17	5	TMC25-5-124/004	27.9-32.7
1 1/2"-8					5I8WTM...028/047	2	22.23	7	TMC25-5	32.4-39.0
1.6-6					5I6WTM...028/049	2	21.17	5	TMC25-5	32.6-38.5
1.6-8					5I8WTM...028/047	2	22.23	7	TMC25-5	32.4-39.0
1 5/8"-8					5I8WTM...028/047	2	22.23	7	TMC25-5	32.4-39.0
1 5/8"-6					5I6WTM...028/049	2	21.17	5	TMC25-5	32.6-38.5
1 3/4"-7					5I7WTM...028/048	2	21.77	6	TMC25-5	39.8-42.0
1 7/8"-6					5I6 WTM...028/049	2	21.17	5	TMC32-5	42.2-45.0
1.9-6					5I6 WTM...028/049	2	21.17	5	TMC32-5	42.2-45.0

For toolholder information, see page 280.

Whitworth for BSW only (con't)

External / Internal

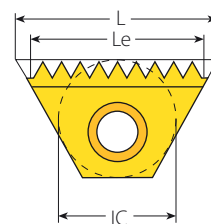
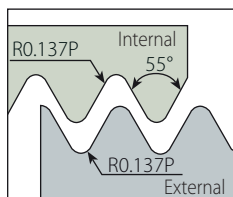

Defined by: B.S.84:1956, DIN259, ISO228/1:1982
Tolerance class: Medium class A

Standard TM

Standard TM Inserts for TMO Toolholders

Insert Size		Pitch	Ordering Code		ECL
IC	L mm	tpi	External + Internal	Toolholder	mm
1/4"	11	28	2EI28WTM2...	TMOC20-2-3	17.24
		26	2EI26WTM2...	TMOC20-2-5	18.56
		24	2EI24WTM2...	TMOC20-2-2	17.99
		20	2EI20WTM2...	TMOC20-2-6	19.05
		19	2EI19WTM2...	TMOC20-2-7	17.38
		14	2EI14WTM2...	TMOC20-2-3	16.33
3/8"	16	26	3EI26WTM2...	TMOC20-3-2	27.35
		26	3EI26WTM2...	TMOC20-3-6	26.38
		24	3EI24WTM2...	TMOC20-3-7	28.57
		20	3EI20WTM2...	TMOC20-3-6	26.67
		19	3EI19WTM2...	TMOC20-3-8	28.07
		18	3EI18WTM2...	TMOC20-3-6	26.81
		16	3EI16WTM2...	TMOC20-3-6	26.99
		14	3EI14WTM2...	TMOC20-3-6	27.21
5/8"	27	12	3EI12WTM2...	TMOC20-3-6	27.52
		11	3EI11WTM2...	TMOC20-3-9	27.71
		16	5EI16WTM2...	TMOC25-5-3	47.63
		14	5EI14WTM2...	TMOC25-5-1	50.80
		14	5EI14WTM2...	TMOC25-5-4	47.17
		12	5EI12WTM2...	TMOC25-5-2	44.45
		11	5EI11WTM2...	TMOC25-5-6	46.18
		10	5EI10WTM2...	TMOC25-5-7	45.72
		9	5EI9WTM2...	TMOC25-5-8	45.16
		8	5EI8WTM2...	TMOC25-5-9	44.45
7	5EI7WTM2...	TMOC25-5-4	43.54		
6	5EI6WTM2...	TMOC25-5-11	42.33		

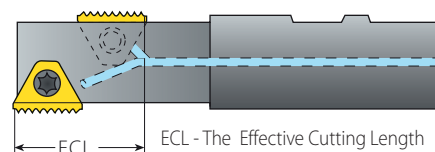

For Le and number of teeth of the above inserts, see the table for standard inserts on page 269.
For toolholder information see page 289.

NPT

External / Internal

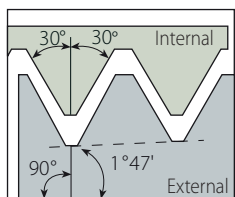

Defined by: USAS B2.1:1968
Tolerance class: Standard NPT

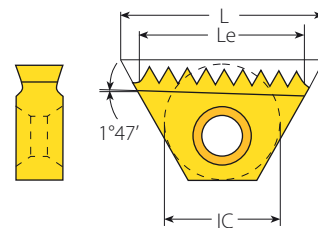

Standard TM

Standard TM

Insert Size		Pitch	Ordering Code	Le	Teeth	Toolholder	
IC	L mm	tpi	External + Internal	mm		RH	LH
3/8"	16	18	3E18NPT-TM2... *	14.11	10		
		14	3E14NPT-TM2...	14.51	8	TMNC...-3	TMNC...-3LH
		11.5	3E11.5NPT-TM2...	13.25	6		
3/8"B	22	14	3BE14NPT-TM2...	21.77	12	BTMNC...-3B	BTMNC...-3BLH
		11.5	3BE11.5NPT-TM2... **	19.88	9		
5/8"	27	11.5	5E11.5NPT-TM2...	24.30	11	TM.C...-5	TM.C...-5LH
		8	5E18NPT-TM2...	22.23	7	TMNC...-5	TMNC...-5LH
3/4"B	38.5	11.5	6BE11.5NPT-TM2...	35.34	16	TMC...-6B	TMC...-6BLH
		8	6BE18NPT-TM2...	31.75	10		

* For external thread only.
To thread with insert cutting edge marked "L", use LH toolholders.
For toolholder information, see page 286.

** Single sided insert - RH only.

TM Standard

NPT

Internal

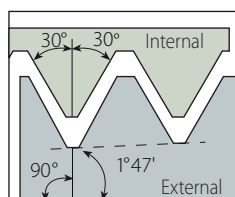

Defined by: USAS B2.1:1968
Tolerance class: Standard NPT

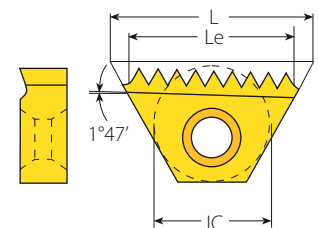

Coarse Pitch TM

Coarse Pitch TM

Thread	Insert Size		Ordering Code	Cutting Edge	Le	Teeth	Toolholder
Inch	IC	L mm	Internal		mm		
1/4"-18	1/4"	11	2I18NPT-TM...028/074	1	9.88	7	TMC20-2-124/009
3/8"-18			2I18NPT-TM...028/074	1	9.88	7	TMC20-2-124/009

For toolholder information, see page 284.

NPTF (Dry Seal)

External / Internal

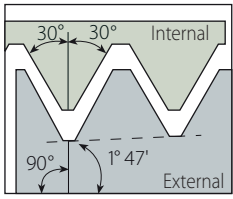

Defined by: ANSI 1.20.3-1976
Tolerance class: Standard NPTF

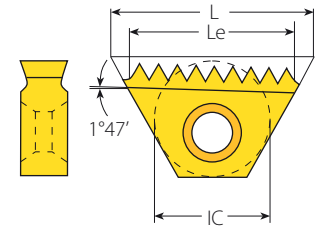

Standard TM

Standard TM

Insert Size		Pitch	Ordering Code	Le	Teeth	Toolholder	
IC	L mm	tpi	External + Internal	mm		RH	LH
3/8"	16	14	3EI14NPTFTM2...	14.51	8	TMNC..-3	TMNC..-3LH
		11.5	3EI11.5NPTFTM2...	13.25	6		
3/8"B	22	14	3BEI14NPTFTM2...	21.77	12	BTMNC..-3B	BTMNC..-3BLH
		11.5	3BEI11.5NPTFTM2...	19.88	9		
5/8"	27	11.5	5EI11.5NPTFTM2...	24.30	11	TMC..-5	TMC..-5LH
		8	5EI8NPTFTM2...	22.23	7		
3/4"B	38.5	11.5	6BEI11.5NPTFTM2...	35.34	16	TMC..-6B	TMC..-6BLH
		8	6BEI8NPTFTM2...	31.75	10		

To thread with insert cutting edge marked "L", use LH toolholders.
For toolholder information, see page 286.

TM Standard

NPTF (Dry Seal)

Internal

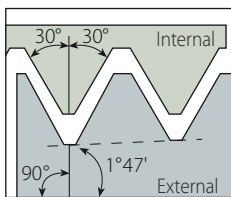

Defined by: ANSI 1.20.3-1976
Tolerance class: Standard NPTF

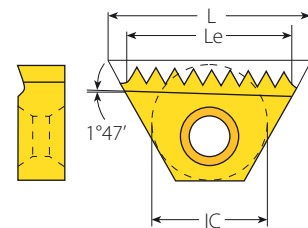

Coarse Pitch TM

Coarse Pitch TM

Thread	Insert Size		Ordering Code	Cutting Edge	Le	Teeth	Toolholder
Inch	IC	L mm	Internal		mm		
1/4"-18	1/4"	11	2I18NPTFTM...028/078	1	9.88	7	TMC20-2-124/009
3/8"-18			2I18NPTFTM...028/078	1	9.88	7	TMC20-2-124/009

For toolholder information, see page 284.

NPS

External / Internal

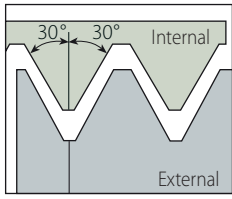

Defined by: USA NBS H28 (1957)
Tolerance class: Standard NPS

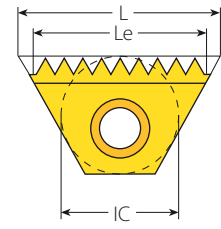

Standard TM

Standard TM

Insert Size		Pitch	Ordering Code	Le	Teeth	Nominal Thread Size	Toolholder
IC	L mm	tpi	External + Internal	mm			
3/8"	16	14	3EI14NPSTM2...	14.51	8	1/2"	TMNC16-3
		14	3EI14NPSTM2...	14.51	8	3/4"	TMNC20-3
		11.5	3EI11.5NPSTM2...	13.25	6	1", 1 1/4"	TMNC20-3
3/8"B	22	11.5	3BEI11.5NPSTM2...*	19.88	9	1", 1 1/4"	BTMNC20-3B
5/8"	27	11.5	5EI11.5NPSTM2...	24.30	11	1 1/2", 2"	TMC25-5
		8	5EI8NPSTM2...	22.23	7	2 1/2" & larger	TMC32-5

* One cutting edge.
All inserts have 2 cutting edges.
For toolholder information, see page 280.

BSPT

External / Internal

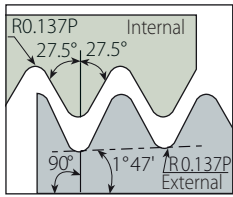

Defined by: B.S. 21:1985
Tolerance class: Standard BSPT

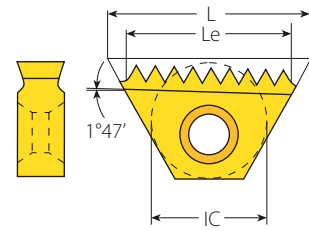

Standard TM

Standard TM

Insert Size		Pitch	Ordering Code	Le	Teeth	Toolholder	
IC	L mm	tpi	External + Internal	mm		RH	LH
1/4"	11	19	2EI19BSPT-TM2...	9.36	7	TMC..-2	TMC..-2LH
3/8"	16	14	3EI14BSPT-TM2...	14.51	8	TMNC..-3	TMNC..-3LH
		11	3EI11BSPT-TM2...	13.85	6		
5/8"	27	11	5EI11BSPT-TM2...	23.09	10	TMC..-5	TMC..-5LH

To thread with insert cutting edge marked "L", use a LH toolholder.
For toolholder information, see page 280.

Pg

External / Internal

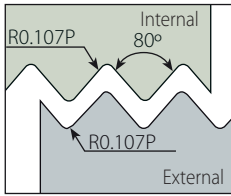

Defined by: DIN 40430
Tolerance class: Standard

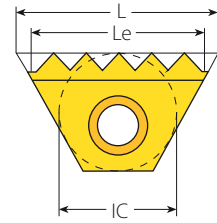

Standard TM

Standard TM

Insert Size		Pitch	Ordering Code	Le	Teeth	Nominal Thread Size	Toolholder
IC	L mm	tpi	External + Internal	mm			
6.0mm	10.4	20	6.0EI20PGTM...	8.99	7	Pg7	TMMC..-6.0
1/4"	11	20	2EI20PGTM2...	10.16	8	Pg7	TMC..-2
		18	2EI18PGTM2...	9.88	7	Pg9, Pg11, Pg13.5, Pg16	TMSH..-2
		16	2EI16PGTM2...	9.53	6	Pg21, Pg29, Pg36, Pg42, Pg48	
3/8"	16	20	3EI20PGTM2...	13.97	11	Pg7	TMC..-3
		18	3EI18PGTM2...	14.11	10	Pg9, Pg11, Pg13.5, Pg16	TMSH..-3
		16	3EI16PGTM2...	14.29	9	Pg21, Pg29, Pg36, Pg42, Pg48	
5/8"	27	16	5EI16PGTM2...	25.40	16	Pg21, Pg29, Pg36, Pg42, Pg48	TMC..-5, TMSH..-5

All inserts have 2 cutting edges, except MiniTM (IC 6.0 mm) which has one edge.
For toolholder information, see page 280.

ACME

Internal

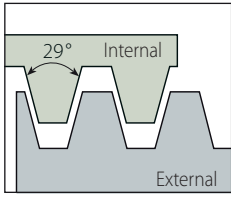

Defined by: ANSI B1/5:1988
Tolerance class: 3G

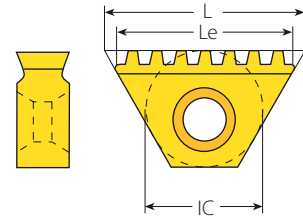

Coarse Pitch TM

Coarse Pitch TM

Thread	Insert Size		Ordering Code	Cutting Edge	Le	Teeth	Toolholder	Bore Dia. Range
Inch	IC	L mm	Internal		mm			mm
1/2"-16	6.0mm	10.4	6.0I16ACMETM...028/052	1	7.94	5	TMMC12-6.0	11.1
1/2"-16			6.0I16ACMETM...028/052	1	7.94	5	TMMC20-6.0	11.1
5/8"-16	1/4"	11	2I16ACMETM...028/053	2	9.53	6	TMC12-2	14.2
5/8"-16			2I16ACMETM...028/053	2	9.53	6	TMC20-2	14.2
5/8"-14			2I14ACMETM...028/054	1	9.07	5	TMC20-2-124/005	14.0
3/4"-16			2I16ACMETM...028/055	2	9.53	6	TMC12-2	17.4
3/4"-16			2I16ACMETM...028/055	2	9.53	6	TMC20-2	17.4
3/4"-14			2I14ACMETM...028/083	1	9.07	5	TMC20-2-124/006	17.2
3/4"-12			2I12ACMETM...028/056	1	8.47	4	TMC20-2-124/006	16.9
7/8"-14			3/8"	16	3I14ACMETM...028/057	2	14.51	8
7/8"-12	1/4"	11	2I12ACMETM...028/058	1	8.47	4	TMC20-2-124/006	20.1
1"-14	3/8"	16	3I14ACMETM...028/059	2	14.51	8	TMC16-3	23.5
1"-12			3I12ACMETM...028/060	2	14.82	7	TMNC16-3	23.2
1"-10	1/2"	22	4I10ACMETM...028/061	1	17.78	7	TMC25-4-124/002	22.8
1"-8			4I8ACMETM...028/062	1	19.05	6	TMC25-4-124/002	22.2
1 1/8"-12	3/8"	16	3I12ACMETM...028/060	2	14.82	7	TMC16-3	26.4
1 1/8"-10	1/2"	22	4I10ACMETM...028/084	1	17.78	7	TMC25-4-124/007	26.0
1 1/8"-8			4I8ACMETM...028/063	1	19.05	6	TMC25-4-124/002	25.4-28.5
1 1/4"-12	3/8"	16	3I12ACMETM...028/060	2	14.82	7	TMC20-3	29.6
1 1/4"-10	5/8"	27	5I10ACMETM...028/064	2	22.86	9	TMC25-5-124/004	29.2
1 1/4"-8	1/2"	22	4I8ACMETM...028/063	1	19.05	6	TMC25-4-124/002	25.4-28.5
1 3/8"-10	5/8"	27	5I10ACMETM...028/065	2	22.86	9	TMC25-5-124/004	32.3
1 3/8"-8			5I8ACMETM...028/066	2	22.23	7	TMC25-5-124/004	31.7
1 3/8"-6			5I6ACMETM...028/067	1	21.17	5	TMC25-5-124/008	30.6
1 1/2"-10			5I10ACMETM...028/068	2	22.86	9	TMC25-5	35.5
1 1/2"-8			5I8ACMETM...028/069	2	22.23	7	TMC25-5-124/004	34.9
1 1/2"-6			5I6ACMETM...028/070	2	21.17	5	TMC25-5-124/004	33.8
1 3/4"-10			5I10ACMETM...028/064	2	22.86	9	TMC32-5	41.9
1 3/4"-8			5I8ACMETM...028/069	2	22.23	7	TMC25-5	41.2
1 3/4"-6			5I6ACMETM...028/070	2	21.17	5	TMC25-5	40.2
1 3/4"-5			5I5ACMETM...028/071	2	20.32	4	TMC25-5-124/004	39.3
2"-8			5I8ACMETM...028/069	2	22.23	7	TMC32-5	47.6
2"-6			5I6ACMETM...028/072	2	21.17	5	TMC25-5	46.5
2"-5			5I5ACMETM...028/071	2	20.32	4	TMC25-5	45.7
2 1/4"-6			5I6ACMETM...028/072	2	21.17	5	TMC32-5	52.9
2 1/4"-5			5I5ACMETM...028/073	2	20.32	4	TMC25-5	52.0
2 1/2"-5			5I5ACMETM...028/073	2	20.32	4	TMC32-5	58.4

For toolholder information, see page 280.

Trapez

Internal

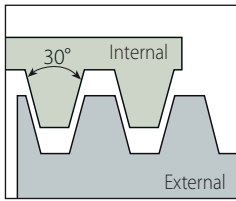

Defined by: Trapez DIN 103
Tolerance class: 7e/7H

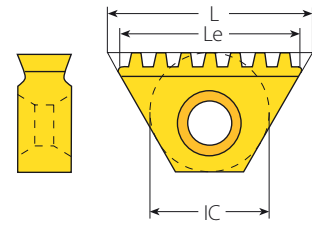
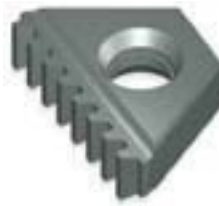

Coarse Pitch TM

Coarse Pitch TM

Thread	Insert Size		Ordering Code	Cutting Edge	Le	Teeth	Toolholder	Bore Dia. Range
mm	IC	L mm	Internal		mm			mm
TR 16X2.0	1/4"	11	212.0TRTM...028/028	1	10	5	TMC20-2-124/006	14.0
TR 18X2.0			212.0TRTM...028/029	1	10	5	TMC20-2-124/006	16.0-18.0
TR 20X2.0			212.0TRTM...028/029	1	10	5	TMC20-2-124/006	16.0-18.0
TR 24X3.0	1/2"	22	413.0TRTM...028/030	1	18	6	TMC25-4-124/002	21.0
TR 26X3.0			413.0TRTM...028/031	1	18	6	TMC25-4-124/002	23.0-27.0
TR 28X3.0			413.0TRTM...028/031	1	18	6	TMC25-4-124/002	23.0-27.0
TR 30X3.0			413.0TRTM...028/031	1	18	6	TMC25-4-124/002	23.0-27.0
TR 32X3.0			413.0TRTM...028/032	1	18	6	TMC25-4-124/007	29.0-33.0
TR 34X3.0			413.0TRTM...028/032	1	18	6	TMC25-4-124/007	29.0-33.0
TR 36X3.0	5/8"	27	413.0TRTM...028/032	1	18	6	TMC25-4-124/007	29.0-33.0
TR 38X3.0			513.0TRTM...028/033	2	24	8	TMC25-5-124/004	35.0-39.0
TR 40X3.0			513.0TRTM...028/033	2	24	8	TMC25-5-124/004	35.0-39.0
TR 42X3.0			513.0TRTM...028/033	2	24	8	TMC25-5-124/004	35.0-39.0
TR 44X3.0			513.0TRTM...028/033	2	24	8	TMC25-5	41.0-45.0
TR 46X3.0			513.0TRTM...028/033	2	24	8	TMC25-5	41.0-45.0
TR 48X3.0			513.0TRTM...028/033	2	24	8	TMC25-5	41.0-45.0
TR 50X3.0			513.0TRTM...028/033	2	24	8	TMC32-5	47.0-57.0
TR 52X3.0			513.0TRTM...028/033	2	24	8	TMC32-5	47.0-57.0
TR 55X3.0			513.0TRTM...028/033	2	24	8	TMC32-5	47.0-57.0
TR 60X3.0			513.0TRTM...028/033	2	24	8	TMC32-5	47.0-57.0
TR 65X4.0			514.0TRTM...028/034	2	24	6	TMC32-5	61.0-106.0
TR 70X4.0			514.0TRTM...028/034	2	24	6	TMC32-5	61.0-106.0
TR 75X4.0			514.0TRTM...028/034	2	24	6	TMC32-5	61.0-106.0
TR 80X4.0			514.0TRTM...028/034	2	24	6	TMC32-5	61.0-106.0
TR 85X4.0			514.0TRTM...028/034	2	24	6	TMC32-5	61.0-106.0
TR 90X4.0			514.0TRTM...028/034	2	24	6	TMC32-5	61.0-106.0
TR 95X4.0			514.0TRTM...028/034	2	24	6	TMC32-5	61.0-106.0
TR 100X4.0	514.0TRTM...028/034	2	24	6	TMC32-5	61.0-106.0		
TR 105X4.0	514.0TRTM...028/034	2	24	6	TMC32-5	61.0-106.0		
TR 110X4.0	514.0TRTM...028/034	2	24	6	TMC32-5	61.0-106.0		

External and Internal Toolholders

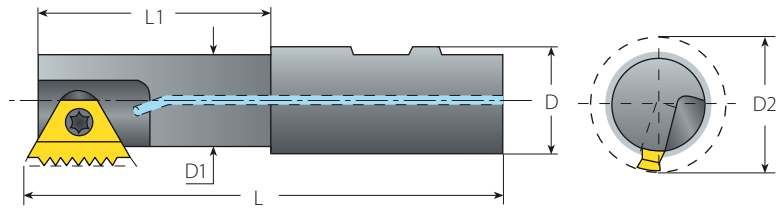
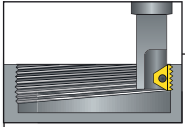

TM Standard

Spare Parts

Insert Size	Ordering Code	Dimensions mm					Spare Parts	
		L	L1	D	D1	D2	Insert Screw	Torx Key
6.0mm	TMMC12-6.0	69.0	12.0	12	6.8	9.0	SN7T	K7T
	TMMC20-6.0	84.0	17.0	20	6.8	9.0		
1/4"	TMC12-2	70.0	12.0	12	8.9	11.5	SN2TM	K2T
	TMC20-2	85.0	20.0	20	8.9	11.5		
	TMC20-2LH	85.0	20.0	20	8.9	11.5		
3/8"	TMC16-3	90.0	22.0	16	13.6	17.0	SN3TM	K3T
	TMC20-3	95.0	43.0	20	16.6	20.0		
3/8"B	BTMC16-3B	79.5	29.0	16	13.5	17.0	SN3T	K3T
	BTMC20-3B	81.5	29.0	20	15.5	19.0		
	BTMC25-3B	92.3	30.0	25	15.5	19.0		
	BTMWC25-3B	90.8	30.0	25	18.5	22.0		
5/8"	TMC25-5	110.0	52.0	25	24.0	30.0	SN5TM	K5T
	TMC25-5LH	110.0	52.0	25	24.0	30.0		
	TMC32-5	120.0	58.0	32	31.0	37.0		
3/4"B	TMC32-6B	115.0	53.0	32	27.0	35.0	SM7T	K30T
	TMC40-6B	135.0	63.0	40	38.0	46.0		

Internal Thread Application for Standard Toolholder

Toolholder		Min. Thread Dia.				
	D2	ISO Coarse	ISO Fine	UNC	UN/UNF/UNEF/UNS	UNJ
TMMC12-6.0 TMMC20-6.0	9.0		M10x0.75; M12x1.0; M14x1.25; M14x1.5		7/16-32UN; 7/16-28UNEF; 1/2-24UNS; 7/16-20UNF; 7/16-18UNF; 9/16-16UNF	9/16-24UNJEF; 1/2-20UNJF; 9/16-18UNJF; 9/16-16UNJF
TMC12-2 TMC20-2 TMC20-2LH	11.5		M15x1.0; M16x1.5		9/16-32UN; 9/16-28UN; 9/16-24UNEF; 5/8-20UN; 9/16-18UNF; 9/16-16UNF; 7/8-14UNF	9/16-24UNJEF; 3/4-20UNJEF; 5/8-18UNJF; 5/8-16UNJF; 7/8-14UNJF
TMC16-3	17.0		M20x1.0; M22x1.5; M24x2.0		3/4-32UN; 13/16-28UN; 7/8-24UNS; 7/8-20UNEF; 7/8-18UNS 7/8-16UNS; 1-14UNS; 13/16-12UN	15/8-24UNJ; 7/8-20UNJEF; 11/16-18UNJEF; 7/8-16UNJ; 15/8-14UNJ; 15/16-12UNJ
TMC20-3	20.0		M24x1.0; M25x1.5; M27x2.0		7/8-32UN; 15/16-28UN; 1-24UNS; 15/16-20UNEF; 1-18UNS; 1-16 UNS; 11/8-14UNS; 11/16-12UN	15/8-24 UNJ; 15/16-20UNJEF; 11/16-18UNJEF; 1-16UNJ; 15/8-14UNJ; 11/16-12UNJ
BTMC16-3B	17.0		M20x1.0; M22x1.5; M24x2.0		7/8-24UNS; 7/8-20UNEF; 7/8-18UNS; 7/8-16UNS; 1-14UNS; 13/16-12UN	
BTMC20-3B BTMC25-3B	19.0		M22x1.0; M24x1.5; M25x2.0		7/8-24UNS; 15/16-20UNEF; 1-18UNS; 1-16UNS; 1-14UNS; 1-12UNF	
BTMWC25-3B	22.0	M27x1.5	M25x1.0; M30x2		1-24UNS; 11/16-20UN; 11/16-18UNEF; 11/16-16UNEF; 11/8-14UNS; 11/8-12UNF	
TMC25-5 TMC25-5LH	30.0		M35x1.5; M39x2.0; M36x3.0; M36x4.0; M42x4.5; M48x5.0	13/4-5	13/8-24UNS; 13/8-20UN; 17/16-18UNEF; 17/16-16UNEF; 11/2-14UNS; 11/2-12UNF; 15/8-10UNS; 17/16-8UN; 15/8-6UN	17/16-16UNJ; 11/2-12UNJF
TMC32-5	37.0		M45x1.5; M45x2.0; M50x3.0; M56x4.0		15/8-24UNS; 111/16-20UN; 111/16-18UNEF; 111/16-16UNEF; 13/4-14UNS; 13/4-12 UN; 17/8-10UNS; 2-8 UN; 21/4-6UN	111/16-16UNJ; 13/4-12UNJ
TMC32-6B	35.0	M64x6.0	M42x1.5; M42x2.0; M48x3.0; M55x4.0; M48x5.0; M56x5.5	2-4.5; 21/2-4	21/4-6UN	
TMC40-6B	46.0	M64x6.0	M52x1.5; M55x2.0; M60x3.0; M60x4.0; M60x5.5	21/2-4	23/8-6UN	

TM Standard

	D2	BSW/BSF	BSP	BSPT	NPT	NPTF	PG	NPS	Trapez	ACME
TMMC12-6.0 TMMC20-6.0	9.0	7/16-26BSF; 1/2-20BSW; 7/16-18BSF;	1/4-19				PG7			1/2-16
TMC12-2 TMC20-2 TMC20-2LH	11.5	5/8-26BSF; 5/8-20BSW; 9/16-16BSF; 11/16-14BSF	3/8-19; 1/2-14	3/8-19			PG9; PG21			5/8-16;
TMC16-3	17.0	13/16-26BSF; 7/8-20BSW; 7/8-16BSW; 13/16-12BSW	5/8-14; 11/4-11				PG13.5; PG21	1/2-14; 1-11.5		1-14; 11/8-12
TMC20-3	20.0	15/16-26BSF; 1-20BSW; 111/16-16BSW; 15/16-12BSW;	3/4-14; 1-11				PG16; PG21	3/4-14; 1-11.5		11/4-12
BTMC16-3B	17.0	7/8-20BSW; 7/8-16BSW; 13/16-12BSW	5/8-14; 1-11					1-11.5		
BTMC20-3B BTMC25-3B	19.0	15/16-20BSW; 1-16BSW; 11/16-12BSW	3/4-14; 1-11					1-11.5		
BTMWC25-3B	22.0	11/16-20BSW; 11/8-16BSW	7/8-14; 1-11					1-11.5		
TMC25-5 TMC25-5LH	30.0	1.4-16BSW; 13/8-12BSW; 17/16-8BSW; 13/4-7BSF; 1.6-6BSW	11/8-11	11/4-11	11/4-11.5	11/4-11.5	PG29	11/4-11.5; 21/2-8	TR44-3.0	11/2-10; 13/4-8; 13/4-6; 2-5
TMC32-5	37.0	13/4-16BSW; 17/8-12BSW; 2.1-8BSW; 17/8-6BSW;	11/2-11	11/2-11	11/2-11.5	11/2-11.5	PG36	11/2-11.5; 21/2-8	TR50-3.0; TR65-4.0	13/4-10; 2-8; 21/4-6; 21/2-5
TMC32-6B	35.0	21/4-6 BSF; 3-5BSF; 31/2-4.5BSF;	11/2-11		21/2-8	21/2-8				
TMC40-6B	46.0	25/8-6BSW; 3-5BSF; 31/2-4.5BSF	2-11		3-8	3-8				

External and Internal Toolholders

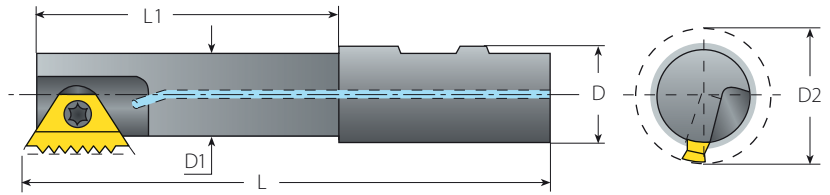
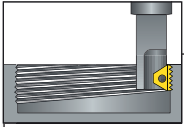

TML Long Tools

Spare Parts

Insert Size	Ordering Code	Dimensions mm					Spare Parts	
		L	L1	D	D1	D2	Insert Screw	Torx Key
1/4"	TMLC25-2	125.0	17.0	25	8.9	11.5	SN2TM	K2T
3/8"	TMLC25-3	125.0	25.0	25	18.6	22.0	SN3T	K3T
	BTMLC25-3	125.0	63.5	25	18.6	22.0		
3/8"B	BTMLC20-3B	96.5	44.0	20	15.5	19.0	SN3T	K3T
	BTMLC25-3B	125.0	63.5	25	18.6	22.0		
5/8"	TMLC25-5	150.0	92.0	25	24.0	30.0	SN5TM	K5T
	TMLC32-5	160.0	98.0	32	31.0	37.0		
3/4"B	TMLC40-6B	165.0	93.0	40	38.0	46.0	SM7T	K30T

Internal Thread Application for TML Toolholder

Toolholder		Min. Thread Dia.				
	D2	ISO Coarse	ISO Fine	UNC	UN/UNF/UNEF/UNS	UNJ
TMLC25-2	11.5		M15x1.0; M16x1.5		9/16-32UN; 9/16-28UN; 9/16-24UNEF; 5/8-20UN; 9/16-18UNF; 9/16-16UNF; 7/8-14UNF	9/16-24UNJEF; 3/4-20UNJEF; 5/8-18UNJF; 5/8-16UNJF; 7/8-14UNJF
TMLC25-3 BTMLC25-3	22.0	M27x1.5	M25x1.0; M30x2.0		1-32UN; 1-28UN; 1-24UNS; 1 1/16-20UN; 1 1/16-18UNEF; 1 1/16-16UNEF; 1 1/8-14UNS; 1 1/8-12	1 5/8-24 UNJ; 1 1/16-20UNJ; 1 1/16-18UNJEF; 1 1/16-16; 1 1/8-12UNJF
BTMLC20-3B	19.0		M22x1.0; M24x1.5; M25x2.0		7/8-24UNS; 15/16-20UNEF; 1-18UNS; 1-16UNS; 1-14UNS; 1-12UNF	
BTMLC25-3B	22.0	M27x1.5	M25x1.0; M30x2.0		1-24UNS; 1 1/16-20UN; 1 1/16-18UNEF; 1 1/16-16UNEF; 1 1/8-14UNS; 1 1/8-12UNF	
TMLC25-5	30.0		M35x1.5; M39x2.0; M36x3.0; M36x4.0; M42x4.5; M48x5.0	1 3/4-5	1 3/8-24UNS; 1 3/8-20UN; 1 7/16-18UNEF; 1 7/16-16UNEF; 1 1/2-14UNS; 1 1/2-12UNF; 1 5/8-10UNS; 1 7/16-8UN; 1 5/8-6UN	1 7/16-16UNJ; 1 1/2-12UNJF
TMLC32-5	37.0		M45x1.5; M45x2.0; M50x3.0; M56x4.0		1 5/8-24UNS; 1 11/16-20UN; 1 11/16-18UNEF; 1 11/16-16UNEF; 1 3/4-14UNS; 1 3/4-12UN; 1 7/8-10UNS; 2-8 UN; 2 1/4-6UN	1 11/16-16UNJ; 1 3/4-12UNJ
TMLC40-6B	46.0	M64x6.0	M52x1.5; M55x2.0; M60x3.0; M60x4.0; M60x5.5	2 1/2-4	2 3/8-6UN	

	D2	BSW/BSF	BSP	BSPT	NPT	NPTF	PG	NPS	Trapez	ACME
TMLC25-2	11.5	5/8-26BSF; 5/8-20BSW; 1 1/16-14BSF	3/8-19; 1/2-14	3/8-19			PG9; PG21			
TMLC25-3 BTMLC25-3	22.0	1 1/16-26BSF; 1 1/16-20BSW; 1 1/8-16BSW	7/8-14; 1-11				PG21	1-11.5		
BTMLC20-3B	19.0	15/16-20BSW; 1-16BSW; 1 1/16-12BSW	3/4-14; 1-11					1-11.5		
BTMLC25-3B	22.0	1 1/16-20BSW; 1 1/8-16BSW	7/8-14; 1-11				PG21	1-11.5		
TMLC25-5	30.0	1 3/4-7BSF; 1 7/8-6BSW	1 1/4-11	1 1/4-11	1 1/4-11.5	1 1/4-11.5	PG29	1 1/4-11.5; 2 1/2-8	TR44-3.0	1 1/2-10; 1 3/4-8; 1 3/4-6; 2-5
TMLC32-5	37.0	1 7/8-6BSW	1 1/2-11	1 1/2-11	1 1/2-11.5	1 1/2-11.5	PG36	1 1/2-11.5; 2 1/2-8	TR50-3.0; TR65-4.0	1 3/4-10; 2-8; 2 1/4-6; 2 1/2-5
TMLC40-6B	46.0	3-5BSF; 3 1/2-4.5BSF	2-11		2 1/2-8	2 1/2-8				

External and Internal Toolholders

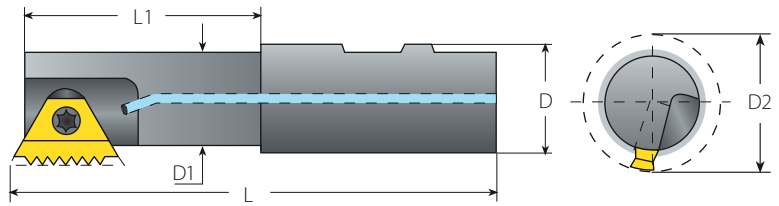

124/... - For Coarse Pitch Threads

Spare Parts

Insert Size	Ordering Code	Dimensions mm					Spare Parts	
		L	L1	D	D1	D2	Insert Screw	Torx Key
6.0mm	TMMC20-6.0-124/003	85	15.0	20	6.7	9.0	SN7T	K7T
1/4"	TMC20-2-124/005	77	15.5	20	7.4	10.0	SN2TM	K2T
	TMC20-2-124/006	77	15.5	20	9.0	12.0		
	TMC20-2-124/009	77	15.5	20	7.4	10.0		
3/8"	TMC16-3-124/001	91	20.5	16	12.2	15.5	SN3TM	K3T
1/2"	TMC25-4-124/002	88	30.0	25	13.4	18.0	SN4TM	K4T
	TMC25-4-124/007	98	40.0	25	16.0	20.0	SA4TM	
5/8"	TMC25-5-124/004	98	40.0	25	19.0	25.0	SA5TM	K5T
	TMC25-5-124/008	98	40.0	25	16.4	22.0	SN5TM	

Internal Thread Application for 124/... Coarse Pitch Toolholder

Toolholder		Min. Thread Dia.				
	D2	ISO Coarse	ISO Fine	UNC	UN/UNF/UNEF/UNS	UNJ
TMMC20-6.0-124/003	9.0	M12x1.75	M12x1.0; M22x1.5; M12x1.75	7/16-14	11/16-32UN; 1/2-24UNS; 9/16-18UNF; 9/16-16UNF	9/16-24UNJEF; 1/2-20UNJF; 9/16-18UNJF; 9/16-16UNJF
TMC20-2-124/005	10.0			1/2-13	5/8-12UN	
TMC20-2-124/006	12.0			5/8-11		
TMC20-2-124/009	10.0					
TMC16-3-124/001	15.5	M20x2.5	M20x1.0; M22x1.5; M22x2.0	3/4-10	11/16-32UN; 3/4-28UN; 3/4-24UNS; 13/16-20UNEF; 7/8-18UNS; 7/8-16UNS; 7/8-14UNF; 7/8-12UN	15/8-24UNJ; 13/16-20UNJEF; 11/16-18UNJEF; 13/16-16UNJ; 7/8-14UNJF; 7/8-12UNJ
TMC25-4-124/002	18.0	M22x2.5; M24x3.0		7/8-9; 1 1/8-7		
TMC25-4-124/007	20.0			1-8		
TMC25-5-124/004	25.0	M30x3.5	M30x1.5; M33x2.0; M39x3.0; M56x4.0	1 3/8-6	1 1/8-24UNS; 1 3/16-20UN; 1 3/16-18UNEF; 1 3/16-16UNEF; 1 1/4-14UNS; 1 1/4-12UNF; 1 1/2-10UNS; 1 1/4-8UN	1 3/16-16UNJ; 1 1/4-12UNJF
TMC25-5-124/008	22.0					

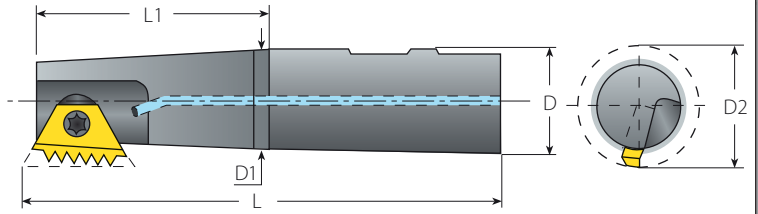
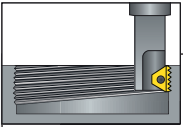

	D2	BSW/BSF	BSP	BSPT	NPT	NPTF	PG	NPS	Trapez	ACME
TMMC20-6.0-124/003	9.0	7/16-26BSF; 7/16-18BSF;	1/4-19				PG7	1/2-14; 1-11.5		
TMC20-2-124/005	10.0	1/2-16BSF								5/8-14
TMC20-2-124/006	12.0	5/8-14BSF							TR16-2	3/4-14; 3/4-12
TMC20-2-124/009	10.0				1/4-18	1/4-18				
TMC16-3-124/001	15.5	3/4-12BSF	1/2-14	3/4-14; 1-11	3/4-14; 1-11.5	3/4-14; 1-11.5	PG13.5; PG21	1-11.5		
TMC25-4-124/002	18.0	7/8-11BSF; 1-10BSF; 7/8-9BSW; 1-8BSW							TR24-3.0	1-10; 1-8
TMC25-4-124/007	20.0								TR32-3.0	1 1/8-10
TMC25-5-124/004	25.0	1 3/16-8BSW; 1 1/4-7BSW; 1 3/16-6BSW	1-11	1-11	1 1/4-11.5; 2 1/2-8	1 1/4-11.5; 2 1/2-8	PG21	1 1/4-11.5; 2 1/2-8	TR38-3.0	1 1/4-10; 1 3/8-8; 1 1/2-6; 1 3/4-5
TMC25-5-124/008	22.0	1 1/8-7BSW								1 3/8-6

External and Internal Toolholders



TMN - For Conical Threads (NPT, NPTF, BSPT)

Spare Parts

Insert Size		Ordering Code		Dimensions mm					
IC	RH	*LH	L	L1	D	D1	D2	Insert Screw	Torx Key
3/8"	TMNC16-3	TMNC16-3 LH	90.0	22.0	16	12.5	15.5	SN3TM	K3T
	TMNC20-3	TMNC20-3 LH	85.0	23.0	20	15.0	19.0		
3/8"B	BTMNC16-3B	BTMNC16-3B LH	79.5	29.0	16	13.5	17.0	SN3TM	K3T
	BTMNC20-3B	BTMNC20-3B LH	81.5	29.0	20	15.5	19.0		
5/8"	TMNC32-5	TMNC32-5 LH	120.0	58.0	32	31.0	37.0	SN5TM	K5T

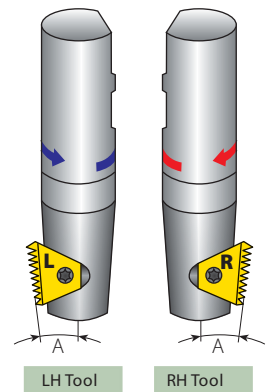

* To use the cutting edge marked "L", LH Cutter is required.

Internal Thread Application for TMN Toolholder

Toolholder		Min. Thread Dia.			
	D2	ISO Fine	UNC	UN/UNF/UNEF/UNS	UNJ
TMNC16-3 TMNC16-3LH	15.5	M20x1.0; M22x1.5; M22x2.0		11/16-32UN; 3/4-28UN; 3/4-24UNS; 13/16-20UNEF; 7/8-18UNS; 7/8-16UNS; 7/8-14UNF; 3/4-12UN	15/8-24UNJ; 13/16-20UNJEF; 11/16-18UNJEF; 13/16-16 UNJ; 7/8-14UNJF; 7/8-12UNJ
TMNC20-3 TMNC20-3LH	19.0	M22x1.0; M24x1.5; M25x2.0		7/8-32UN; 7/8-28UN; 7/8-24UNS; 15/16-20UNEF; 1-18UNS; 1-16UNS; 1-14UNS; 1-12UNF	15/8-24UNJ; 15/16-20UNJEF; 11/16-18UNJEF; 15/16-16UNJ; 1 3/8-14UNJ; 1-12UNJF
BTMNC16-3B BTMNC16-3BLH	17.0	M20x1.0; M22x1.5; M24x2.0		7/8-24UNS; 7/8-20UNEF; 7/8-18UNS; 7/8-16UNS; 1-14UNS; 13/16-12UN	
BTMNC20-3B BTMNC20-3BLH	19.0	M22x1.0; M24x1.5; M25x2.0		7/8-24UNS; 15/16-20UNEF; 1-18UNS; 1-16UNS; 1-14UNS; 1-12UNF	
TMNC32-5 TMNC32-5LH	37.0	M45x1.5; M45x2.0; M50x3.0; M56x4.0		15/8-24UNS; 111/16-20UN; 111/16-18UNEF; 111/16-16UNEF; 13/4-14UNS; 13/4-12UN; 17/8-10UNS; 2-8UN; 21/4-6UN	

	D2	BSW/BSF	BSP	BSPT	NPT	NPTF	PG	NPS	Trapez	ACME
TMNC16-3 TMNC16-3LH	15.5	13/16-16BSW	1/2-14	1/2-14; 1-11	1/2-14; 1-11.5	1/2-14; 1-11.5	PG11; PG21	1/2-14; 1-11.5		7/8-14; 1-12
TMNC20-3 TMNC20-3LH	19.0	15/16-26BSW; 15/16-20BSW; 1-16BSW; 11/16-12BSW	3/4-14; 1-11	3/4-14; 1-11	3/4-14; 1-11.5	3/4-14; 1-11.5	PG21	3/4-14; 1-11.5		
BTMNC16-3B BTMNC16-3BLH	17.0	7/8-20BSW; 7/8-16BSW; 13/16-12BSW	5/8-14; 1-11		3/4-14; 1-11.5	3/4-14; 1-11.5		1-11.5		
BTMNC20-3B BTMNC20-3BLH	19.0	15/16-20BSW; 1-16BSW; 11/16-12BSW	3/4-14; 1-11		3/4-14; 1-11.5	3/4-14; 1-11.5		1-11.5		
TMNC32-5 TMNC32-5LH	37.0	17/8-6BSW	11/2-11	11/2-11	11/2-11.5; 21/2-8	11/2-11.5; 21/2-8	PG36	11/2-11.5; 21/2-8		

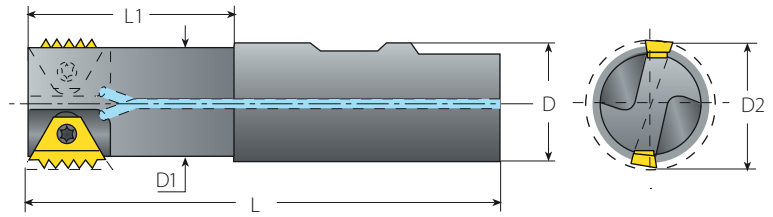
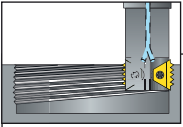

TM Standard

External and Internal Toolholders



TM2 - Twin Flutes

Spare Parts

Insert Size	Ordering Code	Dimensions mm						
IC		L	L1	D	D1	D2	Insert Screw	Torx Key
1/4"	TM2C20-2	85	20.0	20	14.4	17.0	SN2TM	K2T
3/8"	TM2C25-3	100	43.0	25	22.5	26.0	SN3T	K3T
3/8"B	BTM2C25-3B	104.2	46.0	25	22.5	26.0		
5/8"	TM2C32-5	120	45.0	32	36.0	42.0	SN5TM	K5T
3/4"B	TM2C40-6B	137.2	65.0	40	44.0	52.0	SM7T	K30T

TM Standard

Internal Thread Application for TM2 Toolholder

Toolholder	Min. Thread Dia.											
D2 (mm)	ISO Fine	UNC	UN/UNF/UNEF/UNS	UNJ	BSW/BSF	BSP	BSPT	NPT	NPTF	PG	NPS	
TM2C20-2	17.0	M22x1.5		3/4-32UN; 13/16-28UN; 7/8-24UNS; 7/8-20UNEF; 7/8-18UNS; 7/8-16UNS; 1-14UNS	15/8-24UNJ; 7/8-20UNJEF; 11/16-18UNJEF; 7/8-16UNJ; 15/8-14UNJ						PG16; PG21	
TM2C25-3 BTM2C25-3B	26.0	M32x1.5; M33x2.0		1 1/4-24UNS; 1 3/16-20UN; 1 1/4-18UNEF; 1 1/4-16UNEF; 1 3/8-14UNS; 1 5/16-12UN	1 5/8-24UNJ; 1 3/16-20UNJ; 1 1/4-18UNJEF; 1 1/4-16UNJ; 1 5/16-12UNJ	1 3/16-26BSF; 1 1/4-20BSW; 1 5/16-16BSW	1 1/8-11			PG36	1 1/4-11.5	
TM2C32-5	42.0	M48x1.5; M50x2.0; M55x3.0; M64x4.0		1 7/8-20UN; 2-18UNS; 2-16UNS; 2-14UNS; 2-12UN; 2 1/4-10UNS; 2 1/4-8UN; 2 1/2-6UN	1 15/16-16UNJ; 2-12UNJ	2-16BSW; 2-12BSW; 2 1/4-8BSW	2-11	2-11	2-11.5	2-11.5	PG36	2-11.5; 2 1/2-8
TM2C40-6B	52.0	M58x1.5; M68x4.0; M70x6.0	2 3/4-4	2 5/8-6UN		2 7/8-6BSW; 2 7/8-5BSW; 3 3/4-4.5BSF	2 1/4-11		2 1/2-8	2 1/2-8		

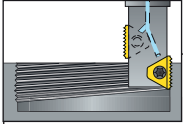

External and Internal Toolholders

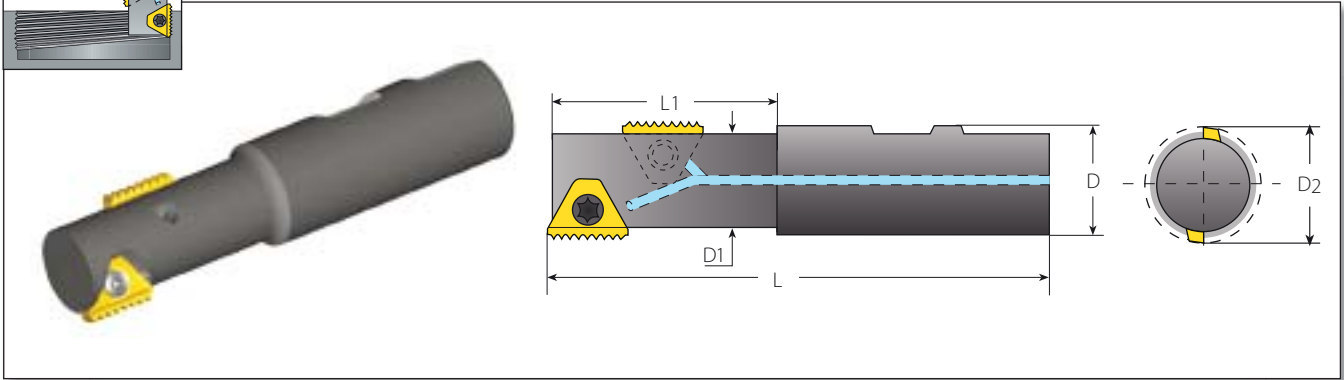

TMO - Twin Flute Offset

Spare Parts

Insert Size	Ordering Code	Applicable Threads			Dimensions mm					Insert Screw	Torx Key
		External	Internal	External & Internal	L	L1	D	D1	D2		
1/4"	TMOC20-2-1	16UN	48/32/16UN		90	25	20	11.9	14.5	SN2TM	K2T
	TMOC20-2-2	24/18UN	48/24/18UN	24W							
	TMOC20-2-3	28/14UN	28/14UN	28/14W							
	TMOC20-2-4	20UN	20UN								
	TMOC20-2-5			26W							
	TMOC20-2-6			20W							
	TMOC20-2-7			19W							
	TMOC20-2-8	1.0/1.5ISO	0.5/1.0/1.5ISO								
	TMOC20-2-9	0.75ISO	48UN, 0.75ISO								
	TMOC20-2-10	1.25ISO	1.25ISO								
3/8"	TMOC20-3-1	1.5ISO	0.5/1.5ISO		95	43	20	16.6	20.0	SN3T	K3T
	TMOC20-3-2	13UN	13UN	26W							
	TMOC20-3-3	28UN	32/28UN								
	TMOC20-3-4	27UN	27UN								
	TMOC20-3-5		11.5UN	11.5NPS							
	TMOC20-3-6	24/20/18/16/14/12UN	24/20/18/16/14/12UN	26/20/18/16/14/12W, 14NPS							
	TMOC20-3-7	1.25ISO	1.25ISO	24W							
	TMOC20-3-8			19W							
	TMOC20-3-9			11W							
	TMOC20-3-10	1.0/2.0ISO	0.5/1.0/2.0ISO								
	TMOC20-3-11	0.75ISO	32UN, 0.75ISO								
	TMOC20-3-12	1.75ISO	1.75ISO								
5/8"	TMOC25-5-1	24/20/18/14/13/12UN	24/20/18/14/13/11UN	14W	110	52	25	24	30.0	SN5TM	K5T
	TMOC25-5-2	24/18/12UN	24/18/12/6UN	12W							
	TMOC25-5-3	16UN	16UN	16W, 8NPS							
	TMOC25-5-4	14/7UN	14UN	14/7W							
	TMOC25-5-5		11.5UN	11.5NPS							
	TMOC25-5-6	11UN	11UN	11W							
	TMOC25-5-7	10UN	10/5UN	10W							
	TMOC25-5-8	9UN	9UN	9W							
	TMOC25-5-9	8UN	8UN	8W							
	TMOC25-5-10		7UN								
	TMOC25-5-11	6UN		6W							
	TMOC25-5-12	1.0/2.0/2.5/4.0ISO	1.0/2.0/2.5/4.0/5.0ISO								
	TMOC25-5-13	1.25ISO	1.25ISO								
	TMOC25-5-14	1.5/2.5/4.5ISO	1.5/2.5/4.5/ISO								
	TMOC25-5-15	1.75ISO	1.75ISO								
	TMOC25-5-16	1.0/1.5/3.0/3.5ISO	1.0/1.5/3.0/3.5ISO								

TM Standard

External and Internal Toolholders

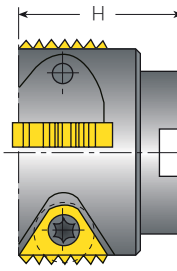
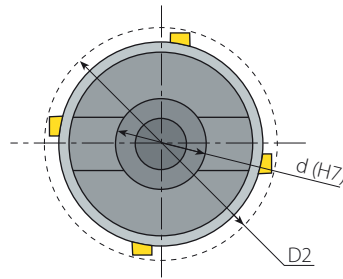
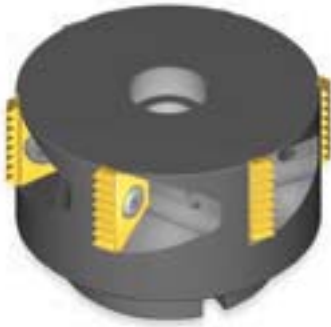
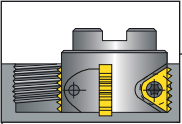

Cutter Drive
ISO 240-1975 (mm)

TM Shell Mill

Spare Parts

Insert Size	Ordering Code	No. of inserts	Dimensions mm					
			D2	d(H7)	H	Insert Screw	Torx Key	Holder Screw
1/4"	TMSH-D38-16-2	6	38.0	16.0	40.0	SN2T	HK2T	M8x1.25x35
1/4"	TMSH-D50-22-2	8	50.0	22.0	40.0			M10x1.50x35
3/8"	TMSH-D50-22-3	6	50.0	22.0	40.0	SN3TM	HK3T	M10x1.50x35
3/8B"	TMSH-D63-22-3B	6	63.0	22.0	40.0			
5/8"	TMSH-D63-22-5	4	63.0	22.0	45.0	SN5TM	HK5T	M10x1.50x35
3/4B"	TMSH-D63-22-6B	4	63.0	22.0	50.0	SM7T	HK7T	M10x1.50x35
5/8"	TMSH-D80-27-5	6	80.0	27.0	50.0	SN5TM	HK5T	M12x1.75x40
3/4B"	TMSH-D80-27-6B	5	80.0	27.0	50.0	SM7T	HK7T	M12x1.75x40
5/8"	TMSH-D100-32-5	7	100.0	32.0	55.0	SN5TM	HK5T	M16x2.00x40
3/4B"	TMSH-D100-32-6B	6	100.0	32.0	55.0	SM7T	HK7T	M16x2.00x40
5/8"	TMSH-D125-40-5	9	125.0	40.0	63.0	SN5TM	HK5T	M20x2.50x50
3/4B"	TMSH-D125-40-6B	8	125.0	40.0	63.0	SM7T	HK7T	M20x2.50x50

Internal Thread Application for Shell Mill Toolholder

Toolholder		Min. Thread Dia.										
	D2 (mm)	ISO Fine	UNC	UN/UNF/UNEF/UNS	UNJ	BSW/BSF	BSP	BSPT	NPT	NPTF	PG	NPS
TMSH-D38-16-2	38.0	M45x1.5		1 ¹¹ / ₁₆ -20UN; 1 ³ / ₄ -18UNS; 1 ³ / ₄ -16UNS; 1 ⁷ / ₈ -14UNS	1 ⁵ / ₈ -24UNJ; 1 ¹¹ / ₁₆ -20UNJ; 1 ³ / ₄ -16UNJ	1 ³ / ₄ -26BSF; 1 ³ / ₄ -20BSW					PG36	
TMSH-D50-22-2	50.0	M56x1.5		2 ¹ / ₄ -20UN; 2 ¹ / ₄ -18UNS; 2 ¹ / ₄ -16UNS; 2 ¹ / ₄ -14UNS	2 ¹ / ₄ -20UNJ; 2 ¹ / ₄ -16UNJ							
TMSH-D50-22-3	50.0	M56x1.5; M58x2.0		2 ¹ / ₄ -20UN; 3 ¹ / ₄ -18UNS; 3 ¹ / ₄ -16UNS; 3 ¹ / ₄ -14UNS; 2 ³ / ₈ -12UN	2 ¹ / ₄ -20UNJ; 2 ¹ / ₄ -16UNJ; 2 ³ / ₈ -12UNJ	2 ¹ / ₄ -20BSW; 2 ³ / ₈ -16BSW; 2 ³ / ₈ -12BSW	2 ¹ / ₄ -11				PG42	2-11.5
TMSH-D63-22-3B	63.0	M70x1.5; M70x2.0		2 ³ / ₄ -20UN; 2 ³ / ₄ -18UNS; 2 ³ / ₄ -16UNS; 2 ³ / ₄ -14UNS; 2 ⁷ / ₈ -12UN			2 ¹ / ₂ -11					
TMSH-D63-22-5	63.0	M70x1.5; M70x2.0; M75x3.0; M80x4.0		2 ³ / ₄ -20UN; 3 ³ / ₄ -18UNS; 3 ³ / ₄ -16UNS; 3 ³ / ₄ -14UNS; 2 ³ / ₄ -16UNJ; 2 ⁷ / ₈ -12UN; 3-8UN	2 ³ / ₄ -16UNJ; 2 ³ / ₄ -12UNJ	2 ⁷ / ₈ -16BSW; 2 ⁷ / ₈ -12BSW; 3 ³ / ₈ -8BSW	2 ¹ / ₂ -11	3-11				3-8
TMSH-D63-22-6B	63.0	M70x2.0; M80x4.0; M85x6.0	3 ¹ / ₄ -4	3 ¹ / ₄ -6UN		3 ³ / ₈ -6BSW; 3 ¹ / ₂ -4.5BSF	2 ¹ / ₂ -11		3-8	3-8		
TMSH-D80-27-5	80.0	M90x2.0; M95x3.0; M95x4.0		3 ¹ / ₂ -18UNS; 3 ¹ / ₂ -16UNS; 3 ¹ / ₂ -14UNS; 3 ¹ / ₂ -12UN; 3 ³ / ₄ -10UNS; 3 ³ / ₄ -8UN	3 ³ / ₈ -16UNJ; 3 ¹ / ₂ -12UNJ	3 ¹ / ₂ -16BSW; 3 ¹ / ₂ -12BSW; 3 ³ / ₄ -8BSW	3 ¹ / ₄ -11	4-11				3 ¹ / ₂ -8
TMSH-D80-27-6B	80.0	M90x2.0; M95x4.0; M105x6.0		3 ⁷ / ₈ -6UN		4-6BSW	3 ¹ / ₄ -11		3 ¹ / ₂ -8	3 ¹ / ₂ -8		
TMSH-D100-32-5	100.0	M110x2.0; M115x3.0; M115x4.0			4 ¹ / ₄ -16UNJ; 4 ³ / ₈ -12UNJ	4 ¹ / ₄ -16BSW; 4 ¹ / ₄ -12BSW; 4 ⁵ / ₈ -8BSW	4-11	4-11				
TMSH-D100-32-6B	100.0	M110x2.0; M115x4.0; M125x6.0				4 ⁷ / ₈ -6BSW	4-11		5-8	5-8		
TMSH-D125-40-5	125.0	M135x2.0; M140x3.0; M140x4.0			5 ¹ / ₄ -16UNJ; 5 ³ / ₈ -12UNJ	5 ¹ / ₄ -16BSW; 5 ¹ / ₄ -12BSW; 5 ⁵ / ₈ -8BSW	5-11	5-11				
TMSH-D125-40-6B	125.0	M135x2.0; M140x4.0; M150x6.0				5 ⁷ / ₈ -6BSW	5-11		5-8	5-8		

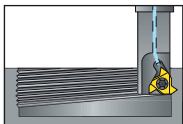

External and Internal Toolholders

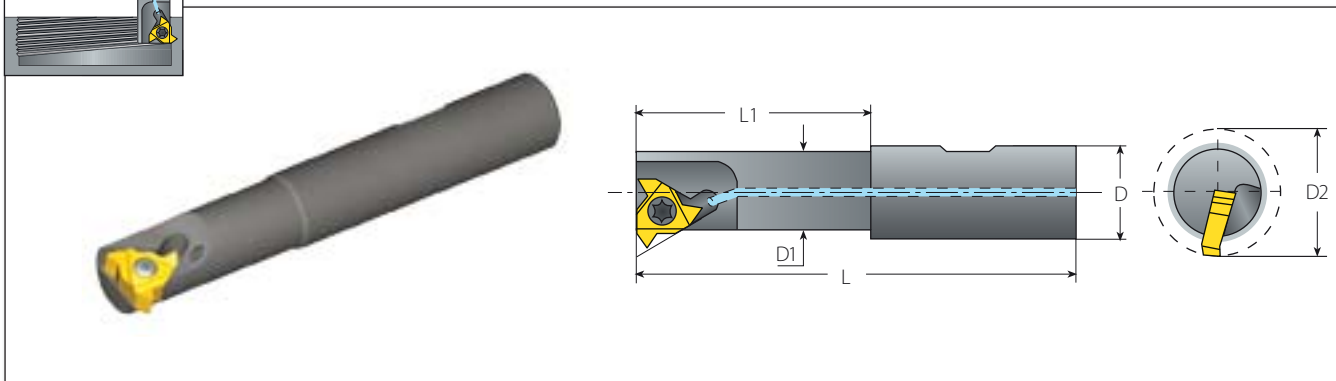

TMS - Single Point (Standard Inserts)

Spare Parts

Insert Size	Ordering Code	Dimensions mm					Spare Parts	
IC		L	L1	D	D1	D2	Insert Screw	Torx Key
1/4"	TMSC10-2	65	25	10	9.3	12.5	SN2TK	K2T

Use Standard laydown thread turning inserts. See Thread Turning Inserts section - Page 17.
Use external LH inserts for external thread and internal RH inserts for internal thread.

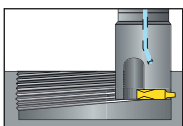

External and Internal Toolholders

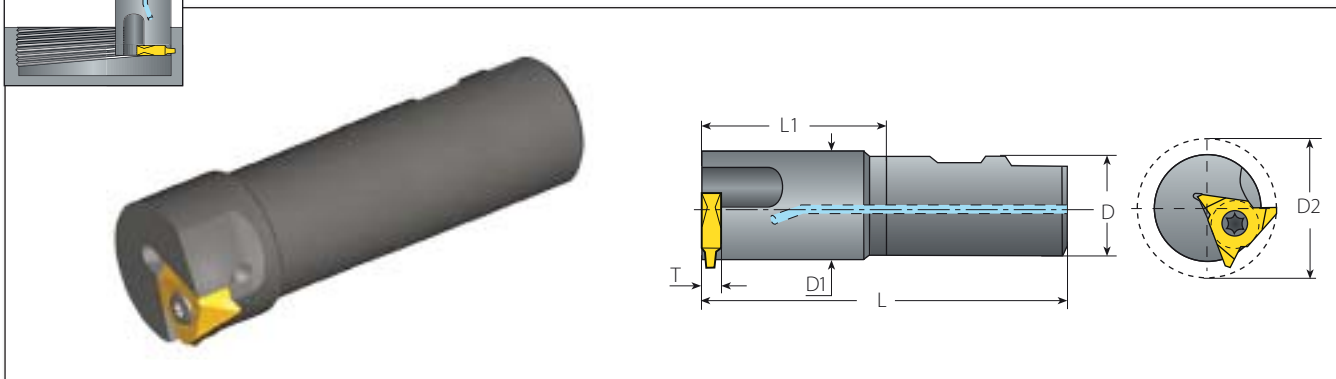

TMV - Single Point (Vertical Insert)

Spare Parts

Insert Size	Ordering Code	Dimensions mm					Spare Parts	
IC		L	L1	D	D1	D2	Insert Screw	Torx Key
5/8"V	TMVC32-5	120	60	32	35.6	46	SN6T	K6T



Requires IC 5/8" Vertical thread turning inserts (width T=6). Use external LH inserts for external threads and internal RH inserts for internal threads.
See Thread Turning Inserts section - Page 17.

Recommended Grades, Cutting Speeds Vc [m/min] and Feed f [mm/tooth]

Material Group	Vargus No.	Material	Hardness Brinell HB	Vc [m/min]			Feed f [mm/tooth]	
				Coated		Uncoated		
				VBX	VTX	VK2		
P Steel	1	Unalloyed Steel	Low Carbon (C=0.1-0.25%)	125	100-210	90-180	0.05-0.3	
	2		Medium Carbon (C=0.25-0.55%)	150	100-180	90-170	0.05-0.25	
	3		High Carbon (C=0.55-0.85%)	170	100-170	90-160	0.05-0.2	
	4	Low Alloy Steel (alloying elements ≤5%)	Non Hardened	180	90-160	90-155	0.05-0.25	
	5		Hardened	275	80-180	80-160	0.05-0.2	
	6		Hardened	350	70-140	70-150	0.05-0.15	
	7	High Alloy Steel (alloying elements >5%)	Annealed	200	60-130	70-115	0.05-0.2	
	8		Hardened	325	70-110	60-100	0.05-0.1	
	9	Cast Steel	Low Alloy (alloying elements <5%)	200	100-170	100-170	100-150	0.05-0.15
	10		High Alloy (alloying elements >5%)	225	70-120	70-130	60-130	0.05-0.1
M Stainless Steel	11	Stainless Steel Ferritic	Non Hardened	200	100-170	120-180	0.05-0.15	
	12		Hardened	330	100-170	120-180	0.05-0.1	
	13	Stainless Steel Austenitic	Austenitic	180	70-140	100-140	0.05-0.15	
	14		Super Austenitic	200	70-140	100-140	0.05-0.1	
	15	Stainless Steel Cast Ferritic	Non Hardened	200	70-140	100-140	0.05-0.15	
	16		Hardened	330	70-140	100-140	0.05-0.1	
	17	Stainless Steel Cast Austenitic	Austenitic	200	70-120	100-120	0.05-0.15	
	18		Hardened	330	70-120	100-120	0.05-0.1	
K Cast Iron	28	Malleable Cast Iron	Ferritic (short chips)	130	60-130	100-120	0.02-0.8	
	29		Pearlitic (long chips)	230	60-120	80-100	0.02-0.05	
	30	Grey Cast Iron	Low Tensile Strength	180	60-130	80-100	0.05-0.15	
	31		High Tensile Strength	260	60-100	80-100	0.05-0.1	
	32	Nodular Sg Iron	Ferritic	160	60-125	80-100	0.05-0.15	
	33		Pearlitic	260	50-90	60-90	0.05-0.1	
N Non-Ferrous Metals	34	Aluminium Alloys Wrought	Non Aging	60	100-250		200-300	0.1-0.4
	35		Aged	100	100-180		60-110	0.1-0.3
	36	Aluminium Alloys	Cast	75	150-400		60-120	0.1-0.3
	37		Cast & Aged	90	150-280		60-100	0.05-0.25
	38	Aluminium Alloys	Cast Si 13-22%	130	80-150		20-50	0.1-0.3
	39	Copper and Copper Alloys	Brass	90	120-210	100-200	50-70	0.1-0.3
	40		Bronze And Non Leaded Copper	100	120-210	100-200	50-70	0.05-0.25
	S Heat Resistant Material	19	High Temperature Alloys	Annealed (iron based)	200	20-45	20-40	20-30
20		Aged (iron based)		280	20-30	20-30	15-25	0.02-0.05
21		Annealed (nickel or cobalt based)		250	20-50	15-20	15-20	0.02-0.05
22		Aged (nickel or cobalt based)		350	10-15	10-15	10-15	0.02-0.05
23		Titanium Alloys	Pure 99.5 Ti	400Rm	70-140	70-120	40-60	0.02-0.05
24			α+β Alloys	1050Rm	20-50	20-50	20-40	0.02-0.05
H Hardened Material	25	Extra Hard Steel	Hardened & Tempered	45-50HRC	20-45	20-45		0.01-0.03
	26			51-55HRC	20-45	20-45		0.01-0.02

TM Standard

Grades

Grade	Application	Sample
VBX	First choice for steel and cast iron A tough sub-micron substrate with TiCN coating	
VTX	First choice for stainless steel A tough sub-micron substrate with TiAlN coating	
VK2	Uncoated grade for machining cast iron & nonferrous metals	



TMSD





Thread Milling for Deep Holes

Inserts | Toolholders

Vardex Ordering Code System

TMSD Inserts

2	U	I	DB	60	TM	VBX
1	2	3	4	5	6	7

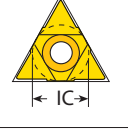
1 - Insert Size	2 - Insert Style	3 - Type of Insert	4 - Pitch			5 - Standard		
5 - IC5.0 mm 2 - IC1/4" 3 - IC3/8" 4 - IC1/2" 5 - IC5/8" 7 - IC6.8 mm 9 - IC8.5 mm 11 - IC10.7 mm	U -  A -  L -  V -  Vertical Style 7, 9, 11 V -  V Style 5/8"	I - Internal EI - External + Internal	Full Profile - Pitch Range			60 - Partial Profile 60° 55 - Partial Profile 55° ISO - ISO Metric UN - American UN NPT - NPT TR - Trapez DIN 103 ACME - ACME STACME - Stub ACME ABUT - American Buttress APIRD - API Round Casing & Tubing		
			mm		tpi			
			1.0-8.0		18-2.5			
			Partial Profile - U, A, L Styles		Partial Profile - Vertical Style			
				mm	tpi			
			DA	0.5-1.5	48-16	VA	0.5-1.0	28-27
			DB	1.5-2.0	16-12	VB	-	11-9
			DC	2.5-4.0	10-6	VC	-	16-10
			DD	2.0-2.5	9-12	VD	1.0-2.0	24-12
			DE	2.5-3.5	10-7	VE	2.0-3.0	12-8
			DH	4.0-6.0	6-4	VF	1.0-1.5	24-16
			DK	6.0-8.0	4-3	VG	1.5-2.0	16-12
			DL	-	11-7	VH	-	16-14
			DM	2.5	10	VK	2.0-2.5	12-10
			DN	1.0-2.0	24-11	VJ	-	26-19
			DP	1.5-3.0	16-8	VM	-	8-7
			DR	-	26-14	VN	1.5-2.5	16-11
			DT	2.0-4.0	12-6			

TMSD Toolholders (U, A, L Styles)

C	TM	2	S	C	14	C	17	-	65	-	2	U
1	2	3	4	5	6	7	8		9		10	11
1 - Shank Style None - Steel C - Carbide Shank	2 - System TM	3 - No. of Flutes 1- 4	4 - Insert Type S - Single Point	5 - Cooling C - Coolant	6 - Shank Dia. 8 - 40	7 - Shank Type W - Weldon C - Cylindrical	8 - Cutting Dia. 13 - 42		9 - Max. Tool Overhang 144	10 - Insert Size 5 - IC5.0 mm 2 - IC1/4" 3 - IC3/8" 4 - IC1/2"	11 - Insert Style U A L	12 - Tool Application ABUT - For American Buttress

TMSD Toolholders (Vertical Style)

C	GM	C	9	C	13	-	45	-	7	-	3
1	2	3	4	5	6		7		8		9
1 - Holder Type None - Steel Shank C - Carbide Shank	2 - System GM- Groove Milling and Thread Milling	3 - Cooling C - Coolant	4 - Shank Dia. 8, 9, 11.5, 12, 14, 15, 20, 25	5 - Shank Style C - Cylindrical W - Weldon	6 - Cutting Dia. 10.5-22.0	7 - Tool Overhang 25-65	8 - Insert Size 7 - IC6.8 mm 9 - IC8.5 mm 11 - IC10.7 mm		9 - Number of Flutes 3		

TMSD Shell Mill (U, L, V Styles)

TM	4	S	C		D42	-	16	-	3	U	
1	2	3	4		5		6		7	8	9
1 - System TM	2 - No. of Flutes 4-7	3 - Insert Type S - Single Point	4 - Cooling C - Coolant	5 - Cutting Dia. 42 - 98	6 - Drive Hole Dia. 16, 22, 27, 32	7 - Insert Size 3 - IC3/8" 4 - IC1/2" 5 - IC5/8"	8 - Insert Style U, L, V		9 - Tool Application ABUT - American Buttress		

TMSD

Thread Milling for Deep Holes

A multi-flute, highly productive and economical solution for milling threads in deep holes



Full Profile Inserts



ISO, American UN, NPT, API RD

American Buttress

U Style For Large Pitches

Weldon Shank



Tool Overhang (L1) 40-145
Cutting Dia. (D2) 14.75-42
No. of Flutes (Z) 1-4

Carbide Cylindrical Shank



Tool Overhang (L1) max 135
Cutting Dia. (D2) 14.75-31.0
No. of Flutes (Z) 1-4

Steel Cylindrical Shank



Tool Overhang (L1) max 144
Cutting Dia. (D2) 23.3-36.5
No. of Flutes (Z) 2-4

Shell Mill



Tool Overhang (L1) max 200
Cutting Dia. (D2) 42-98
No. of Flutes (Z) 4-7

L Style (Mini L) For Small Bores

Weldon Shank



Tool Overhang (L1) 29-42
Cutting Dia. (D2) 13-17.7
No. of Flutes (Z) 1-3

Carbide Cylindrical Shank



Tool Overhang (L1) max 65
Cutting Dia. (D2) 13-17.7
No. of Flutes (Z) 1-3

Vertical Style (7V, 9V, 11V)

Weldon Shank



Tool Overhang (L1) 25-45
Cutting Dia. (D2) 10.5-20.8
No. of Flutes (Z) 3

Carbide Cylindrical Shank



Tool Overhang (L1) max 65
Cutting Dia. (D2) 10.5-20.8
No. of Flutes (Z) 3

L Style (3/8" L) For Large Trapezoid Profiles and ABUT

Weldon Shank



Tool Overhang (L1) 50-105
Cutting Dia. (D2) 21.6-35.5
No. of Flutes (Z) 1-3

Carbide Cylindrical Shank



Tool Overhang (L1) max 120
Cutting Dia. (D2) 21.6-33.5
No. of Flutes (Z) 1-3

Shell Mill



Tool Overhang (L1) max 200
Cutting Dia. (D2) 48-80
No. of Flutes (Z) 5-7

A Style For Shorter L2

Steel Cylindrical Shank



Tool Overhang (L1) max 144
Cutting Dia. (D2) 26-35.3
No. of Flutes (Z) 3

Partial Profile 60°

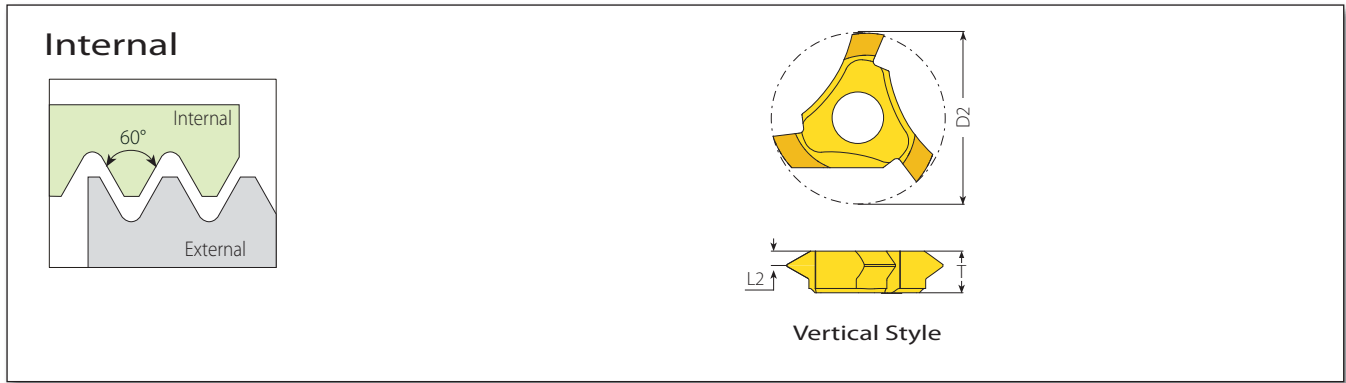

Vertical Style

Insert Style	Pitch		Ordering Code	Dimensions mm				Application (Min. Thread Size)					Toolholder		
	IC	mm		tpi	Internal	D2	T	L2	ISO Coarse	ISO Fine	UNC	UN/UNF/UNEF/UNS			
7V	0.5-1.0	28-27	7VIVA60TM3...	10.5	2.9		0.6	-	M11.5x0.5; M11.5x0.75; M12x1.0	-	1/2-28UNEF; 1/2-27UNS		CGMC8C13-40-7-3 CGMC9C13-45-7-3 GMC20W13-25-7-3		
	1.0-1.5	24-16	7VIVF60TM3...	11.1					0.8		-	M12.5x1; M13x1.5		1/2-24UNS; 1/2-20UNF; 5/16-18UNF; 5/16-16UN	
	1.5-2.0	16-12	7VIVG60TM3...	11.8					1.0		M14x2.0	M14x1.5		5/16-16UN; 5/16-14UNS; 5/8-12UN	
	1.5-2.5	16-11	7VIVN60TM3...	12.4					1.1		-	M15x1.5 M16x2		5/8-11; 5/8-12	5/8-14UNS; 5/16-16UN
9V	0.5-1.0	28-27	9VIVA60TM3...	13.1	4.2		0.6	-	M14x0.5; M14x0.75; M15x1	-	5/16-28UN; 5/16-27UNS		CGMC11.5C17-50-9-3 CGMC12C17-50-9-3 GMC20W17-30-9-3		
	1.0-1.5	24-16	9VIVF60TM3...	13.7					0.8		-	M15x1; M15.5x1.5		5/8-24UNEF; 5/8-20UN; 5/8-18UNF; 5/8-16UN	
	1.5-2.0	16-12	9VIVG60TM3...	14.4					1.0		-	M16.5x1.5; M17x2		11/16-16UN; 3/4-14UNS; 11/16-12UN	
	2.0-2.5	12-10	9VIVK60TM3...	15.1					1.4		-	M17.5x2; M18x2.5		3/4-10	11/16-12UN;
11V	1.0-2.0	24-12	11VVD60TM3...	17.9	5.5		1.0	-	M19x1, M19.5x1.25; M19.5x1.5; M20x1.75; M20x2	-	3/4-24UNS; 13/16-20UNEF; 7/8-18UNS; 13/16-16UN; 7/8-14UNF; 13/16-12UN		CGMC14C22-60-11-3 CGMC15C22-65-11-3 GMC25W22-45-11-3		
	2.0-3.0	12-8	11VIVE60TM3...	19.5					1.5		M22x2.5 M24x3	M23x2		1-8	7/8-10UNS; 7/8-12UN



TMSD

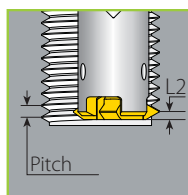

Vertical Style

Partial Profile 55°

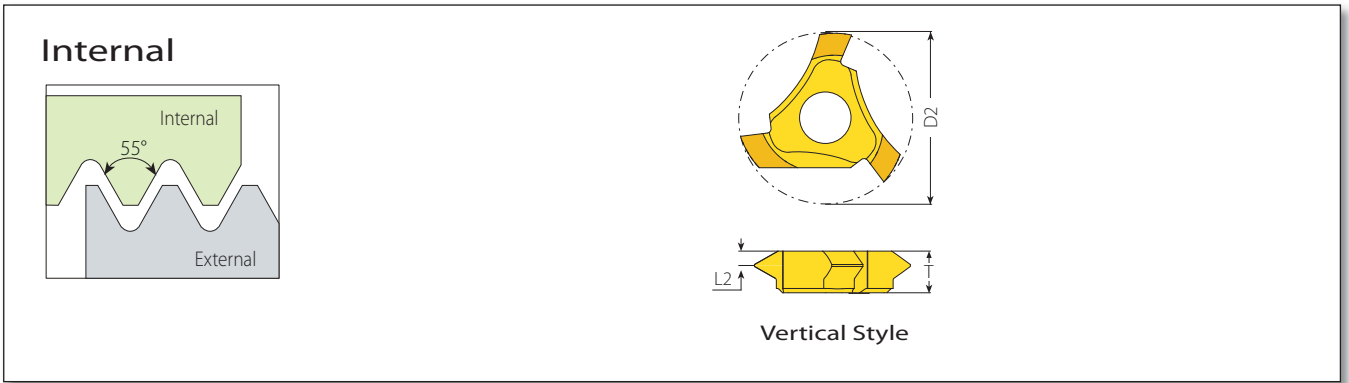

Vertical Style



Insert Style		Ordering Code	Dimensions mm				Application (Min. Thread Size)		
IC	tpi	Internal	D2	T	L2	r	BSP (G)	Partial 55°	Toolholder
7V	26-19	7VIVJ55TM3...	11.35	2.9	0.8	0.07	¼-19; ⅜-19	-	CGMC8C13-40-7-3 CCGMC9C13-45-7-3 GMC20W13-25-7-3
	16-14	7VIVH55TM3...	12.0		1.0	0.13	½-14; ⅝-14; ¾-14; 7/8-14;	⅝-16; ⅝-14	
9V	26-19	9VIVJ55TM3...	13.35	4.2	0.8	0.09	⅜-19	⅝-26; ⅝-16	CGMC11.5C17-50-9-3 CGMC12C17-50-9-3 GMC20W17-30-9-3
	16-10	9VIVC55TM3...	15.4		1.2	0.15	½-14	¾-16; 11/16-14; ¾-12; 7/8-11; ¾-10	
11V	16-12	11VIVG55TM3...	17.8	5.5	0.9	0.16	½-14	1 1/16-16; 1 1/16-12	
	11-9	11VIVB55TM3...	19.1		1.3	0.21	1-11	7/8-11; 1-10; 1 1/8-9	CGMC14C22-60-11-3 CGMC15C22-65-11-3 GMC25W22-45-11-3
	8-7	11VIVM55TM3...	19.6		1.5	0.36	-	1-8; 1 1/8-7;	

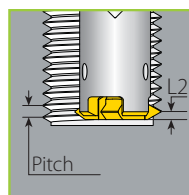

Vertical Style

TMSD

Trapez

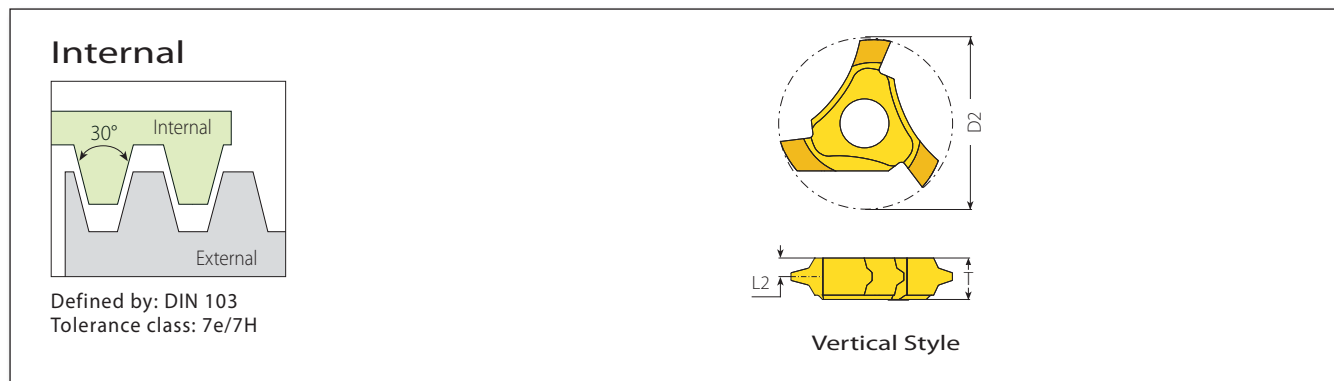

Vertical Style

	Insert Style		Ordering Code	Dimensions mm			Application	
	IC	mm	Internal	D2	T	L2	Trapez	Toolholder
	7V	2.0	7VI2.0TR-1TM3...	12.3	2.9	1.3	TR16x2	CGMC8C13-40-7-3 CGMC9C13-45-7-3 GMC20W13-25-7-3
			7VI2.0TR-2TM3...				TR18x2	
			7VI2.0TR-3TM3...				TR20x2	
	9V	3.0	9VI3.0TR-1TM3...	15.4	4.2	1.95	TR22x3	CGMC11.5C17-50-9-3 CGMC12C17-50-9-3 GMC20W17-30-9-3
			9VI3.0TR-2TM3...				TR24x3	

Stub ACME

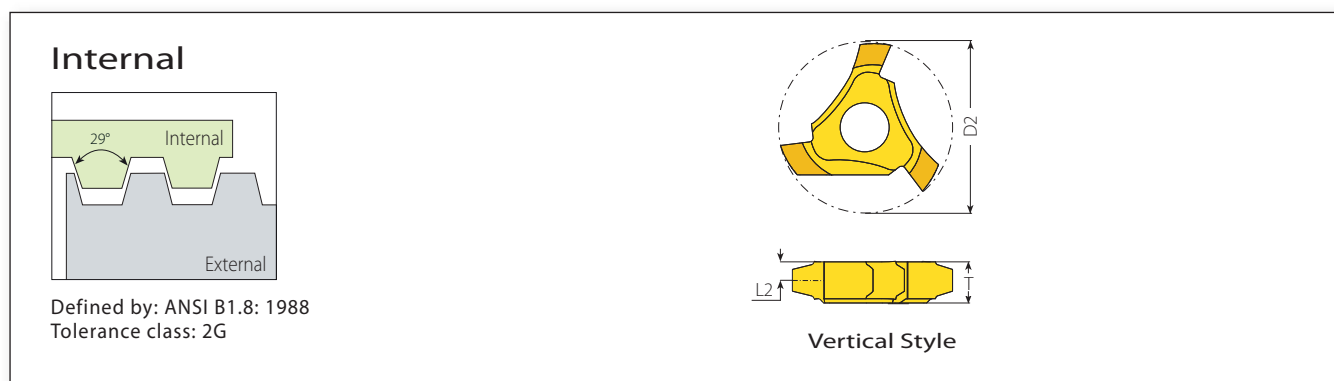

Vertical Style

	Insert Style		Ordering Code	Dimensions mm			Application				
	IC	tpi	Internal	D2	T	L2	Stub ACME	Toolholder			
	7V	8	7VI8STACMETM3...	12.3	2.9	1.3	5/8-8	CGMC8C13-40-7-3 CGMC9C13-45-7-3 GMC20W13-25-7-3			
		6	7VI6STACME-1TM3...				12.7		2.9	1.3	3/4-6
			7VI6STACME-2TM3...								7/8-6
	9V	5	9VI5STACME-1TM3...	16.7	4.2	1.95	1-5	CGMC11.5C17-50-9-3 CGMC12C17-50-9-3 GMC20W17-30-9-3			
			9VI5STACME-2TM3...				1 1/4-5				
			9VI5STACME-3TM3...				1 3/8-4				
	11V	4	11VI4STACME-1TM3...	20.8	5.5	2.6	1 1/2-4	CGMC14C22-60-11-3 CGMC15C22-65-11-3 GMC25W22-45-11-3			
			11VI4STACME-2TM3...				1 3/4-4				
			11VI4STACME-3TM3...				2-4				
			11VI4STACME-4TM3...								

Vertical Toolholders - Weldon Shank

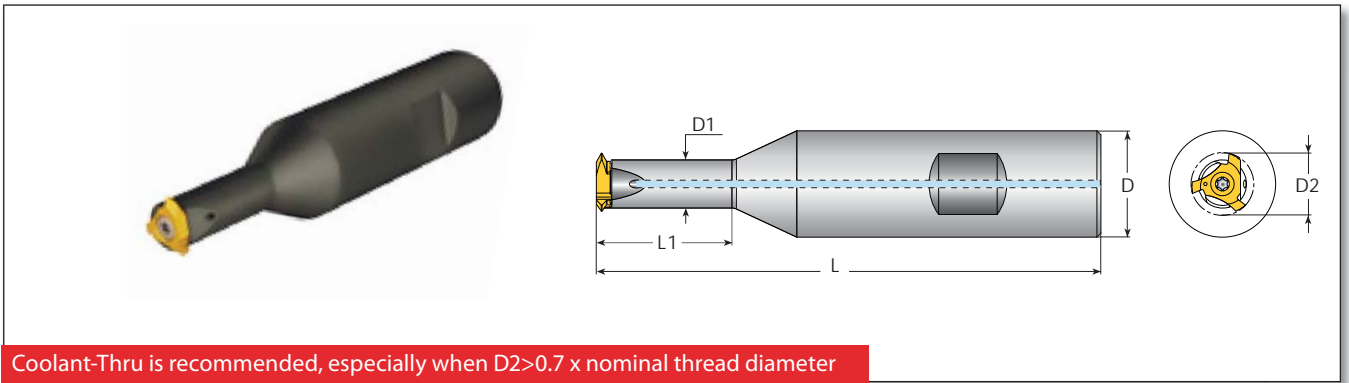

Insert Style	Ordering Code	Dimensions mm					Spare Parts			
		Toolholder	L	L1	D	D1	D2*	Insert Screw	Torx Key	Blade
7V	GMC20W13-25-7-3	95	25	20	9	10.5-12.7	SN2T8-M1 (M3.0x0.5x9)	K2T	-	-
9V	GMC20W17-30-9-3	105	30	20	11.5	13.1-16.7	SN3T15-M2 (M4x0.7x13.5)	-	Blade T15-1/4	Smart Handle 1/4x2
11V	GMC25W22-45-11-3	115	45	25	15	17.8-20.8	SN4T20-M3 (M5x0.8x15.5)	-	Blade T20-1/4	Smart Handle 1/4x2

* The tool cutting diameter (D2) is defined by the insert (See pages 298-300).

TMSD

For Correct Clamping:

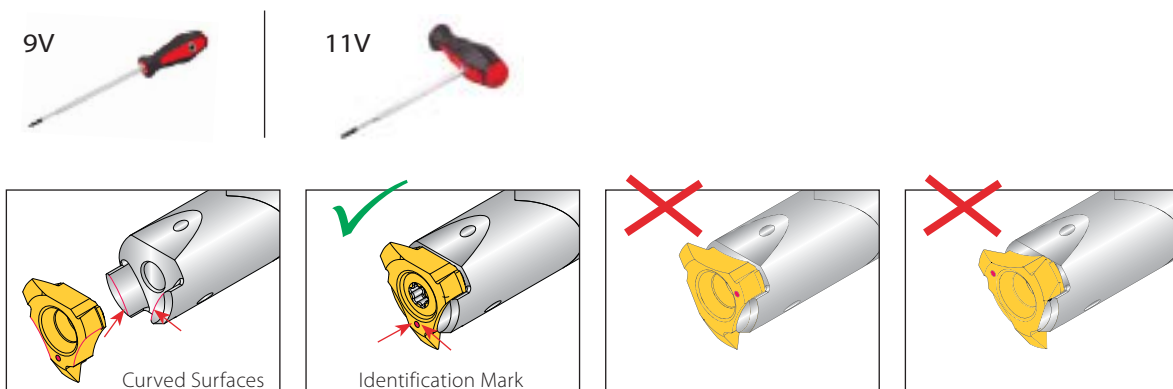

Always mount insert with the identification mark between the two curved surfaces on the toolholder.

Vertical Toolholders - Carbide Cylindrical Shank

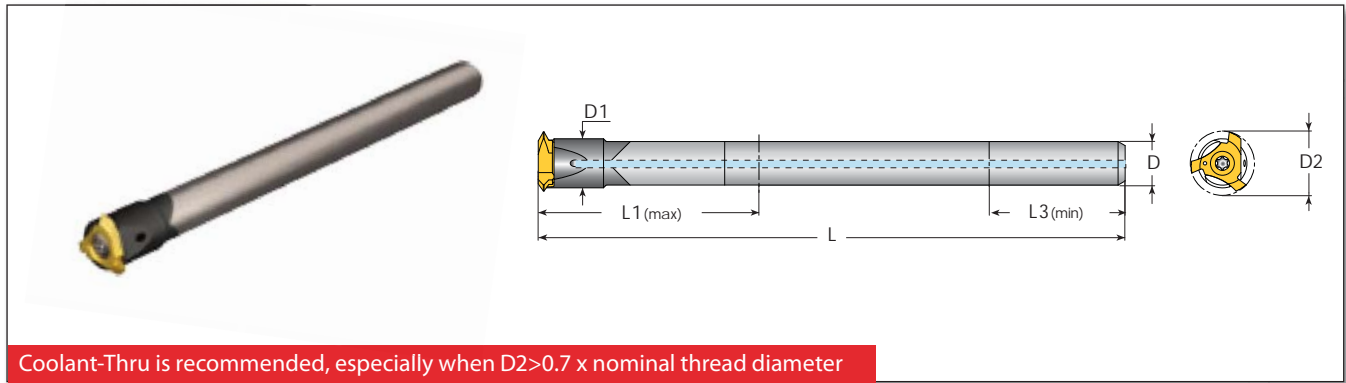

Coolant-Thru is recommended, especially when $D2 > 0.7 \times$ nominal thread diameter

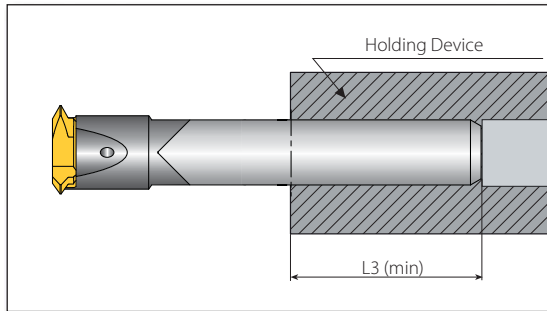

Spare Parts

Insert Style	Ordering Code	Dimensions mm						Spare Parts			
		L	L1	L3 (min)	D	D1	D2*	Insert Screw	Torx Key	Blade	Handle
7V	CGMC8C13-40-7-3	115	40	18	8	9	10.5-12.7	SN2T8-M1 (M3.0x0.5x9)	K2T	-	-
	CGMC9C13-45-7-3		45	20	9						
9V	CGMC11.5C17-50-9-3	125	50	25	11.5	11.5	13.1-16.7	SN3T15-M2 (M4x0.7x13.5)	-	Blade T15-1/4	Smart Handle 1/4x2
	CGMC12C17-50-9-3		50	26	12						
11V	CGMC14C22-60-11-3	135	60	30	14	15	17.8-20.8	SN4T20-M3 (M5x0.8x15.5)	-	Blade T20-1/4	Smart Handle 1/4x2
	CGMC15C22-65-11-3		65	32	15						

* The tool cutting diameter (D2) is defined by the insert (See pages 298-300).

For Correct Clamping:

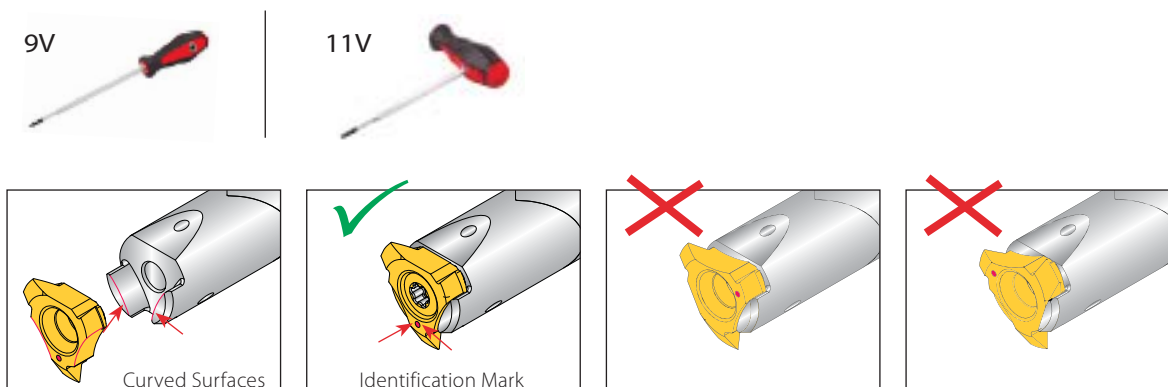

Always mount insert with the identification mark between the two curved surfaces on the toolholder.

Partial Profile 60°

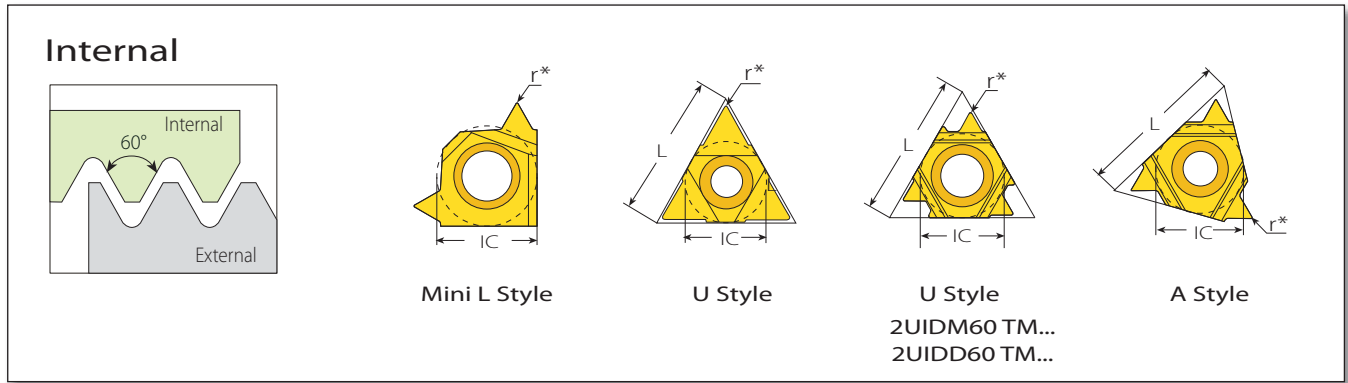

L Style



Insert Size		Pitch		Ordering Code	Dimensions mm	
IC	L mm	mm	tpi	Internal	r *	Toolholder
5.0L (Mini L)	-	0.5-1.5	48-16	5LIDA60TM...	0.04	TM.SC...5L
		1.0-2.0	24-11	5LIDN60TM...	0.06	CTM.SC...5L

U Style



2UIDM60 TM...
2UIDD60 TM...



Insert Size		Pitch		Ordering Code	Dimensions mm	
IC	L mm	mm	tpi	Internal	r *	Toolholder
1/4"U	11	0.5-1.5	48-16	2UIDA60TM...	0.05	TM.SC...2U
		1.5-2.0	16-12	2UIDB60TM...	0.06	CTM.SC...2U
		2.0-2.5	9-12	2UIDD60TM...	0.11	CTM2SC 14C17-65-2U
		2.5	10	2UIDM60TM...	0.11	
3/8"U	16	1.5-2.0	16-12	3UIDB60TM...	0.06	TM.SC...2U CTM.SC...2U
		2.5-3.5	10-7	3UIDE60TM...	0.14	
		4.0-6.0	6-4	3UIDH60TM...	0.25	
1/2"U	22	6.0-8.0	4-3	4UIDK60TM...	0.30	TM.SC D...4U

A Style



Insert Size		Pitch		Ordering Code	Dimensions mm	
IC	L mm	mm	tpi	Internal	r *	Toolholder
1/4"A	11	1.5-3.0	16-8	2AIDP60TM...	0.06	TM.SC...2A
3/8"A	16	2.0-4.0	12-6	3AIDT60TM...	0.08	TM.SC...3A

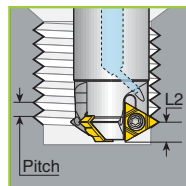

U Style
For Large Pitches

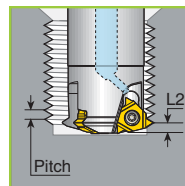

A Style
For Shorter L2

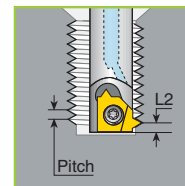

Mini-L Style
For Small Bores and Short L2

* The indicated radius (r) refers to the insert nose radius only.

Partial Profile 55°

Internal

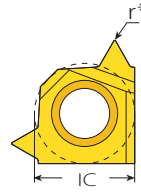
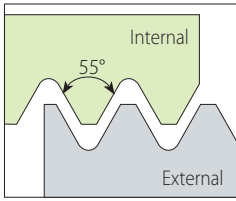

Mini L Style

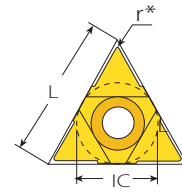

U Style

L Style



Insert Size	Pitch	Ordering Code	Dimensions mm	
IC	tpi	Internal	*r	Toolholder
5.0L (Mini L)	26-14	5LIDR55TM...	0.10	TM.SC...5L CTM. SC...5L

U Style



Insert Size		Pitch	Ordering Code	Dimensions mm	
IC	L mm	tpi	Internal	*r	Toolholder
1/4"U	11	48-16	2UIDA55TM...	0.11	TM.SC...2U CTM. SC...2U
		16-12	2UIDB55TM...	0.08	
		11-7	2UIDL55TM...	0.24	
3/8"U	16	16-12	3UIDB55TM...	0.08	TM.SC...3U
		11-7	3UIDL55TM...	0.24	
		6-4	3UIDH55TM...	0.27	
1/2"U	22	4-3	4UIDK55TM...	0.50	TM.SC D...4U

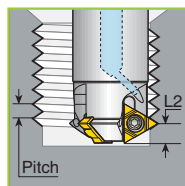

U Style
For Large Pitches

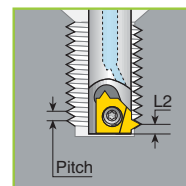

Mini-L Style
For Small Bores and Short L2

* The indicated radius (r) refers to the insert nose radius only.

ISO Metric

Internal

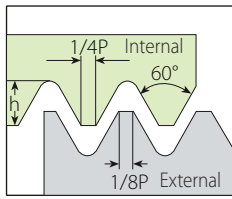

Defined by: R262 (DIN 13)
Tolerance class: 6g/6H

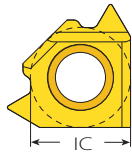

Mini L Style
5LI2.0ISOTM...

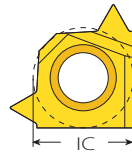

Mini L Style

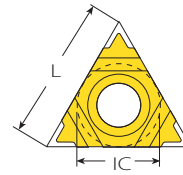

U Style

L Style



5LI2.0ISO TM...

Insert Size	Pitch	Ordering Code	Toolholder	Toolholder Cutting Diameter D2 (mm)
IC	mm	Internal	Toolholder	Adjusted D2
5.0L (Mini L)	1.0	5LI1.0ISOTM...	TM.SC...5L CTM.SC...5L	-
	1.5	5LI1.5ISOTM...		-
	2.0	5LI2.0ISOTM...		-

U Style



Insert Size	Pitch	Ordering Code	Toolholder	Toolholder Cutting Diameter D2 (mm)
IC	L mm	mm	Internal	* Adjusted D2
1/4"U	11	1.5	2UI1.5ISOTM...	For 1.5ISO change D2 to D2-1.0
		2.0	2UI2.0ISOTM...	For 2.0ISO change D2 to D2-1.15

* Correct the toolholder cutting diameter D2 according to adjustment, as indicated in the above table.

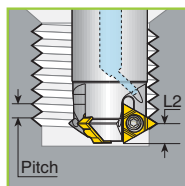

U Style
For Large Pitches

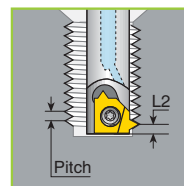

Mini-L Style
For Small Bores and Short L2

American UN - UNC; UNF; UNEF; UNS

Internal

Defined by: ANSI B1.1:74
Tolerance class: 2A/2B

Mini L Style
5LI14UNTM...
5LI12UNTM...

Mini L Style

U Style

L Style



Insert Size	Pitch	Ordering Code	Toolholder	Toolholder Cutting Diameter D2 (mm)
IC	tpi	Internal	Toolholder	Adjusted D2
5.0L (Mini L)	18	5LI18UNTM...	TM.SC...5L CTM.SC...5L	-
	16	5LI16UNTM...		
	14	5LI14UNTM...		
	12	5LI12UNTM...		

U Style



Insert Size	Pitch	Ordering Code	Toolholder	Toolholder Cutting Diameter D2 (mm)	
IC	L mm	tpi	Internal	* Adjusted D2	
1/4"U	11	14	2UI14UNTM...	TM2SC25W23-70-2U; TM3SC25W26-80-2U; TM4SC32W31-95-2U; TM2SC18C23-86-2U; TM3SC20C26-105-2U; TM4SC25C31-115-2U; CTM3SC20C26-110-2U; CTM4SC25C31-135-2U	For 14UN change D2 to D2-1.06
		12	2UI12UNTM...		For 12UN change D2 to D2-1.15

* Correct the toolholder cutting diameter D2 according to adjustment, as indicated in the above table.

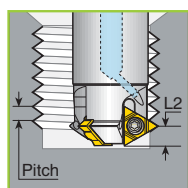

U Style
For Large Pitches

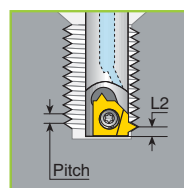

Mini-L Style
For Small Bores and Short L2

NPT

External / Internal

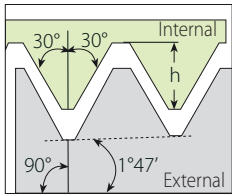

Defined by: USAS B2.1:1968
Tolerance class: Standard NPT

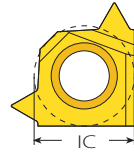

Mini L Style

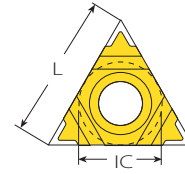

U Style

L Style



Insert Size	Pitch	Ordering Code	Toolholder	Toolholder Cutting Diameter D2 (mm)
IC	tpi	External/Internal		Adjusted D2
5.0L (Mini L)	18	5LEI18NPT-TM...	TM.SC...5L CTM.SC...5L	-

U Style



Insert Size	Pitch	Ordering Code	Toolholder	Toolholder Cutting Diameter D2 (mm)	
IC	L mm	tpi	Internal/External	* Adjusted D2	
1/4"U	11	14	2UEI14NPT-TM...	TM1SC16W15-40-2U; CTM1SC08C15-40-2U; CTM1SC11C15-60-2U	14.59
				TM2SC25W21-60-2U; CTM2SC14C21-65-2U; CTM2SC16C21-80-2U	20.49
	11	11.5	2UEI11.5NPT-TM...	TM2SC25W23-70-2U; TM2SC18C23-86-2U	22.63
				TM3SC25W26-80-2U; TM3SC20C26-105-2U; CTM3SC20C26-110-2U	25.63
3/8"U	16	11.5	3UEI11.5NPT-TM...	TM4SC32W31-95-2U; TM4SC25C31-115-2U; CTM4SC25C31-135-2U	30.63
				TM3SC32W36-95-3U; TM3SC32W36-145-3U; TM3SC25C36-125-3U; TM3SC28C36-144-3U	35.65
				TM4SC40W42-120-3U; TM4SCD42-16-3U	41.15
	16	8	3UEI8NPT-TM...	TM5SCD48-22-3U	47.15
				TM3SC32W36-95-3U; TM3SC32W36-145-3U; TM3SC25C36-125-3U; TM3SC28C36-144-3U	35.65
				TM4SC40W42-120-3U; TM4SCD42-16-3U	41.15
22	8	4UEI8NPT-TM...	TM5SC-D48-22-3U	47.15	
			TM6SC-D56-22-3U	55.15	
1/2"U	22	8	4UEI8NPT-TM...	TM6SC-D88-27-4U	88.06
				TM7SC-D98-32-4U	98.06

* Correct the toolholder cutting diameter D2 according to adjustment, as indicated in the above table.

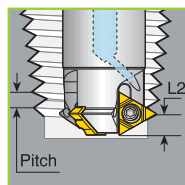

U Style
For Large Pitches

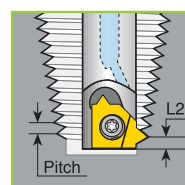

Mini-L Style
For Small Bores and Short L2

Trapez

Internal

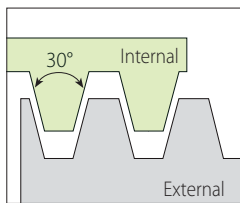

Defined by: DIN 103
Tolerance class: 7e/7H

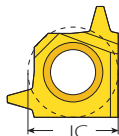

Mini L Style

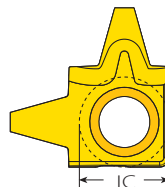

3/8" L

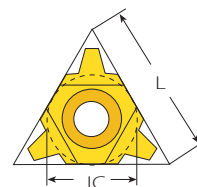

U Style

L Style



Insert Size	Pitch	Ordering Code	Application	Toolholder
IC	mm	Internal	Internal	
5.0L (Mini L)	2.0	5LI2.0TR-1TM...	TR16x2, TR20x2	TM.SC...5L CTM.SC...5L
	2.0	5LI2.0TR-2TM...	TR18x2	
3/8"L	6.0	3LI6.0TR-1TM...	(TR30-36)x6	TM1SC25W21-50-3L; CTM1SC1/2"C21-75-3L
	6.0	3LI6.0TR-2TM...	(TR115-130)x6	TM7SCD80-32-3L
	7.0	3LI7.0TRTM...	(TR38-44)x7	TM2SC25W28-75-3L; CTM2SC18C28-100-3L
	8.0	3LI8.0TR-1TM...	(TR46-52)x8	TM3SC32W33-90-3L; CTM3SC20C33-120-3L
	8.0	3LI8.0TR-2TM...	(TR175-240)x8	TM7SCD80-32-3L

U Style



Insert Size	Pitch	Ordering Code	Application	Toolholder	
IC	L mm	mm	Internal	Internal	
1/4"U	11	3.0	2UI3.0TR-1TM...	(TR22-TR30)x3	See pages 312-319
			2UI3.0TR-2TM...	(TR32-TR60)x3	
		4.0	2UI4.0TR-1TM...	(TR20-TR28)x4	
			2UI4.0TR-2TM...	(TR65-TR110)x4	
		5.0	2UI5.0TR-1TM...	TR22x5; TR28x5	
			2UI5.0TR-2TM...	TR24x5; TR26x5	

American ACME

Internal

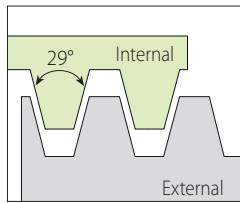

Defined by: ANSI B1.5: 1988
Tolerance class: 3G

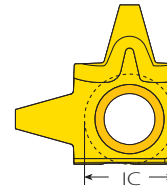

3/8" L

L Style



3/8" L

Insert Size	Pitch	Ordering Code	Application	Toolholder
IC	tpi	Internal	Internal	
3/8" L	5	3LI5ACMETM...	1¼-5ACME	
	4	3LI4ACME-1TM...	1⅜-4ACME	TM1SC25W21-50-3L; CTM1SC ½"C21-75-3L
		3LI4ACME-2TM...	1½-4ACME	
		3LI4ACME-3TM...	1¾-4ACME	TM2SC25W28-75-3L; CTM2SC18C28-100-3L
		3LI4ACME-4TM...	2-4ACME	
	3	3LI3ACME-1TM...	2¼-3ACME	
		3LI3ACME-2TM...	2½-3ACME	TM3SC32W33-90-3L; CTM3SC20C33-120-3L
		3LI3ACME-3TM...	2¾-3ACME	

Stub ACME

Internal

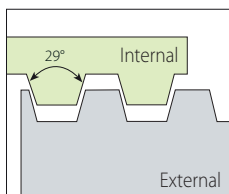

Defined by: ANSI B1.8: 1988
Tolerance class: 2G

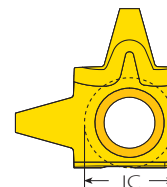

3/8" L

L Style



3/8" L

Insert Size	Pitch	Ordering Code	Application	Toolholder
IC	tpi	Internal	Internal	
3/8" L	5	3LI5STACMETM...	1¼-5STACME	
	4	3LI4STACME-1TM...	1⅜-4STACME	TM1SC25W21-50-3L; CTM1SC ½"C21-75-3L
		3LI4STACME-2TM...	1½-4STACME	
		3LI4STACME-3TM...	2-4STACME	
		3LI3STACME-1TM...	2¼-3STACME	
	3	3LI3STACME-2TM...	2½-3STACME	TM3SC32W33-90-3L; CTM3SC20C33-120-3L
		3LI3STACME-3TM...	2¾-3STACME	

TMSD

American Buttress

Internal

Defined by: ANSI B1.9.1973
Tolerance class: Class 2

Mini L Style 3/8" L 5/8 V

L Style

Insert Size	Pitch	Ordering Code	Application			
			IC	tpi	Internal	Internal
	5.0L (Mini L)	5LI16ABUT-TM...	16	Internal	0.875"-4.0" ABUT	TM2SC16W14-35-5L-ABUT CTM2SC10C14-50-5L-ABUT
					1.25"-4.0" ABUT	TM3SC20W18-45-5L-ABUT CTM3SC14C18-65-5L-ABUT
		5LI12ABUT-TM...	12	Internal	0.875"-6.0" ABUT	TM2SC16W14-35-5L-ABUT CTM2SC10C14-50-5L-ABUT
					1.25"-6.0" ABUT	TM3SC20W18-45-5L-ABUT CTM3SC14C18-65-5L-ABUT
		5LI10ABUT-TM...	10	Internal	0.875"-16.0" ABUT	TM2SC16W14-35-5L-ABUT CTM2SC10C14-50-5L-ABUT
					1.25"-16.0" ABUT	TM3SC20W18-45-5L-ABUT CTM3SC14C18-65-5L-ABUT
	3LI16ABUT-TM...	16	Internal	1.75"-4.0" ABUT	TM2SC25W26-80-3L-ABUT CTM2SC20C26-105-3L-ABUT	
				2.5"-4.0" ABUT	TM3SC32W35-105-3L-ABUT	
		12	Internal	1.75"-6.0" ABUT	TM2SC25W26-80-3L-ABUT CTM2SC20C26-105-3L-ABUT	
				2.5"-6.0" ABUT	TM3SC32W35-105-3L-ABUT	
				3.0"-6.0" ABUT	TM5SCD48-22-3L-ABUT	
				4.0"-6.0" ABUT	TM6SCD58-27-3L-ABUT	
3LI10ABUT-TM...	10	Internal	1.75"-6.0" ABUT	TM2SC25W26-80-3L-ABUT CTM2SC20C26-105-3L-ABUT		
			2.5"-6.0" ABUT	TM3SC32W35-105-3L-ABUT		
			3.0"-6.0" ABUT	TM5SCD48-22-3L-ABUT		
	8	Internal	1.75"-6.0" ABUT	TM2SC25W26-80-3L-ABUT CTM2SC20C26-105-3L-ABUT		
			2.5"-6.0" ABUT	TM3SC32W35-105-3L-ABUT		
			4.0"-6.0" ABUT	TM6SCD58-27-3L-ABUT		
3LI6ABUT-TM...	6	Internal	1.75"-6.0" ABUT	TM2SC25W26-80-3L-ABUT CTM2SC20C26-105-3L-ABUT		
			2.5"-6.0" ABUT	TM3SC32W35-105-3L-ABUT		
			3.0"-6.0" ABUT	TM5SCD48-22-3L-ABUT		
			4.0"-6.0" ABUT	TM6SCD58-27-3L-ABUT		

V Style

Insert Size	Pitch	Ordering Code	Application				
			IC	tpi	Internal	T	Internal
	5/8" V	5VI4ABUT-TM...	4	Internal	6	5.5"-24.0" ABUT	TM6SCD88-32-5V6-ABUT
					8	6.0"-24.0" ABUT	TM6SCD88-32-5V8-ABUT
					10	7.0"-24.0" ABUT	

API Round Casing & Tubing

Internal

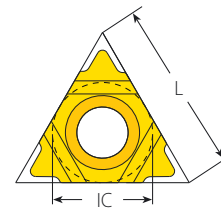
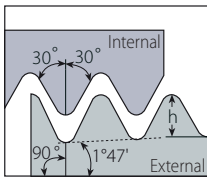

Defined by: API STD. 5B:1979
Tolerance class: Standard API RD

U Style



Insert Size		Pitch	Ordering Code		Toolholder Cutting Diameter D2 (mm)
IC	L mm	tpi	Internal	Toolholder	* Adjusted D2
1/4"U	11	10	2UI10APIRDTM...	TM2SC25W23-70-2U	21.44
				TM2SC18C23-86-2U	21.74
				TM3SC25W26-80-2U	24.44
				TM3SC20C26-105-2U	24.44
3/8"U	16	8	3UI8APIRDTM...	TM4SC32W31-95-2U	29.44
				TM4SC25C31-115-2U	29.44
				TM3SC32W36-95-3U	34.7
				TM3SC32W36-145-3U	
				TM3SC25C36-125-3U	
				TM3SC25C36-125-3U	40.2
TM4SC40W42-120-3U					
TM4SCD42-16-3U					
				TM5SCD48-22-3U	46.2
				TM6SCD56-22-3U	54.2

* Correct the toolholder cutting diameter D2 according to adjustment, as indicated in the above table.

Standard Toolholders - Weldon Shank (U Style)

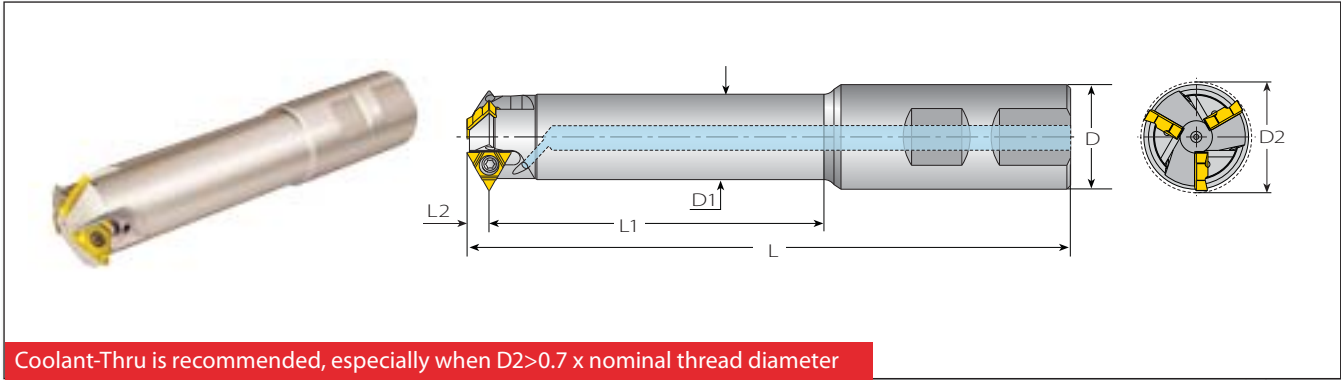

Weldon Shank for U Style Inserts

Insert Size	Ordering Code	Dimensions mm							No. of Flutes	Spare Parts	
		L	L1	L2	D	D1	D2	Z		Insert Screw	Torx Key
1/4"U	TM1SC16W15-40-2U	95	40		16	11.0	14.75*	1	SN2T	HK2T	
	TM2SC25W21-60-2U	123	60		25	16.0	20.65*	2			
	TM2SC25W23-70-2U	135	70	5.4	25	17.7	23.0	2			
	TM3SC25W26-80-2U	147	80		25	20.4	26.0	3			
	TM4SC32W31-95-2U	164	95		32	25.7	31.0	4			
3/8"U	TM3SC32W36-95-3U	166	95		32	29.0	36.5	3	SA3T	HK3T	
	TM3SC32W36-145-3U	225	145	8.0	32	28.0	36.5	3			
	TM4SC40W42-120-3U	201	120		40	34.2	42.0	4	SN3T		

Weldon Shank (U Style) Applications

Thread Applications for Partial Profile Inserts

Toolholder	Min. Thread Dia.							
	D2	ISO Coarse	ISO Fine	UNC	UN/UNF/UNEF/UNS	BSP (G)	Partial 55°	Trapez
TM1SC16W15-40-2U	14.75*	M18x2.5; M24x3.0	M16x0.5; M16x0.75; M16x1.0; M17x1.25; M17x1.5; M17x2.0	3/4-10	5/8-32UN; 5/8-28UN; 5/8-27UNS; 1/16-24UN; 1/4-20UN; 1/16-16UN; 3/4-14UNS; 3/4-12UN	3/8-19; 1/2-14; 1-11	1/16-14; 3/4-12; 7/8-11; 3/4-10; 7/8-9; 1-8; 1 1/8-7	TR22x3; TR24x3
TM2SC25W21-60-2U	20.65*	M24x3.0; M30x3.5	M22x0.5; M22x0.75; M22x1.0; M23x1.25; M23x1.5; M23x2.0	1-8; 1 1/8-7; 1 3/8-6	7/8-32UN; 7/8-28UN; 7/8-27UNS; 7/8-24UNS; 1-20UNEF; 1-18UNS; 1 1/16-16UN; 1-14UNS; 1 1/16-12UN; 1-10UNS	3/4-14; 1-11	1-26; 1-20; 1-16; 1-12; 1-10; 1 1/8-9; 1-8; 1 1/8-7	(TR26-TR60)x3
TM2SC25W23-70-2U	23.0	M27x3.0; M30x3.5; M36x4.0	M24x0.5; M24x0.75; M25x1.0; M25x1.25; M26x1.5; M26x2.0; M27x2.5	1 1/8-7	1-32UN; 1-28UN; 1-27UNS; 1-24UNS; 1-20UNEF; 1-18UNS; 1-16UN; 1-14UNS; 1-12UNF; 1 1/8-10UNS; 1 1/8-8UN	3/4-14; 1-11	1-26; 1-20; 1-16; 1 1/16-12; 1 1/8-9; 1 1/8-7	-
TM3SC25W26-80-2U	26.0	M30x3.5; M36x4.0	M27x0.5; M27x0.75; M28x1.0; M28x1.25; M28x1.5; M29x2.0; M30x2.5; M30x3.0	1 1/4-7; 1 3/8-6	1 1/8-28UN; 1 1/8-24UNS; 1 1/8-20UN; 1 1/8-18UNEF; 1 1/8-16UN; 1 1/8-14UNS; 1 1/8-12UNF; 1 1/4-10UNS; 1 3/16-8UN	7/8-14; 1-11	1 1/8-26; 1 1/8-20; 1 3/8-16; 1 3/8-12; 1 3/8-8; 1 1/4-7	-
TM4SC32W31-95-2U	31.0	M36x4.0	M32x0.5; M32x0.75; M33x1.0; M33x1.25; M33x1.5; M34x2.0; M34x2.5; M35x3.0; M36x3.5	1 1/2-6	1 1/16-28UN; 1 3/8-24UNS; 1 3/16-20UN; 1 3/16-18UNEF; 1 3/16-16UN; 1 3/16-14UNS; 1 3/16-12UNF; 1 3/8-10UNS; 1 3/8-8UN	1 1/8-11	1 3/8-26; 1 3/8-20; 1 3/8-16; 1 3/8-12; 1 7/16-8	-
TM3SC32W36-95-3U TM3SC32W36-145-3U	36.5	M42x4.5; M48x5.0; M56x5.5; M64x6.0	M39x1.5; M39x2.0; M40x2.5; M41x3.0; M42x3.5; M42x4.0	1 3/4-5; 2-4.5; 2 1/2-4	1 9/16-16UN; 1 1/8-14UNS; 1 9/16-12UN; 1 3/8-10UNS; 1 1/8-8UN; 1 1/8-6UN	1 1/4-11	1 1/8-16; 1 1/8-12; 1 3/8-8; 1 3/8-6; 1 3/4-5	-
TM4SC40W42-120-3U	42.0	M48x5.0; M56x5.5; M64x6.0	M45x1.5; M45x2.0; M46x2.5; M48x3.0; M48x3.5; M48x4.0	2-4.5; 2 1/2-4	1 3/4-16UN; 1 3/4-14UNS; 1 13/16-12UN; 1 3/16-8UN; 1 1/2-6UN	1 1/2-11	1 7/8-16; 1 7/8-12; 1 7/8-8; 2 1/4-6; 2-4.5	-

* For TR inserts use the CNC program (D2+0.25mm).

Weldon Shank (U Style) Applications (con't)

Thread Applications for Full Profile Inserts (ISO & UN)

Toolholder	Toolholder Cutting Diameter D2 (mm)	Pitch		Min. Thread Dia.	
		* Adjusted D2	mm	tpi	ISO Fine
TM2SC25W23-70-2U	22.0	1.5	-	M26x1.5	-
	21.85	2.0	-	M26x2.0	-
	21.94	-	14	-	1-14UNS
	21.85	-	12	-	1-12UNF
TM3SC25W26-80-2U	25.0	1.5	-	M28x1.5	-
	24.85	2.0	-	M29x2.0	-
	24.94	-	14	-	1 1/8-14UNF
	24.85	-	12	-	1 1/8-12UNF
TM4SC32W31-95-2U	30.0	1.5	-	M33x1.5	-
	29.85	2.0	-	M34x2.0	-
	29.94	-	14	-	1 3/8-14UNS
	29.85	-	12	-	1 3/8-12UNF

Thread Applications for Full Profile Inserts (NPT)

Toolholder	Toolholder Cutting Diameter D2 (mm)	Pitch	Cylindrical or Conical Pre-Drilled Hole	Cylindrical Pre-Drilled Hole
			* Adjusted D2	tpi
TM1SC16W15-40-2U	14.59	14	1/2-14NPT; 3/4-14NPT	-
TM2SC25W21-60-2U	20.49	14	3/4-14NPT	-
TM2SC25W23-70-2U	22.63	11.5	1-11.5NPT; 1 1/4-11.5NPT; 1 1/2-11.5NPT; 2-11.5NPT	-
TM3SC25W26-80-2U	25.63	11.5	1-11.5NPT; 1 1/4-11.5NPT; 1 1/2-11.5NPT; 2-11.5NPT	-
TM4SC32W31-95-2U	30.63	11.5	1 1/4-11.5NPT; 1 1/2-11.5NPT; 2-11.5NPT	-
TM3SC32W36-95-3U	35.65	11.5	1 1/4-11.5NPT; 1 1/2-11.5NPT; 2-11.5NPT	-
TM3SC32W36-145-3U				
TM3SC32W36-95-3U	35.65	8	-	2 1/2...10-8NPT
TM3SC32W36-145-3U				
TM4SC40W42-120-3U	41.15	11.5	1 1/2-11.5NPT; 2-11.5NPT	-
TM4SC40W42-120-3U	41.15	8	-	2 1/2...10-8NPT

** When the pre-drilled hole for 8NPT is conical, the thread can be machined in one pass.

Thread Applications for Full Profile Inserts (API Round)

Toolholder	Toolholder Cutting Diameter D2 (mm)	Pitch	Cylindrical or Conical Pre-Drilled Hole (for cylindrical 2 radial passes 50%/50%; for conical one radial pass)	Conical Pre-Drilled Hole only (one pass)	
			* Adjusted D2	tpi	Thread Dia.
TM2SC 25W23-70-2U	21.44	10	1.05x10APIRD (for UP TBG; UP TBG Long); 1.315...1.66x10APIRD (for TBG; UP TBG; UP TBG Long; Integral-Joint TBG)	-	
TM3SC 25W26-80-2U	24.44		1.66...2.875x10APIRD (for TBG; UP TBG; UP TBG Long; Integral-Joint TBG)		
TM4SC 32W31-95-2U	29.44		1.66...3.5x10APIRD (for TBG; UP TBG; UP TBG Long; Integral-Joint TBG)		
TM3SC 32W36-95-3U	34.7	8	2.375...13.375x8APIRD (for CSG; TBG; UP TBG; UP TBG Long); 4.5...5.5x8APIRD (for LCSG)	-	
TM3SC 32W36-145-3U			2.375...20x8APIRD (for CSG; TBG; UP TBG; UP TBG Long); 4.5...7.625x8APIRD (for LCSG)		8.625...20x8APIRD (for LCSG)
TM4SC 40W42-120-3U			40.2		2.875...20x8APIRD (for CSG; TBG; UP TBG; UP TBG Long); 4.5...7.625x8APIRD (for LCSG)

* Correct the toolholder cutting diameter D2 according to adjustment, as indicated in the above table.

Standard Toolholders - Carbide Cylindrical Shank (U Style)

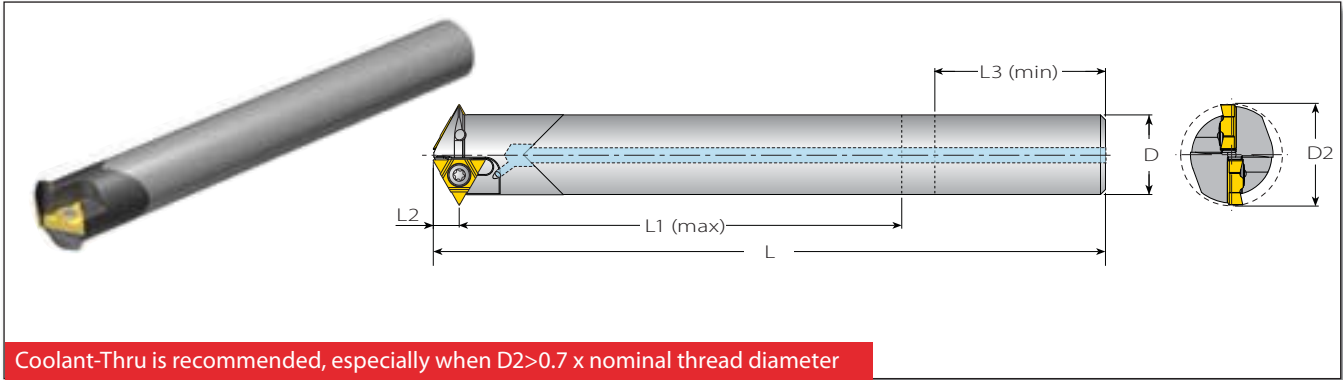

Carbide Cylindrical Shank for U Style Inserts

Insert Size	Ordering Code	Dimensions mm							Spare Parts	
		L	L1 (max)	L2	L3 (min)	D	D2	Z	Insert Screw	Torx Key
1/4"U	CTM1SC08C15-40-2U	109	40	5.4	18	8	14.75*	1	SN2T	HK2T
	CTM1SC11C15-60-2U	120	60		25	10.7	14.75*	1		
	CTM2SC14C17-65-2U**	132	65	5.4	30	14	17.9**	2		
	CTM2SC14C21-65-2U	136	65		30	14	20.65*	2		
	CTM2SC16C21-80-2U	135	80	34	16	20.65*	2			
	CTM3SC20C26-110-2U	165	110	40	20	26.0*	3			
	CTM4SC25C31-135-2U	186	135	46	25	31.0*	4			

* For TR inserts use the CNC program (D2+0.25mm).
 ** To be used only with inserts 2UIDD60TM... or 2UIDM60TM...
 For insert 2UIDD60 TM... use the CNC program (D2+0.7mm).

TMSD

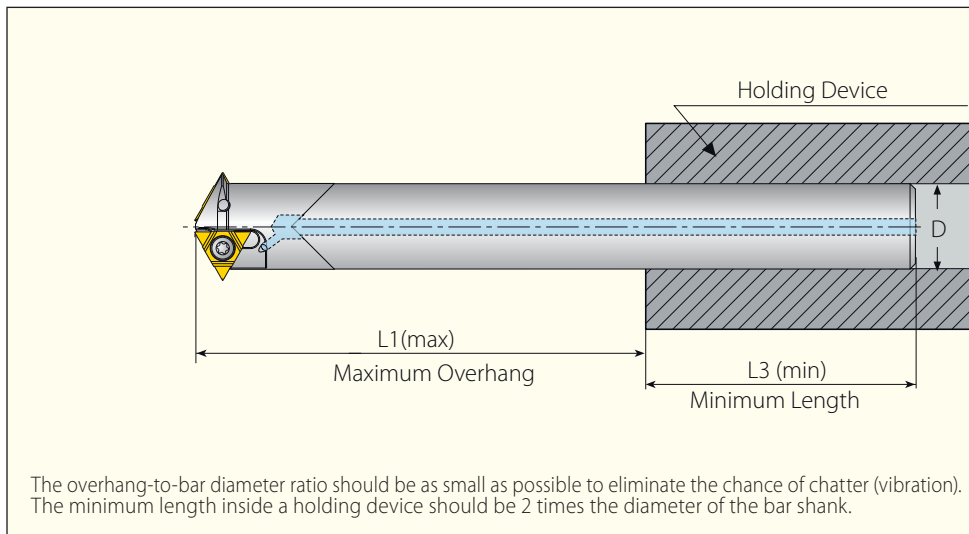

Carbide Cylindrical Shank (U Style) Applications

Thread Applications for Partial Profile Inserts

Toolholder		Min. Thread Dia.						
D2	ISO Coarse	ISO Fine	UNC	UN/UNF/UNEF/UNS	BSP (G)	Partial 55°	Trapez	
CTM1SC08C15-40-2U	14.75*	M18x2.5; M24x3.0; M30x3.5; M36x4.0	M16x0.5; M16x0.75; M16x1.0; M17x1.25; M17x1.5; M17x2.0	3/4-10; 7/8-9; 1-8; 1 1/8-7; 1 3/8-6	5/8-32UN; 5/8-28UN; 5/8-27UNS; 1 1/16-24UNEF; 1 1/16-20UN; 1 1/16-16UN; 3/4-14UNS; 1 1/16-12UN	1/2-14; 1-11	1 1/16-26; 1 1/16-20; 1 1/16-16; 1 1/16-14; 3/4-12; 7/8-11; 3/4-10; 7/8-9; 1-8; 1 1/8-7	TR22x3; TR24x3; TR20x4; TR22x5; TR24x5; TR26x5; TR28x5
CTM1SC11C15-60-2U	14.75*	M18x2.5; M24x3.0	M16x0.5; M16x0.75; M16x1.0; M17x1.25; M17x1.5; M17x2.0	3/4-10; 7/8-9; 1-8	5/8-32UN; 5/8-28UN; 5/8-27UNS; 1 1/16-24UNEF; 1 1/16-20UN; 1 1/16-16UN; 3/4-14UNS; 1 1/16-12UN	1/2-14; 1-11	1 1/16-26; 1 1/16-20; 1 1/16-16; 1 1/16-14; 3/4-12; 7/8-11; 3/4-10; 7/8-9	TR22x3; TR24x3
CTM2SC14C17-65-2U	17.2**	M20x2.5; M22x2.5	M21x2.0	7/8-9	7/8-10UNS; 1 3/16-12UN	-	-	-
CTM2SC14C21-65-2U	20.65*	M24x3.0; M30x3.5; M36x4.0	M22x0.5; M22x0.75; M22x1.0; M23x1.25; M23x1.5; M23x2.0	1-8; 1 1/8-7; 1 3/8-6	7/8-32UN; 7/8-28UN; 7/8-27UNS; 7/8-24UNS; 7/8-20UNEF; 1-18UNS; 1 1/16-16UN; 1-14UNS; 1 1/16-12UN; 1-10UNS	3/4-14; 1-11	1-26; 1-20; 1-16; 1-12; 1-10; 1 1/8-9; 1-8; 1 1/8-7	(TR26-TR60)x3; TR28x4; (TR65-TR110)x4; TR28x5
CTM2SC16C21-80-2U	20.65*	M24x3.0; M30x3.5	M22x0.5; M22x0.75; M22x1.0; M23x1.25; M23x1.5; M23x2.0	1-8; 1 1/8-7; 1 3/8-6	7/8-32UN; 7/8-28UN; 7/8-27UNS; 7/8-24UNS; 7/8-20UNEF; 1-18UNS; 1 1/16-16UN; 1-14UNS; 1 1/16-12UN; 1-10UNS	3/4-14; 1-11	1-26; 1-20; 1-16; 1-12; 1-10; 1 1/8-9; 1-8; 1 1/8-7	(TR26-TR60)x3
CTM3SC20C26-110-2U	26	M30x3.5; M36x4.0	M27x0.5; M27x0.75; M28x1.0; M28x1.25; M28x1.5; M29x2.0; M30x2.5; M30x3.0	1 1/4-7; 1 3/8-6	1 1/8-28UN; 1 1/8-24UNS; 1 1/8-20UN; 1 1/8-18UNEF; 1 1/8-16UN; 1 1/8-14UNS; 1 1/8-12UNF; 1 3/8-10UNS; 1 7/16-8UN	7/8-14; 1-11	1 1/8-26; 1 1/8-20; 1 1/8-16; 1 1/8-12; 1 3/16-8; 1 1/4-7	(TR40-TR60)x3 (TR65-TR110)x4
CTM4SC25C31-135-2U	31	M36x4.0	M32x0.5; M32x0.75; M33x1.0; M33x1.25; M33x1.5; M34x2.0; M34x2.5; M35x3.0; M36x3.5	1 1/2-6	1 1/2-28UN; 1 1/2-24UNS; 1 1/2-20UN; 1 1/2-18UNEF; 1 3/8-16UN; 1 3/8-14UNS; 1 3/8-12UNF; 1 3/8-10UNS; 1 7/16-8UN	1 1/8-11	1 5/16-26; 1 5/16-20; 1 3/8-16; 1 3/8-12; 1 1/8-8	(TR50-TR60)x3 (TR65-TR110)x4

* For TR inserts use the CNC program (D2+0.25mm).

** To be used only with inserts 2UIDD60TM... or 2UIDM60TM...

For insert 2UIDD60 TM... use the CNC program (D2+0.7mm).

Thread Applications for Full Profile Inserts (ISO & UN)

Toolholder	Toolholder Cutting Diameter D2 (mm)	Pitch		Min. Thread Dia.		
		* Adjusted D2	mm	tpi	ISO Fine	UN/UNF/UNEF/UNS
CTM3SC20C26-110-2U	25.0		1.5	-	M28x1.5	-
	24.85		2.0	-	M29x2.0	-
	24.94		-	14	-	1 1/8-14UNS
	24.85		-	12	-	1 1/8-12UNF
CTM4SC25C31-135-2U	30.0		1.5	-	M33x1.5	-
	29.85		2.0	-	M34x2.0	-
	29.94		-	14	-	1 3/8-14UNS
	29.85		-	12	-	1 3/8-12UNF

* Correct the toolholder cutting diameter D2 according to adjustment, as indicated in the above table.

Thread Applications for Full Profile Inserts (NPT)

Toolholder	Toolholder Cutting Diameter D2 (mm)	Pitch	Cylindrical or Conical Pre-Drilled Hole		
			* Adjusted D2	tpi	NPT Threading by 1 Radial Pass
CTM1SC08C15-40-2U	14.59	14	14	1/2-14NPT; 3/4-14NPT	-
CTM1SC11C15-60-2U					-
CTM2SC14C21-65-2U	20.49	14	14	3/4-14NPT	-
CTM2SC16C21-80-2U					-
CTM3SC20C26-110-2U	25.63	11.5		1-11.5NPT; 1 1/4-11.5NPT; 1 1/2-11.5NPT; 2-11.5NPT	-
CTM4SC25C31-135-2U	30.63	11.5		1 1/4-11.5NPT; 1 1/2-11.5NPT; 2-11.5NPT	-

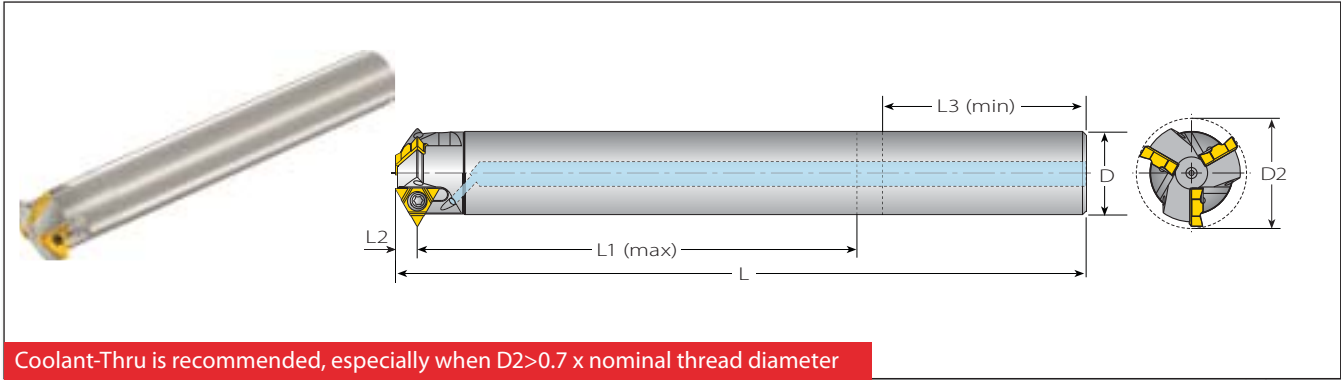

* Correct the toolholder cutting diameter D2 according to adjustment, as indicated in the above table.

Standard Toolholders - Steel Cylindrical Shank (U Style)



Steel Cylindrical Shank for U Style Inserts

Spare Parts

Insert Size	Ordering Code	Dimensions mm			No. of Flutes					
IC		L	L1 (max)	L2	L3 (min)	D	D2	Z	Insert Screw	Torx Key
1/4"U	TM2SC18C23-86-2U	166	86	5.4	40	18	23.3	2	SN2T	HK2T
	TM3SC20C26-105-2U	186	105		40	20	26	3		
	TM4SC25C31-115-2U	196	115		46	25	31	4		
3/8"U	TM3SC25C36-125-3U	193	125	8.0	46	25	36.5	3	SA3T	HK3T
	TM3SC28C36-144-3U	222	144		60	28	36.5	3		

Steel Cylindrical Shank (U Style) Applications

Thread Applications for Partial Profile Inserts

Toolholder	Min. Thread Dia.						
	D2	ISO Coarse	ISO Fine	UNC	UN/UNF/UNEF/UNS	BSP (G)	Partial 55°
TM2SC18C23-86-2U	23.3	M27x3.0; M30x3.5; M36x4.0	M24x0.5; M25x0.75; M25x1.0; M25x1.25; M26x1.5; M26x2.0; M27x2.5	1 1/8-7	1-32UN; 1-28UN; 1-27UN; 1-24UNS; 1-20UNEF; 1-18UNS; 1-16UN; 1-14UNS; 1 1/16-12UN; 1 1/8-10UNS; 1 1/8-8UN	3/4-14; 1-11	1-26; 1-20; 1 1/8-16; 1 1/8-12; 1 1/8-9; 1 1/8-7
TM3SC20C26-105-2U	26	M30x3.5; M36x4.0	M27x0.5; M27x0.75; M28x1.0; M28x1.25; M28x1.5; M29x2.0; M30x2.5; M30x3.0	1 1/4-7; 1 1/8-6	1 1/8-28UN; 1 1/8-24UNS; 1 1/8-20UN; 1 1/8-18UNEF; 1 1/8-16UN; 1 1/8-14UNS; 1 1/8-12UNF; 1 1/8-10UNS; 1 1/8-8UN	7/8-14; 1-11	1 1/8-26; 1 1/8-20; 1 3/16-16; 1 3/16-12; 1 3/16-8; 1 1/4-7
TM4SC25C31-115-2U	31	M36x4.0	M32x0.5; M32x0.75; M33x1.0; M33x1.25; M33x1.5; M34x2.0; M34x2.5; M35x3.0; M36x3.5	1 1/2-6	1 1/16-28UN; 1 1/2-24UNS; 1 1/2-20UN; 1 1/2-18UNEF; 1 1/2-16UN; 1 1/2-14UNS; 1 1/2-12UNF; 1 1/2-10UNS; 1 1/2-8UN	1 1/8-11	1 1/16-26; 1 1/16-20; 1 1/8-16; 1 1/8-12; 1 1/16-8
TM3SC25C36-125-3U TM3SC28C36-144-3U	36.5	M42.5x4.5; M48x5.0; M56x5.5; M64x6.0	M39x1.5; M40x2.5; M41x3.0; M42x3.5; M42x4.0	1 3/4-5; 2-4.5; 2 1/2-4	1 1/16-16UN; 1 1/8-14UNS; 1 1/16-12UN; 1 1/8-10UNS; 1 1/8-8UN; 1 1/8-6UN	1 1/4-11	1 1/8-16; 1 1/8-12; 1 1/8-8; 1 1/8-6; 1 1/4-5

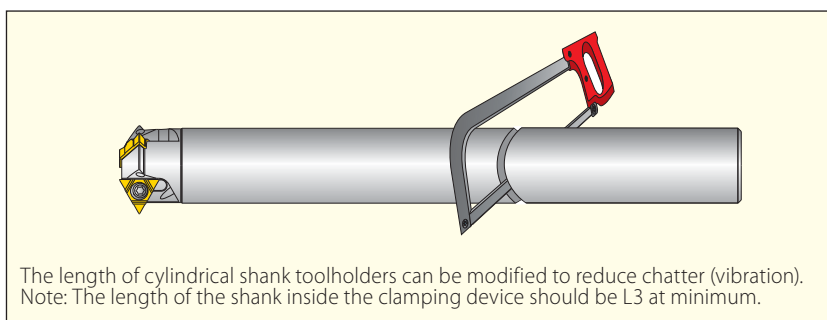

Steel Cylindrical Shank (U Style) Applications (con't)

Thread Applications for Full Profile Inserts (ISO & UN)

Toolholder	Toolholder Cutting Diameter D2 (mm)	Pitch		Min. Thread Dia.	
		* Adjusted D2	mm	tpi	ISO Fine
TM2SC18C23-86-2U	22.00	1.5	-	M26x1.5	-
	21.85	2.0	-	M26x2.0	-
	21.94	-	14	-	1-14UNS
	21.85	-	12	-	1-12UNF
TM3SC20C26-105-2U	25.00	1.5	-	M28x1.5	-
	24.85	2.0	-	M29x2.0	-
	24.94	-	14	-	1 1/8-14UNS
	24.85	-	12	-	1 1/8-12UNF
TM4SC25C31-115-2U	30.00	1.5	-	M33x1.5	-
	29.85	2.0	-	M34x2.0	-
	29.94	-	14	-	1 3/8-14UNS
	29.85	-	12	-	1 3/8-12UNF

Thread Applications for Full Profile Inserts (NPT)

Toolholder	Toolholder Cutting Diameter D2 (mm)	Pitch	Cylindrical or Conical Pre-Drilled Hole	Cylindrical Pre-Drilled Hole
			* Adjusted D2	tpi
TM2SC18C23-86-2U	22.63	11.5	1-11.5NPT; 1 1/4-11.5NPT; 1 1/2-11.5NPT; 2-11.5NPT	-
TM3SC20C26-105-2U	25.63	11.5	1-11.5NPT; 1 1/4-11.5NPT; 1 1/2-11.5NPT; 2-11.5NPT	-
TM4SC25C31-115-2U	30.63	11.5	1 1/4-11.5NPT; 1 1/2-11.5NPT; 2-11.5NPT	-
TM3SC25C36-125-3U	35.65	11.5	1 1/4-11.5NPT; 1 1/2-11.5NPT; 2-11.5NPT	-
TM3SC28C36-144-3U				
TM3SC25C36-125-3U	35.65	8	-	2 1/2...10-8NPT
TM3SC28C36-144-3U				

** When the pre-drilled hole for 8NPT is conical, the thread can be machined in one pass.

Thread Applications for Full Profile Inserts (API Round)

Toolholder	Toolholder Cutting Diameter D2 (mm)	Pitch	Cylindrical or Conical Pre-Drilled Hole (for cylindrical 2 radial passes 50%/50%; for conical one radial pass)	Conical Pre-Drilled Hole only (one pass)
			* Adjusted D2	tpi
TM2SC 18C23-86-2U	21.74	10	1.05x10APIRD (for UP TBG; UP TBG Long); 1.315...1.66x10APIRD (for TBG; UP TBG; UP TBG Long; Integral-Joint TBG)	-
TM3SC 20C26-105-2U	24.44		1.66...2.875x10APIRD (for TBG; UP TBG; UP TBG Long; Integral-Joint TBG)	
TM4SC 25C31-115-2U	29.44		1.66...3.5x10APIRD (for TBG; UP TBG; UP TBG Long; Integral-Joint TBG)	
TM3SC 25C36-125-3U	34.7	8	2.375...20x8APIRD (for CSG; TBG; UP TBG; UP TBG Long);	8.625...9.625x8APIRD (for LCSG)
TM3SC 28C36-144-3U			4.5...7.625x8APIRD (for LCSG)	8.625...20x8APIRD (for LCSG)

* Correct the toolholder cutting diameter D2 according to adjustment, as indicated in the above table.

Shell Mill (U Style)

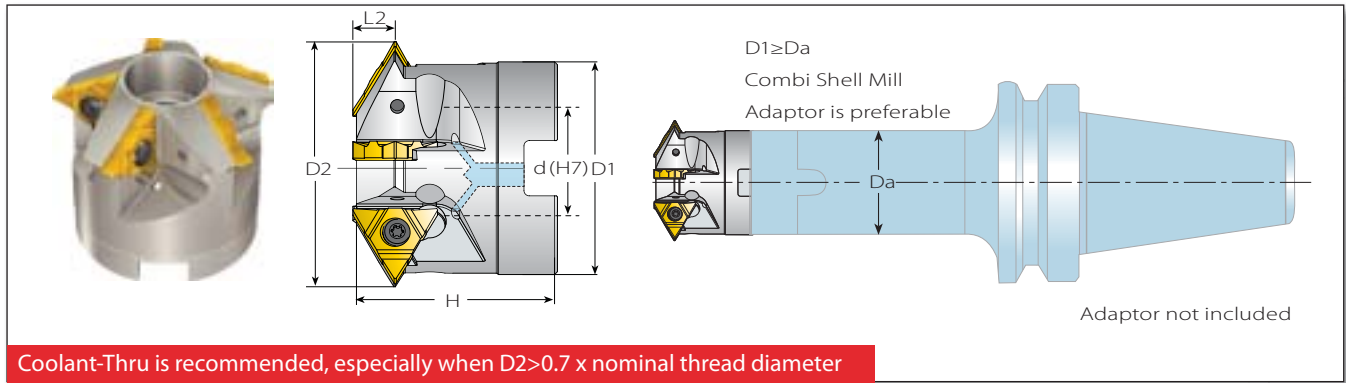

Shell Mill for U Style Inserts

Insert Size	Ordering Code	Dimensions mm						No. of Flutes	Spare Parts			
		D1	D2	d(H7)	H	L2	Z		Insert Screw	Torx Key	Holder Screw	Holder Screwdriver
3/8"U	TM4SC-D42-16-3U	34	42	16	40	8.0	4	SN3T	HK3T	SA5T-C5 (M8x1.25x28)	TK5T	
	TM5SC-D48-22-3U	40	48	22	40	8.0	5			M10x1.50x35	-	
	TM6SC-D56-22-3U	48	56	22	40	8.0	6			-	-	
1/2"U	TM6SC-D88-27-4U	76	88	27	50	10.8	6	SA4T	HK4T	M12x1.75x40	-	
	TM7SC-D98-32-4U	85	98	32	55	10.8	7			M16x2.0x40		

Shell Mill (U Style) Applications

Thread Applications for Partial Profile Inserts

Toolholder	Min. Thread Dia.						
	D2	ISO Coarse	ISO Fine	UNC	UN/UNF/UNEF/UNS	BSP (G)	Partial 55°
TM4SC-D42-16-3U	42	M48x5.0; M56x5.5; M64x6.0;	M45x1.5; M45x2.0; M46x2.5; M48x3.0; M48x3.5; M48x4.0	2-4.5; 2½ - 4	1¼-16UN; 1¼-14UNS; 1½-12UN; 1½-8UN; 1½-6UN	1½ - 11	1½-16; 1½-12; 1½-8; 1½-6; 2-4.5
TM5SC-D48-22-3U	48	M56x5.5; M64x6.0	M52x1.5; M52x2.0; M52x2.5; M52x3.0; M55x4.0	2¼ - 4.5; 2½ - 4	2-16UN; 2-14UN; 2-12UN; 2¼-10UNS; 2½-8UN; 2½-6UN	1¾ - 11	2-16; 2¼-12; 2¼-8; 2¼-6; 3-5; 3½-4.5; 2¼-4
TM6SC-D56-22-3U	56	M64x6.0	M60x1.5; M60x2.0; M60x2.5; M60x3.0; M64x4.0	2½ - 4	2¾-16UN; 2¾-14UN; 2¾-12UN; 2½-10UNS; 2¾-8UN; 2½-6UN	2 - 11	2½-16; 2½-12; 2½-8; 2¾-6; 3-5; 3½-4.5; 4¼-4
TM6SC-D88-27-4U	88	-	M95x6.0; M125x8	4-4	4¼-4UN	-	4-3; 4¼-4
TM7SC-D98-32-4U	98	-	M105x6.0; M125x8	-	4¼-4UN	-	4¼-4

TMSD

Shell Mill (U Style) Applications (con't)

Thread Applications for Full Profile Inserts (NPT)

Toolholder	Toolholder Cutting Diameter D2 (mm)	Pitch	Cylindrical or Conical Pre-Drilled Hole	Cylindrical Pre-Drilled Hole
	* Adjusted D2	tpi	NPT Threading by 1 Radial Pass	**NPT Threading by 2 Radial Passes (50% / 50%)
TM4SC-D42-16-3U	41.15	11.5	1 1/2-11.5NPT; 2-11.5NPT	-
TM4SC-D42-16-3U	41.15	8	-	2 1/2...10-8NPT
TM5SC-D48-22-3U	47.15	11.5	2-11.5NPT	-
TM5SC-D48-22-3U	47.15	8	-	2 1/2...10-8NPT
TM6SC-D56-22-3U	55.15	8	-	2 1/2...10-8NPT
TM6SC-D88-27-4U	88.06	8	3 1/2"...160D-8NPT	160D...240D-8NPT
TM7SC-D98-32-4U	98.06	8	4"...160D-8NPT	160D...240D-8NPT

** When the pre-drilled hole for 8NPT is conical, the thread can be machined in one pass.

Thread Applications for Full Profile Inserts (API Round)

Toolholder	Toolholder Cutting Diameter D2 (mm)	Pitch	Cylindrical or Conical Pre-Drilled Hole (for cylindrical 2 radial passes 50%/50%; for conical one radial pass)	Conical Pre-Drilled Hole only (one pass)
	* Adjusted D2	tpi	Thread Dia.	
TM4SC-D42-16-3U	40.2	8	2.875...20x8APIRD (for CSG; TBG; UP TBG; UP TBG Long); 4.5...7.625x8APIRD (for LCSG)	8.625...20x8APIRD (for LCSG)
TM5SC-D48-22-3U	46.2		3.5...20x8APIRD (for CSG; TBG; UP TBG; UP TBG Long); 4.5...7.625x8APIRD (for LCSG)	
TM6SC-D56-22-3U	54.2		4...20x8APIRD (for CSG; TBG; UP TBG; UP TBG Long); 4.5...7.625x8APIRD (for LCSG)	

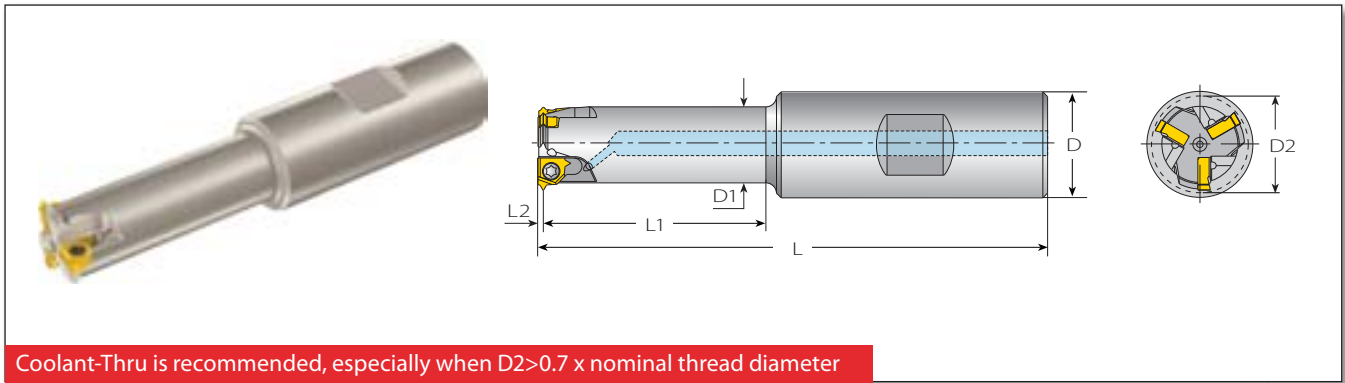

* Correct the toolholder cutting diameter D2 according to adjustment, as indicated in the above table.

Standard Toolholders - Weldon Shank (L Style - Mini L)



Weldon Shank for Mini-L Style Inserts

Spare Parts

Insert Size	Ordering Code	Dimensions mm							No. of Flutes	Spare Parts	
		L	L1	L2	D	D1	D2	Z			
5.0L (Mini L)	TM1SC16W13-29-5L	81	29	1.1	16	9.8	13.0	1	SN5LTR	Torx Key	
	TM2SC16W14-33-5L	85	33		16	10.3	13.5	2			
	TM3SC20W18-42-5L	96	42	1.87	20	14.3	17.7	3			
	TM2SC16W14-35-5L-ABUT	88	35		16	10.3	14.0	2			
	TM3SC20W18-45-5L-ABUT	100	45		20	14.3	18.2	3			

Weldon Shank (L Style - Mini L) Applications

Thread Applications for Partial Profile Inserts

Toolholder		Min. Thread Dia.						
D2	ISO Coarse	ISO Fine	UNC	UN/UNF/UNEF/UNS	BSP (G)	Partial 55°	Trapez	
TM1SC16W13-29-5L	13	M16x2	M14x0.5; M14x0.75; M14.5x1.0; M15x1.5; M17x2.0	5/8-11	5/16-32UN; 5/16-28UN; 5/16-27UNS; 5/16-24UNEF; 5/8-20UN; 5/8-18UNF; 5/8-16UN; 5/8-14UNS; 5/8-12UN	3/8-19	5/8-14 TR16X2; TR18X2	
TM2SC16W14-33-5L	13.5	M16x2	M15x0.5; M15x0.75; M15x1.0; M16x1.5; M17x2.0	-	5/8-32UN; 5/8-28UN; 5/8-27UNS; 5/8-24UNEF; 5/8-20UN; 5/8-18UNF; 5/8-16UN; 5/8-14UNS; 11/16-12UN	3/8-19	11/16-14 TR16X2; TR18X2	
TM3SC20W18-42-5L	17.7	-	M19x0.5; M19x0.75; M19x1.0; M20x1.5; M20x2.0	-	3/4-32UN; 3/4-28UN; 7/8-27UNS; 3/4-24UNS; 13/16-20UNEF; 7/8-18UNS; 13/16-16UN; 7/8-14UNF; 13/16-12UN	1/2-14	- TR20X2	

Thread Applications for Full Profile Inserts (ISO, UN, NPT)

Toolholder		Min. Thread Dia.		
D2	ISO Fine	UN/UNF/UNEF/UNS	NPT	
TM1SC16W13-29-5L	13	M14.5x1.0; M15x1.5; M17x2.0	5/8-18UNF; 5/8-16UN; 5/8-14UNS; 5/8-12UN	3/8-18NPT
TM2SC16W14-33-5L	13.5	M15x1.0; M16x1.5; M17x2.0	5/8-18UNF; 5/8-16UN; 5/8-14UNS; 11/16-12UN	3/8-18NPT
TM3SC20W18-42-5L	17.7	M19x1.0; M20x1.5; M20x2.0	7/8-18UNS; 13/16-16UN; 7/8-14UNF; 13/16-12UN	-

Thread Applications for Full Profile American Buttress Inserts

Toolholder		Thread Dia.
D2	American Buttress	
TM2SC16W14-35-5L-ABUT	14.0	(0.875"-4")-16; (0.875"-6")-12; (0.875"-16")-10
TM3SC20W18-45-5L-ABUT	18.2	(1.25"-4")-16; (1.25"-6")-12; (1.25"-16")-10

Standard Toolholders - Carbide Cylindrical Shank (L Style - Mini L)

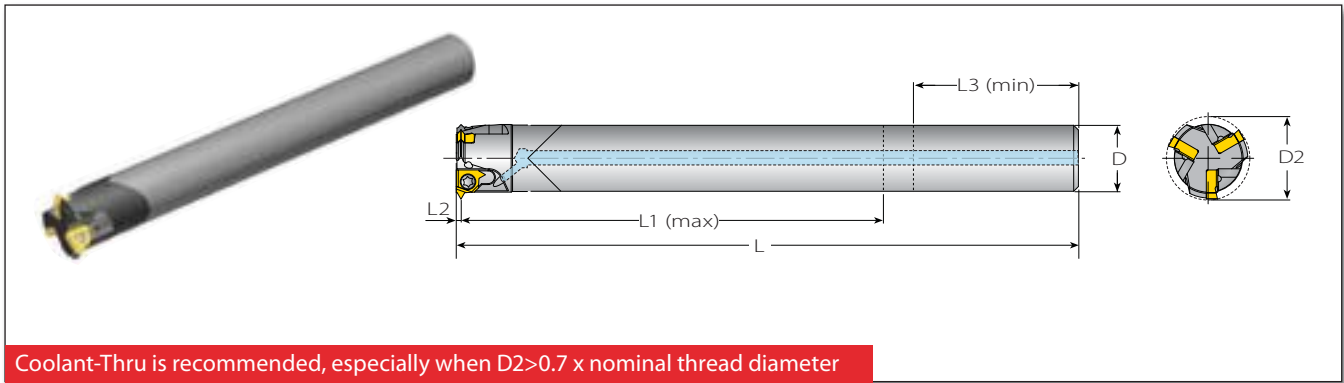

Carbide Cylindrical Shank for Mini-L Style Inserts

Carbide Cylindrical Shank for Mini-L Style Inserts									Spare Parts		
Insert Size	Ordering Code	Dimensions mm							No. of Flutes		
IC		L	L1 (max)	L2	L3 (min)	D	D2	Z	Insert Screw	Torx Key	
5.0L (Mini L)	CTM1SC09C13-43-5L	109	43	1.1	20	9.5	13.0	1	SN5LTR	K7T	
	CTM2SC10C14-50-5L	116	50		22	10	13.5	2			
	CTM3SC14C18-65-5L	132	65	30	14	17.7	3				
	CTM2SC10C14-50-5L-ABUT	116	50	1.87	22	10	14.0	2			
	CTM3SC14C18-65-5L-ABUT	132	65		30	14	18.2	3			

TMSD

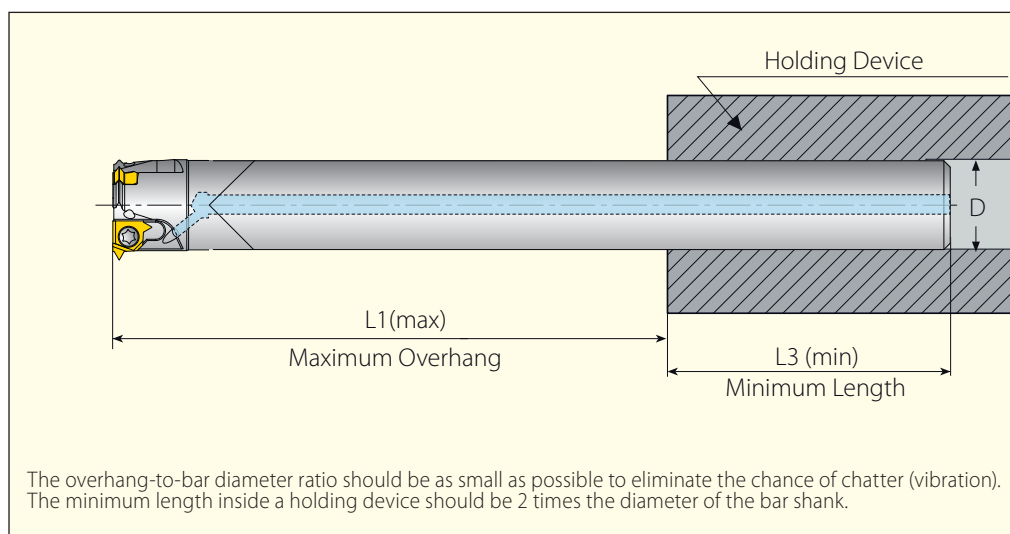

Carbide Cylindrical Shank (L Style - Mini L) Applications

Thread Applications for Partial Profile Inserts

Toolholder		Min. Thread Dia.						
D2	ISO Coarse	ISO Fine	UNC	UN/UNF/UNEF/UNS	BSP (G)	Partial 55°	Trapez	
CTM1SC09C13-43-5L	13	M16x2	M14x0.5; M14x0.75; M14.5x1.0; M15x1.5; M17x2.0	5/8-11	5/16-32UN; 5/16-28UN; 5/16-27UNS; 5/16-24UNEF; 5/8-20UN; 5/8-18UNF; 5/8-16UN; 5/8-14UNS; 5/8-12UN	3/8-19	5/8-14	TR16X2; TR18X2
CTM2SC10C14-50-5L	13.5	M16x2	M15x0.5; M15x0.75; M15x1.0; M16x1.5; M17x2.0	-	5/8-32UN; 5/8-28UN; 5/8-27UNS; 5/8-24UNEF; 5/8-20UN; 5/8-18UNF; 5/8-16UN; 5/8-14UNS; 11/16-12UN	3/8-19	11/16-14	TR16X2; TR18X2
CTM3SC14C18-65-5L	17.7	-	M19x0.5; M19x0.75; M19x1.0; M20x1.5; M20x2.0	-	3/4-32UN; 3/4-28UN; 7/8-27UNS; 3/4-24UNS; 13/16-20UNEF; 7/8-18UNS; 13/16-16UN; 7/8-14UNF; 13/16-12UN	1/2-14	-	TR20X2

Thread Applications for Full Profile Inserts (ISO, UN, NPT)

Toolholder		Min. Thread Dia.		
D2	ISO Fine	UN/UNF/UNEF/UNS	NPT	
CTM1SC09C13-43-5L	13	M14.5x1.0; M15x1.5; M17x2.0	5/8-18UNF; 5/8-16UN; 5/8-14UNS; 5/8-12UN	3/8-18NPT
CTM2SC10C14-50-5L	13.5	M15x1.0; M16x1.5; M17x2.0	5/8-18UNF; 5/8-16UN; 5/8-14UNS; 11/16-12UN	3/8-18NPT
CTM3SC14C18-65-5L	17.7	M19x1.0; M20x1.5; M20x2.0	7/8-18UNS; 13/16-16UN; 7/8-14UNF; 13/16-12UN	-

Thread Applications for Full Profile American Buttress Inserts

Toolholder		Thread Dia.
D2	American Buttress	
CTM2SC10C14-50-5L-ABUT	14.0	(0.875"-4")-16; (0.875"-6")-12; (0.875"-16")-10
CTM3SC14C18-65-5L-ABUT	18.2	(1.25"-4")-16; (1.25"-6")-12; (1.25"-16")-10

TMSD

Standard Toolholders - Weldon Shank (L Style - 3/8" L)

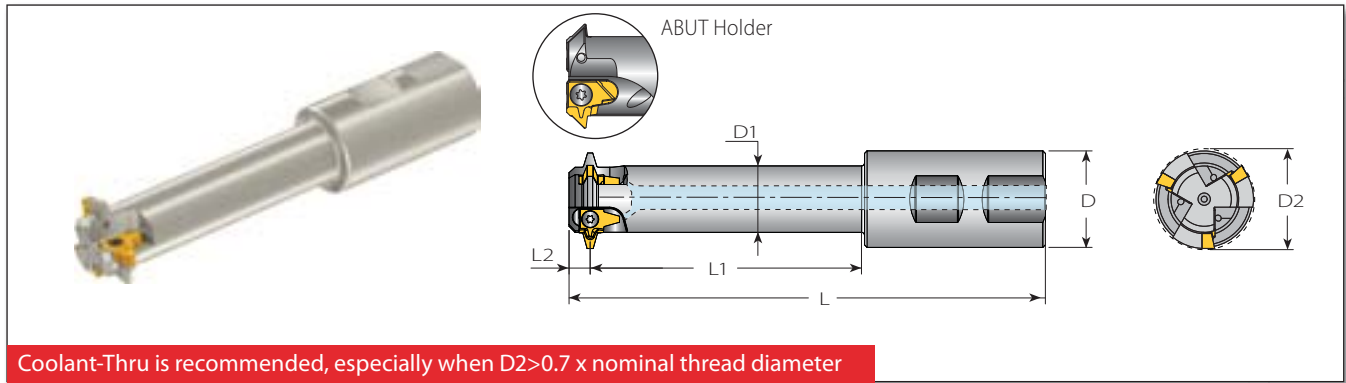

Weldon Shank for 3/8" L Style Inserts

Weldon Shank for 3/8" L Style Inserts									Spare Parts		
Insert Size	Ordering Code	Dimensions mm							No. of Flutes		
IC	Toolholder	L	L1	L2	D	D1	D2	Z	Insert Screw	Torx Key	
3/8" L	TM1SC25W21-50-3L	115	50	7.0	25	12.7	21.6	1	SN3T	HK3T	
	TM2SC25W28-70-3L	135	70		25	18.1	28.5	2	SA3T		
	TM3SC32W33-90-3L	158	90	32	22.0	33.5	3	SN3T			
	TM2SC25W26-80-3L-ABUT	143	80	4.7	25	20.1	26.4	2	SA3T		
	TM3SC32W35-105-3L-ABUT	172	105		32	28.0	35.5	3			

TMSD

Weldon Shank (L Style - 3/8" L) Applications

Thread Applications for Partial Profile Inserts

Toolholder	Min. Thread Dia.			
	D2	Trapez	American ACME	Stub ACME
TM1SC25W21-50-3L	21.6	(TR30-36)x6	1¼-5; 1⅜-4; 1½-4	1¼-5; 1⅜-4; 1½-4
TM2SC25W28-70-3L	28.5	(TR38-44)x7	1¾-4	-
TM3SC32W33-90-3L	33.5	(TR46-52)x8	2-4; 2¼-3; 2½-3; 2¾-3	2-4; 2¼-3; 2½-3; 2¾-3

Thread Applications for Full Profile American Buttress Inserts

Toolholder	Thread Dia.	
	D2	American Buttress
TM2SC25W26-80-3L-ABUT	26.4	(1.75"-4")-16; (1.75"-6")-12; (1.75"-6")-10; (1.75"-6")-8; (1.75"-6")-6
TM3SC32W35-105-3L-ABUT	35.5	(2.5"-4")-16; (2.5"-6")-12; (2.5"-6")-10; (2.5"-6")-8; (2.5"-6")-6

Standard Toolholders - Carbide Cylindrical Shank (L Style - 3/8" L)

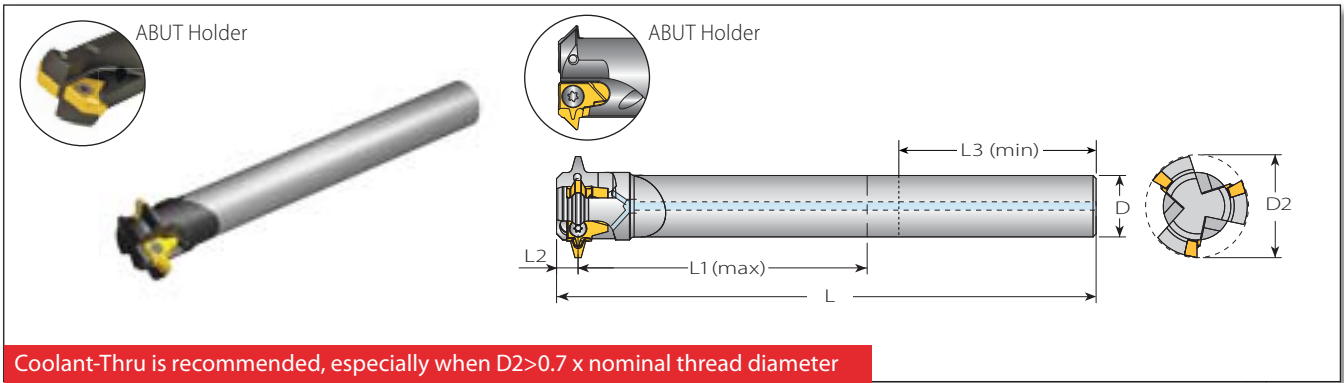

Coolant-Thru is recommended, especially when $D2 > 0.7 \times$ nominal thread diameter

Carbide Cylindrical Shank for 3/8" L Style Inserts

Spare Parts

Insert Size	Ordering Code	Dimensions mm							No. of Flutes		
IC	Toolholder	L	L1(max)	L2	L3(min)	D	D2	Z	Insert Screw	Torx Key	
3/8" L	CTM1SC1/2"C21-75-3L	115	75		40	12.7	21.6	1	SN3T	HK3T	
	CTM2SC18C28-100-3L	155	100	7.0	46	18	28.5	2	SA3T		
	CTM3SC20C33-120-3L	176	120		46	20	33.5	3	SN3T		
	CTM2SC20C26-105-3L-ABUT	172.5	105	4.7	40	20	26.4	2	SA3T		

Carbide Cylindrical Shank (L Style - 3/8" L) Applications

Thread Applications for Partial Profile Inserts

Toolholder	Min. Thread Dia.			
	D2	Trapez	American ACME	Stub ACME
CTM1SC1/2"C21-75-3L	21.6	(TR30-36)x6	1 1/4-5; 1 3/8-4; 1 1/2-4	1 1/4-5; 1 3/8-4; 1 1/2-4
CTM2SC18C28-100-3L	28.5	(TR38-44)x7	1 3/4-4	-
CTM3SC20C33-120-3L	33.5	(TR46-52)x8	2-4; 2 1/4-3; 2 1/2-3; 2 3/4-3	2-4; 2 1/4-3; 2 1/2-3; 2 3/4-3

Thread Applications for Full Profile American Buttress Inserts

Toolholder	Thread Dia.	
D2	American Buttress	
CTM2SC20C26-105-3L-ABUT	26.4	(1.75"-4")-16; (1.75"-6")-12; (1.75"-6")-10; (1.75"-6")-8; (1.75"-6")-6

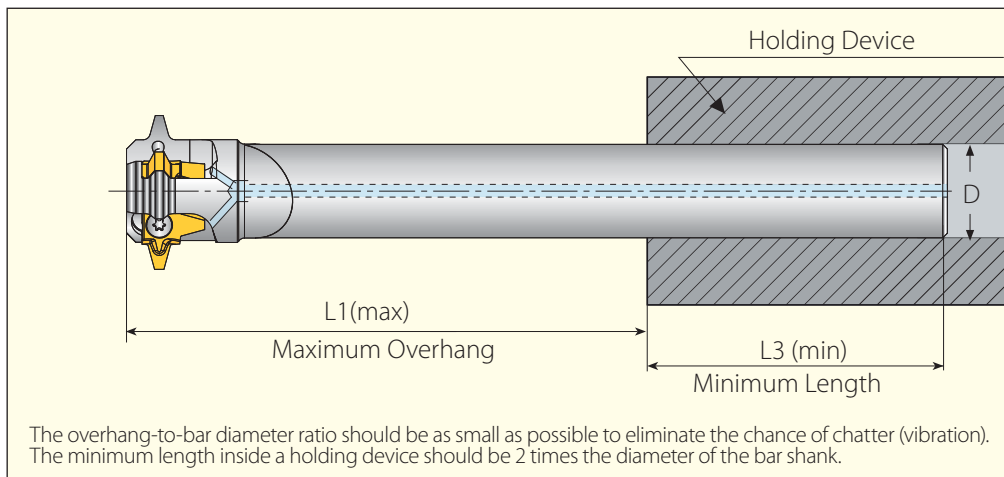

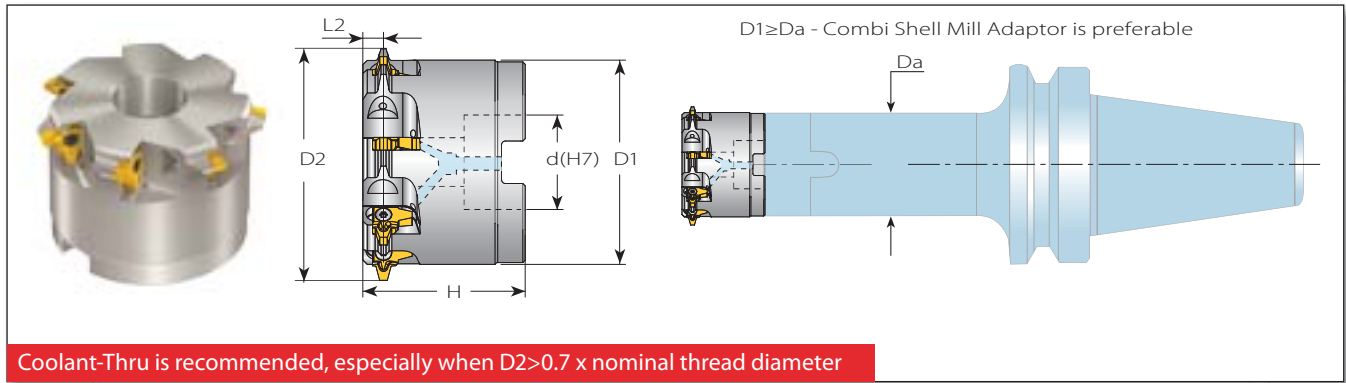

TMSD

Shell Mill (L Style - 3/8" L)



Shell Mill for 3/8" L Style Inserts

Spare Parts

Insert Size	Ordering Code	Dimensions mm					No. of Flutes			
IC	Toolholder	D1	D2	d(H7)	H	L2	Z	Insert Screw	Torx Key	Holder Screw
3/8" L	TM7SC-D80-32-3L	69.2	80	32	55	7.0	7	SA3T	HK3T	M16x2.0x40
	TM5SC-D48-22-3L-ABUT	41.0	48	22	40	4.7	5			M10x1.50x35
	TM6SC-D58-27-3L-ABUT	51.0	58	27			6			M12x1.75x40

TMSD

Shell Mill (L Style - 3/8" L) Applications

Thread Applications for Partial Profile Inserts

Toolholder	Min. Thread Dia.			
D2	Trapez	American ACME	Stub ACME	
TM7SC-D80-32-3L	80	(TR115-130)x6; (TR175-240)x8	-	-

Thread Applications for Full Profile American Buttress Inserts

Toolholder	Thread Dia.	
D2	American Buttress	
TM5SC-D48-22-3L-ABUT	48	(3.0"-6")-12; (3.0"-6")-10; (3.0"-6")-8; (3.0"-6")-6
TM6SC-D58-27-3L-ABUT	58	(4.0"-6")-12; (4.0"-6")-10; (4.0"-6")-8; (4.0"-6")-6

Shell Mill (5/8" V Style)

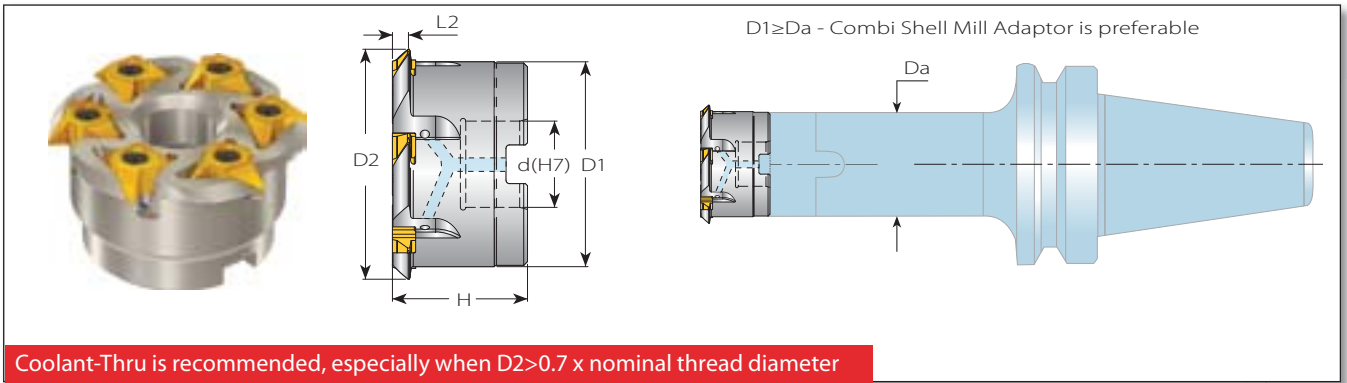

Shell Mill for 5/8" V Style Inserts

Insert Size	Ordering Code	Dimensions mm						No. of Flutes	Insert	Spare Parts		
		D1	D2	d(H7)	H	L2	Z			Insert Screw	Torx Key	Holder Screw
5/8" V	TM6SC-D88-32-5V6-ABUT	72.5	88	32	47.9	5.35	6	5VI4ABUT-TM...	SA5T	HK5T	M16x2.0x40	
	TM6SC-D88-32-5V8-ABUT	72.5	88	32	51.7	8.50		5VI2.5ABUT-TM...				
						50.0	7.10	6				5VI3ABUT-TM...

Shell Mill (5/8" V Style) Applications

Thread Applications for Full Profile American Buttress Inserts

Toolholder	D2	Thread Dia.
		American Buttress
TM6SC-D88-32-5V6-ABUT	88	(5.0"-24")-4
TM6SC-D88-32-5V8-ABUT	88	(6.0"-24")-3; (7.0"-24")-2.5

Standard Toolholders - Steel Cylindrical Shank (A Style)

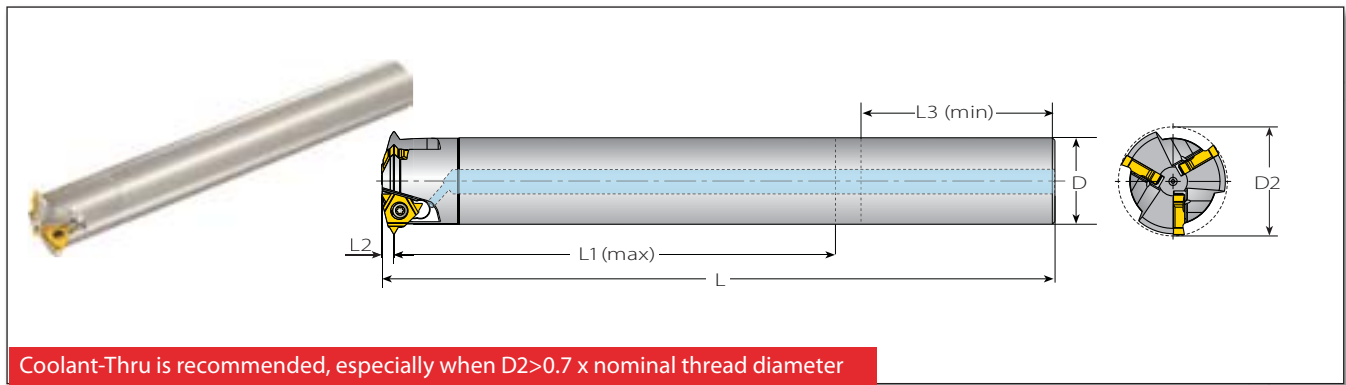

Steel Cylindrical Shank for A-Style Inserts

Steel Cylindrical Shank for A-Style Inserts									Spare Parts		
Insert Size	Ordering Code	Dimensions mm							No. of Flutes		
IC		L	L1 (max)	L2	L3 (min)	D	D2	Z	Insert Screw	Torx Key	
1/4"A	TM3SC20C26-105-2A	184	105	3.0	40	20	26.0	3	SN2T	HK2T	
3/8"A	TM3SC28C35-144-3A	218	144	4.0	46	28	35.3	3	SA3T	HK3T	

TMSD

Steel Cylindrical Shank (A Style) Applications

Thread Applications for Partial Profile Inserts

Toolholder	D2	Min. Thread Dia.				
		ISO Coarse	ISO Fine	UNC	UN/UNF/UNEF/UNS	BSP (G)
TM3SC20C26-105-2A	26	-	M28x1.5; M29x2.0; M30x2.5; M30x3.0	-	1 1/8"-16UN; 1 1/8"-14UNS; 1 3/16"-12UN; 1 1/4"-10UNS; 1 3/16"-8UN	-
TM3SC28C35-144-3A	35.3	-	M38x2.0; M39x2.5; M39x3.0; M40x4.0	-	1 9/16"-12UN; 1 5/8"-10UNS; 1 1/2"-8UN; 1 5/8"-6UN	-

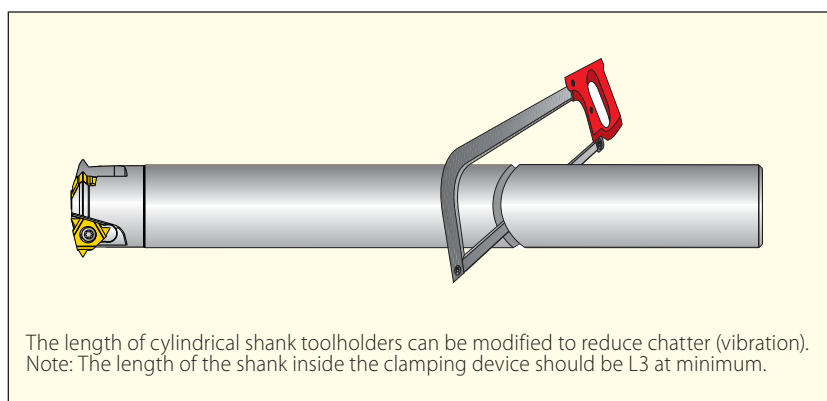

Recommended Grades, Cutting Speeds Vc [m/min] and Feed f [mm/tooth]

Material Group	Vardex No.	Material	Hardness Brinell HB	Vc [m/min]		Feed* f [mm/tooth] by Cutting Dia. (D2)			
				VBX	VTX	13-23	24-42	Shell Mill	
P Steel	1	Unalloyed Steel	Low Carbon (C=0.1-0.25%)	125	100-210	90-180	0.20-0.32	0.30-0.50	0.30-0.75
	2		Medium Carbon (C=0.25-0.55%)	150	100-180	90-170	0.20-0.32	0.30-0.50	0.30-0.75
	3		High Carbon (C=0.55-0.85%)	170	100-170	90-160	0.15-0.23	0.25-0.35	0.25-0.52
	4	Low Alloy Steel (alloying elements ≤5%)	Non Hardened	180	60-90	90-155	0.17-0.28	0.28-0.45	0.28-0.67
	5		Hardened	275	80-150	80-160	0.15-0.28	0.25-0.45	0.25-0.67
	6		Hardened	350	70-140	70-150	0.15-0.25	0.25-0.40	0.25-0.60
	7	High Alloy Steel (alloying elements >5%)	Annealed	200	60-130	70-115	0.15-0.22	0.20-0.30	0.20-0.45
	8		Hardened	325	70-110	60-100	0.13-0.21	0.18-0.30	0.18-0.45
	9	Cast Steel	Low Alloy (alloying elements <5%)	200	100-170	100-170	0.15-0.22	0.20-0.30	0.20-0.45
	10		High Alloy (alloying elements >5%)	225	70-120	70-130	0.12-0.22	0.17-0.30	0.17-0.45
M Stainless Steel	11	Stainless Steel Ferritic	Non Hardened	200	100-170	120-180	0.15-0.22	0.22-0.34	0.22-0.50
	12		Hardened	330	100-170	120-180	0.16-0.23	0.21-0.32	0.21-0.48
	13	Stainless Steel Austenitic	Austenitic	180	70-140	100-140	0.15-0.25	0.25-0.40	0.25-0.60
	14		Super Austenitic	200	70-140	100-140	0.12-0.20	0.17-0.26	0.17-0.39
	15	Stainless Steel Cast Ferritic	Non Hardened	200	70-140	100-140	0.16-0.24	0.25-0.37	0.25-0.55
	16		Hardened	330	70-140	100-140	0.12-0.20	0.17-0.26	0.17-0.39
	17	Stainless Steel Cast Austenitic	Austenitic	200	70-120	100-120	0.15-0.22	0.20-0.30	0.20-0.45
	18		Hardened	330	70-120	100-120	0.12-0.20	0.17-0.26	0.17-0.39
K Cast Iron	28	Malleable Cast Iron	Ferritic (short chips)	130	60-130	100-120	0.16-0.24	0.25-0.37	0.25-0.55
	29		Pearlitic (long chips)	230	60-120	80-100	0.15-0.22	0.20-0.30	0.20-0.45
	30	Grey Cast Iron	Low Tensile Strength	180	60-130	80-100	0.15-0.22	0.22-0.34	0.22-0.50
	31		High Tensile Strength	260	60-100	80-100	0.15-0.22	0.20-0.30	0.20-0.45
	32	Nodular Sg Iron	Ferritic	160	60-125	80-100	0.10-0.20	0.15-0.25	0.15-0.37
	33		Pearlitic	260	50-90	60-90	0.15-0.22	0.20-0.30	0.20-0.45
N Non-Ferrous Metals	34	Aluminium Alloys Wrought	Non Aging	60	100-250		0.30-0.50	0.60-1.00	0.60-1.50
	35		Aged	100	100-180		0.28-0.50	0.50-0.90	0.50-1.20
	36	Aluminium Alloys Cast	Cast	75	150-400		0.28-0.50	0.50-0.90	0.50-1.20
	37		Cast & Aged	90	150-280		0.25-0.40	0.40-0.60	0.40-0.90
	38	Aluminium Alloys Cast Si 13-22%	Cast Si 13-22%	130	80-150		0.28-0.50	0.50-0.90	0.50-1.20
	39	Copper and Copper Alloys	Brass	90	120-210	100-200	0.30-0.50	0.60-1.00	0.60-1.50
40	Bronze and Non Lead Copper		100	120-210	100-200	0.28-0.50	0.50-0.90	0.50-1.20	
S Heat Resistant Material	19	High Temperature Alloys	Annealed (iron based)	200	20-45	20-40	0.09-0.15	0.12-0.22	0.12-0.33
	20		Aged (iron based)	280	20-30	20-30	0.07-0.13	0.10-0.20	0.10-0.30
	21		Annealed (nickel or cobalt based)	250	15-20	15-20	0.08-0.15	0.08-0.20	0.08-0.30
	22		Aged (nickel or cobalt based)	350	10-15	10-15	0.08-0.15	0.08-0.20	0.08-0.30
	23	Titanium Alloys	Pure 99.5 Ti	400Rm	70-140	70-120	0.07-0.13	0.10-0.20	0.10-0.30
	24		α+β alloys	1050Rm	20-50	20-50	0.07-0.13	0.10-0.20	0.10-0.30
H Hardened Material	25	Extra Hard Steel	Hardened & Tempered	45-50HRC	15-45	15-45	0.05-0.12	0.05-0.18	0.05-0.27
	26			51-55HRC	15-40	15-40	0.05-0.12	0.05-0.18	0.05-0.27

* When using a Shell Mill toolholder, the feed can be increased by 50%.

* For 3/8"L it is recommended to machine in two passes and decrease the feed by 40%.

Grades

Grade	Application
VBX	TiCN coated carbide grade. Excellent grade for Steels and General Use.
VTX	TiAlN coated carbide grade. Ideal for Stainless Steels.





TM Solid

Solid Carbide Thread Milling Tools

Vardex Ordering Code System

■ TM Solid Carbide

HC		10	082	L15	-	I	1.50	ISO	TM		VTH
1	2	3	4	5		6	7	8	9	10	11

1 - Line	2 - No. of Teeth	3 - Shank Dia.	4 - Cutting Dia.	5 - Tool Cutting Length	6 - Type of Tool
HC - Helicool HCR - Helicool R HCC - Helicool C H - Helical S - Straight Flutes D - Deep Threading or MilliPro	1T - 1 Tooth 3T - 3 Teeth (MilliPro) 2L - 2 Teeth LH (MilliPro HD)	03 - 3.0 mm 04 - 4.0 06 - 6.0 08 - 8.0 10 - 10.0 12 - 12.0 14 - 14.0 16 - 16.0 18 - 18.0 20 - 20.0	0.7 - 19.9 mm	Up to 3Do	E - External I - Internal EI - External + Internal

7 - Pitch	8 - Standard	9 - System	10 - No. of Flutes	11 - Carbide Grade														
Full Profile - Pitch Range <table border="1"> <tr> <td>mm</td> <td>tpi</td> </tr> <tr> <td>0.25-6.0</td> <td>80 - 4.5</td> </tr> </table>	mm	tpi	0.25-6.0	80 - 4.5	60 - Partial Profile 60° ISO - ISO Metric UN - American UN UNC - UN Coarse UNF - UN Fine UNEF - UN Extra Fine UNJ - UNJ MJ - MJ BSW - Whitworth Coarse BSP - BSP BSF - Whitworth Fine BSPT - BSPT NPT - NPT ANPT - ANPT NPTF - NPTF NPS - NPS PG - PG TP60 - Taper 60° TP55 - Taper 55°	TM TML - Extra Long	3 - 3 Flutes 5 - 5 Flutes * For straight flutes only.	VTS VTH										
mm	tpi																	
0.25-6.0	80 - 4.5																	
Partial Profile - Pitch Range <table border="1"> <tr> <td></td> <td>mm</td> <td>tpi</td> </tr> <tr> <td>TA</td> <td>0.5-0.8</td> <td>32-56</td> </tr> <tr> <td>TB</td> <td>0.5-1.0</td> <td>24-56</td> </tr> <tr> <td>TC</td> <td>1.0-1.50</td> <td>16-24</td> </tr> <tr> <td>TD</td> <td>1.0-1.75</td> <td>14-24</td> </tr> <tr> <td>TF</td> <td>0.5-1.25</td> <td>20-48</td> </tr> </table>		mm	tpi	TA	0.5-0.8	32-56	TB	0.5-1.0	24-56	TC	1.0-1.50	16-24	TD	1.0-1.75	14-24	TF	0.5-1.25	20-48
	mm	tpi																
TA	0.5-0.8	32-56																
TB	0.5-1.0	24-56																
TC	1.0-1.50	16-24																
TD	1.0-1.75	14-24																
TF	0.5-1.25	20-48																

■ HTC Thriller

HTC	M6	1.0	2D	VTN
1	2	3	4	5

1 - Line	2 - Thread Diameter	3 - Pitch	4 - Thread Length	5 - Carbide Grade
HTC - Thriller	M6 - M12	1 - 1.75mm	2D 2.5D	VTN VTS

TM Solid Carbide Program



Miniature Threads MilliPro

MilliPro &
MilliPro EL
From M1.6x0.35 (1-72UNF)



MilliPro HD
Up to 62 HRc

MilliPro Dental
From M1.0x0.25 (0-80UNF)

Long Thread Deep Threading

Full Profile



Partial Profile

Up to 3XDo

Normal Use Straight Flutes

Taper
For Bone Plate Applications
From Pitch 0.3-0.6mm



From M4.5x0.75 (No.8-36UNF)

Heavy Duty Helicool



From M3x0.5 (No.10-32UNF)

Radial Coolant Helicool-R (HCR)



From M6x1.0

Helicool and Chamfer Helicool-C (HCC)



From M6x1.0

Economical Tool Helical

Taper
For Bone Plate Applications
From Pitch 0.3-0.6mm



From M3x0.5 (No.8-36UNF)

Drill, Thread and Chamfer HTC



From M6x1.0

TM Solid

Internal

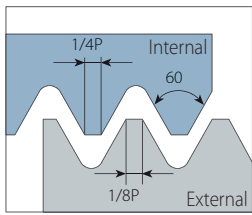

Defined by: R262 (DIN 13)
Tolerance class: 6H

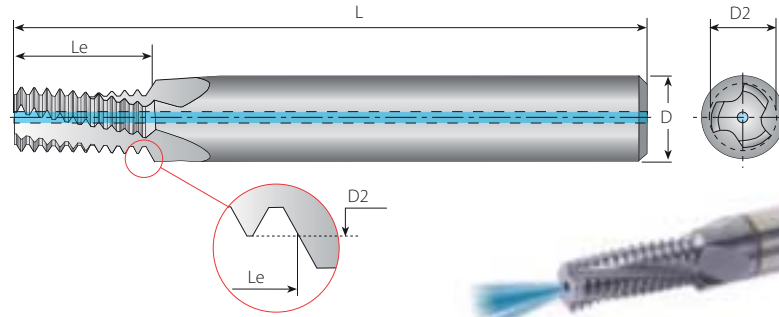

Helical Flutes with Thru-Hole Coolant

1.5 x Do (Le ≤ 1.5 x Thread Diameter)

Thread		Pitch	Ordering Code	Dimensions mm			No. of Flutes	Teeth	Bore Dia.*	
M Coarse	M Fine	mm	Internal	D	D2	L	Le	Z	Zt	mm
M3x0.5	M3.5-M16x0.5	0.5	HC04024L04-I0.50ISOTM...	4	2.40	45	4.7	3	9	2.5
M4x0.7		0.7	HC04031L06-I0.70ISOTM...	4	3.15	45	6.6	3	9	3.3
M5x0.8		0.8	HC04039L07-I0.80ISOTM...	4	3.90	45	7.6	3	9	4.2
M6x1.0	M8-M40x1.0	1.0	HC06048L09-I1.00ISOTM...	6	4.80	57	9.5	3	9	5.0
M8x1.25		1.25	HC08065L13-I1.25ISOTM...	8	6.50	61	13.1	3	10	6.8
M10x1.5	M12-M48x1.5	1.5	HC10082L15-I1.50ISOTM...	10	8.20	73	15.7	3	10	8.5
M12x1.75		1.75	HC10099L18-I1.75ISOTM...	10	9.90	73	18.4	4	10	10.2
M14x2.0	M17-M80x2.0	2.0	HC12116L21-I2.00ISOTM...	12	11.60	73	21.0	4	10	12.0
M16x2.0	M17-M80x2.0	2.0	HC14136L25-I2.00ISOTM...	14	13.60	92	25.0	4	12	14.0

Helical Flutes with Thru-Hole Coolant

2 x Do (Le ≤ 2 x Thread Diameter)

Thread		Pitch	Ordering Code	Dimensions mm			No. of Flutes	Teeth	Bore Dia.*	
M Coarse	M Fine	mm	Internal	D	D2	L	Le	Z	Zt	mm
M3x0.5	M3.5-M16x0.5	0.5	HC04024L06-I0.50ISOTM...	4	2.40	45	6.2	3	12	2.5
	M4x0.5	0.5	HC04032L08-I0.50ISOTM...	4	3.20	45	8.2	3	16	3.5
	M5x0.5	0.5	HC06042L10-I0.50ISOTM...	6	4.20	57	10.2	3	20	4.5
M4x0.7		0.7	HC04031L08-I0.70ISOTM...	4	3.15	45	8.7	3	12	3.3
	M6x0.75	0.75	HC06050L12-I0.75ISOTM...	6	5.00	57	12.4	3	16	5.3
M5x0.8		0.8	HC04039L10-I0.80ISOTM...	4	3.90	45	10.8	3	13	4.2
M6x1.0	M8-M40x1.0	1.0	HC06048L12-I1.00ISOTM...	6	4.80	57	12.5	3	12	5.0
	M8x1.0	1.0	HC08067L16-I1.00ISOTM...	8	6.70	61	16.5	3	16	7.0
	M10x1.0	1.0	HC10087L20-I1.00ISOTM...	10	8.70	73	20.5	3	20	9.0
	M12x1.0	1.0	HC12107L24-I1.00ISOTM...	12	10.70	73	24.5	4	24	11.0
M8x1.25		1.25	HC08065L16-I1.25ISOTM...	8	6.50	61	16.9	3	13	6.8
	M10x1.25	1.25	HC10085L20-I1.25ISOTM...	10	8.50	73	20.6	3	16	8.8
M10x1.5	M12-M48x1.5	1.5	HC10082L20-I1.50ISOTM...	10	8.20	73	20.2	3	13	8.5
	M12x1.5	1.5	HC10099L24-I1.50ISOTM...	10	9.90	73	24.7	4	16	10.5
	M14x1.5	1.5	HC12119L29-I1.50ISOTM...	12	11.90	80	29.2	4	19	12.5
	M16x1.5	1.5	HC14139L32-I1.50ISOTM...	14	13.90	92	32.2	4	21	14.5
M12x1.75		1.75	HC10099L25-I1.75ISOTM...	10	9.90	73	25.4	4	14	10.2
M14x2.0	M17-M80x2.0	2.0	HC12116L29-I2.00ISOTM...	12	11.60	80	29.0	4	14	12.0
M16x2.0	M17-M80x2.0	2.0	HC14136L33-I2.00ISOTM...	14	13.60	92	33.0	4	16	14.0
M18x2.5		2.5	HC16148L36-I2.50ISOTM...	16	14.80	92	36.2	4	14	15.5
M20x2.5		2.5	HC18171L41-I2.50ISOTM...	18	17.10	102	41.2	4	16	17.5
M24x3.0		3.0	HC20199L49-I3.00ISOTM...	20	19.90	102	49.5	4	16	21.0

*Bore diameter applies to smallest thread dia.

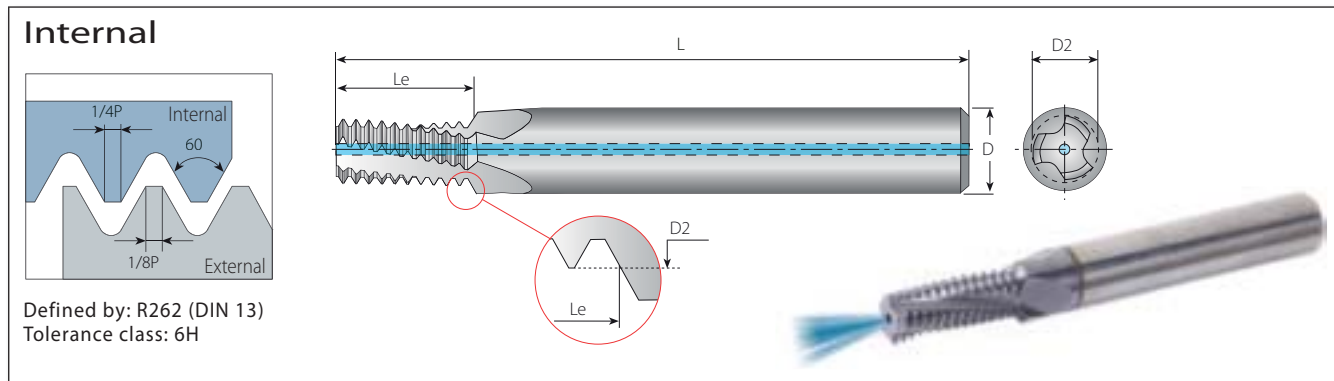

Helical Flutes with Thru-Hole Coolant

3 x Do (Le ≤ 1.5 x Thread Diameter)

Thread		Pitch	Ordering Code	Dimensions mm			No. of Flutes	Teeth	Bore Dia.*	
M Coarse	M Fine	mm	Internal	D	D2	L	Le**	Z	Zt	mm
M3x0.5	M3.5-M16x0.5	0.5	HC04024L09-I0.50ISOTM...	4	2.40	45	9.25	3	18	2.5
M4x0.7		0.7	HC04031L12-I0.70ISOTM...	4	3.15	47	12.95	3	18	3.3
M5x0.8		0.8	HC04039L15-I0.80ISOTM...	4	3.90	50	15.60	3	19	4.2
M6x1.0	M8-M40x1.0	1.0	HC06048L18-I1.00ISOTM...	6	4.80	60	18.50	3	18	5.0
M8x1.25		1.25	HC08065L25-I1.25ISOTM...	8	6.50	66	25.63	3	20	6.8
M10x1.5	M12-M48x1.5	1.5	HC10082L30-I1.50ISOTM...	10	8.20	75	30.75	3	20	8.5
M12x1.75		1.75	HC10099L36-I1.75ISOTM...	10	9.90	86	37.63	4	21	10.2
M16x2.0	M17-M80x2.0	2.0	HC14136L48-I2.00ISOTM...	14	13.60	108	49.00	4	24	14.0

* Bore diameter applies to smallest thread dia.

** Above solid carbide tools (Le=3xDo) are suitable for light machining only. Reduce feed by 30%.

Internal

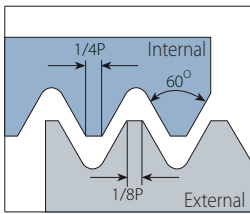

Defined by: ANSI B1.1:74
Tolerance class: 2B

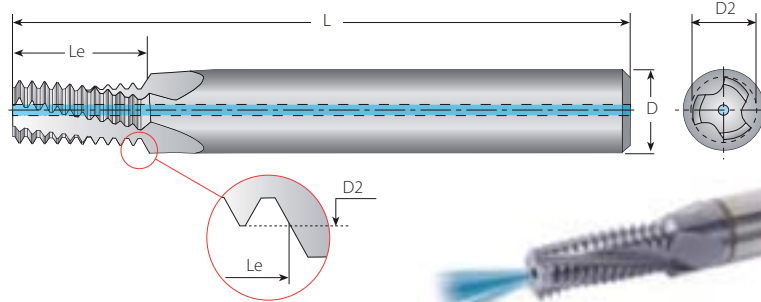

Helical Flutes with Thru-Hole Coolant

1.5 x Do (Le ≤ 1.5 x Thread Diameter)

Thread			Pitch	Ordering Code	Dimensions mm				No. of Flutes	Teeth	Bore Dia.*
UNC	UNF	UNEF	tpi	Internal	D	D2	L	Le	Z	Zt	mm
No.10-24	5/16", 3/8"x24	9/16"-11/16"x24	24	HC04035L07-I24UNCTM...	4	3.58	45	7.9	3	7	3.8
No.12-24	5/16", 3/8"x24	9/16"-11/16"x24	24	HC06041L08-I24UNCTM...	6	4.15	57	9.0	3	8	4.5
1/4"x20	7/16", 1/2"x20	3/4"-1"x20	20	HC06048L09-I20UNCTM...	6	4.88	57	9.5	3	7	5.2
5/16"x18	9/16", 5/8"x18	11/16"-1 11/16"x18	18	HC08061L11-I18UNCTM...	8	6.15	61	12.0	3	8	6.5
3/8"x16	3/4"x16		16	HC08076L15-I16UNCTM...	8	7.65	61	15.1	3	9	8.0
7/16"x14	7/8"x14		14	HC10090L17-I14UNCTM...	10	9.00	73	17.2	3	9	9.3
1/2"x13			13	HC12104L20-I13UNCTM...	12	10.35	73	20.5	4	10	10.8
9/16"x12	1"-1 1/2"x12		12	HC12118L22-I12UNCTM...	12	11.80	73	22.2	4	10	12.3

Helical Flutes with Thru-Hole Coolant

2 x Do (Le ≤ 2 x Thread Diameter)

Thread			Pitch	Ordering Code	Dimensions mm				No. of Flutes	Teeth	Bore Dia.*
UNC	UNF	UNEF	tpi	Internal	D	D2	L	Le	Z	Zt	mm
	No.10-32	No.12-3/8"x32	32	HC04038L09-I32UNFTM...	4	3.80	45	9.9	3	12	4.0
		No.12-3/8"x32	32	HC06044L11-I32UNEFTM...	6	4.40	57	11.5	3	14	4.7
	No.12, 1/4"x28	7/16", 1/2"x28	28	HC06043L11-I28UNFTM...	6	4.30	57	11.3	3	12	4.6
	1/4"x28	7/16", 1/2"x28	28	HC06052L13-I28UNFTM...	6	5.15	57	13.1	3	14	5.5
		7/16", 1/2"x28	28	HC10099L22-I28UNEFTM...	10	9.90	73	22.2	3	24	10.2
No.10-24	5/16", 3/8"x24	9/16"-11/16"x24	24	HC04035L10-I24UNCTM...	4	3.58	45	10.0	3	9	3.8
No.12-24	5/16", 3/8"x24	9/16"-11/16"x24	24	HC06041L11-I24UNCTM...	6	4.15	57	11.1	3	10	4.5
	5/16", 3/8"x24	9/16"-11/16"x24	24	HC08066L16-I24UNFTM...	8	6.68	61	16.4	3	15	6.8
	3/8"x24	9/16"-11/16"x24	24	HC10082L19-I24UNFTM...	10	8.20	73	19.6	3	18	8.5
		9/16"-11/16"x24	24	HC14129L29-I24UNEFTM...	14	12.90	92	29.1	4	27	13.2
	1/4"x20	7/16", 1/2"x20	20	HC06048L13-I20UNCTM...	6	4.88	57	13.3	3	10	5.2
	7/16", 1/2"x20	3/4"-1"x20	20	HC10096L22-I20UNFTM...	10	9.60	73	22.2	3	17	9.8
	1/2"x20	3/4"-1"x20	20	HC12111L26-I20UNFTM...	12	11.10	80	26.0	4	20	11.5
		3/4"-1"x20	20	HC18174L38-I20UNEFTM...	18	17.40	102	38.7	4	30	17.8
	5/16"x18	9/16", 5/8"x18	18	HC08061L16-I18UNCTM...	8	6.15	61	16.2	3	11	6.5
	9/16", 5/8"x18	11/16"-1 11/16"x18	18	HC14125L28-I18UNFTM...	14	12.50	92	28.9	4	20	12.8
	5/8"x18	11/16"-1 11/16"x18	18	HC16141L31-I18UNFTM...	16	14.10	92	31.7	4	22	14.5
	3/8"x16	3/4"x16	16	HC08076L19-I16UNCTM...	8	7.65	61	19.8	3	12	8.0
	3/4"x16		16	HC18170L38-I16UNFTM...	18	17.00	102	38.8	4	24	17.5
	7/16"x14	7/8"x14	14	HC10090L22-I14UNCTM...	10	9.00	73	22.7	3	12	9.3
	7/8"x14		14	HC20199L44-I14UNFTM...	20	19.90	102	44.4	4	24	20.5
	1/2"x13		13	HC12104L26-I13UNCTM...	12	10.35	80	26.4	4	13	10.8
	9/16"x12	1"-1 1/2"x12	12	HC12118L28-I12UNCTM...	12	11.80	80	28.6	4	13	12.3
	1"-1 1/2"x12		12	HC20199L51-I12UNFTM...	20	19.90	102	51.9	4	24	23.5
	5/8"x11		11	HC14131L33-I11UNCTM...	14	13.10	92	33.5	4	14	13.5
	3/4"x10		10	HC16159L39-I10UNCTM...	16	15.90	92	39.4	4	15	16.5
	7/8"x9		9	HC20190L46-I9UNCTM...	20	19.00	102	46.6	4	16	19.5
	1"x8		8	HC20199L52-I8UNCTM...	20	19.90	102	52.4	4	16	22.0

* Bore diameter applies to smallest thread dia.

Whitworth

Helicool

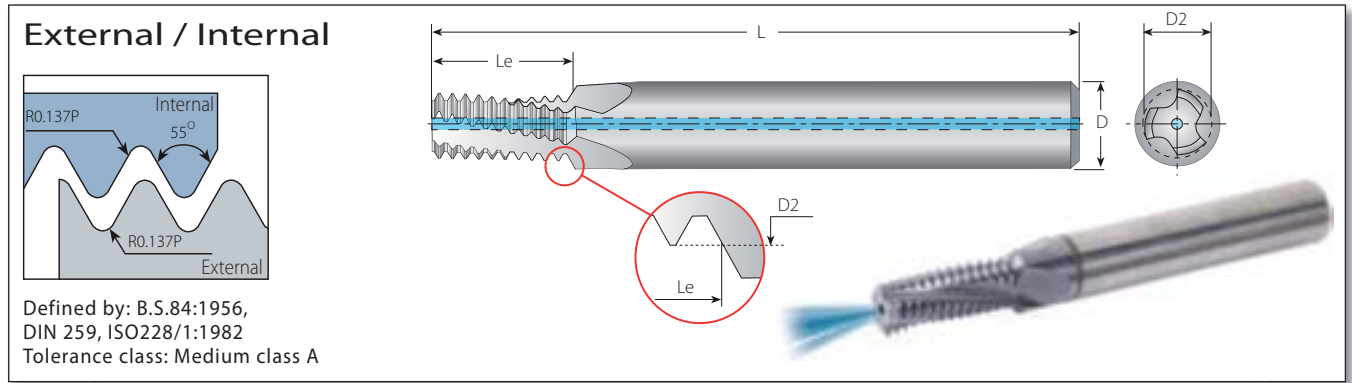

Helical Flutes with Thru-Hole Coolant

2 x Do (Le ≤ 2 x Thread Diameter)

Thread		Pitch	Ordering Code	Dimensions mm				No. of Flutes	Teeth	Bore Dia.*
BSW	BSF	tpi	External / Internal	D	D2	L	Le	Z	Zt	mm
	1/4"x26	26	HC06050L13-EI26BSFTM...	6	5.00	57	13.2	3	13	5.3
	5/16"x22	22	HC08063L16-EI22BSFTM...	8	6.35	61	16.7	3	14	6.7
1/4"x20	3/8"x20	20	HC06044L13-EI20BSWTM...	6	4.45	57	13.3	3	10	5.0
	3/8"x20	20	HC08076L19-EI20BSFTM...	8	7.65	61	19.7	3	15	8.2
5/16"x18	7/16"x18	18	HC06058L16-EI18BSWTM...	6	5.85	57	16.2	3	11	6.5
	7/16"x18	18	HC10092L23-EI18BSFTM...	10	9.20	73	23.3	3	16	9.7
3/8"x16	1/2", 9/16"x16	16	HC08072L19-EI16BSWTM...	8	7.20	61	19.8	3	12	7.9
	1/2", 9/16"x16	16	HC12105L26-EI16BSFTM...	12	10.50	80	26.2	4	16	11.1
	9/16"x16	16	HC14122L29-EI16BSFTM...	14	12.15	92	29.4	4	18	12.6
7/16"x14	5/8", 11/16"x14	14	HC10085L22-EI14BSWTM...	10	8.50	73	22.7	3	12	9.2
	5/8", 11/16"x14	14	HC14134L31-EI14BSFTM...	14	13.40	92	31.7	4	17	14.0
	11/16"x14	14	HC16150L35-EI14BSFTM...	16	15.00	92	35.4	4	19	15.6
1/2"x12	3/4"x12	12	HC10096L26-EI12BSWTM...	10	9.65	73	26.5	3	12	10.5
9/16"x12	3/4"x12	12	HC12113L28-EI12BSWTM...	12	11.25	80	28.6	4	13	12.1
	3/4"x12	12	HC18162L39-EI12BSFTM...	18	16.20	102	39.2	4	18	16.8
5/8"x11	7/8"x11	11	HC14126L33-EI11BSWTM...	14	12.60	92	33.5	4	14	13.4
11/16"x11		11	HC16142L35-EI11BSWTM...	16	14.20	92	35.8	4	15	15.0

* Bore diameter applies to smallest thread dia.

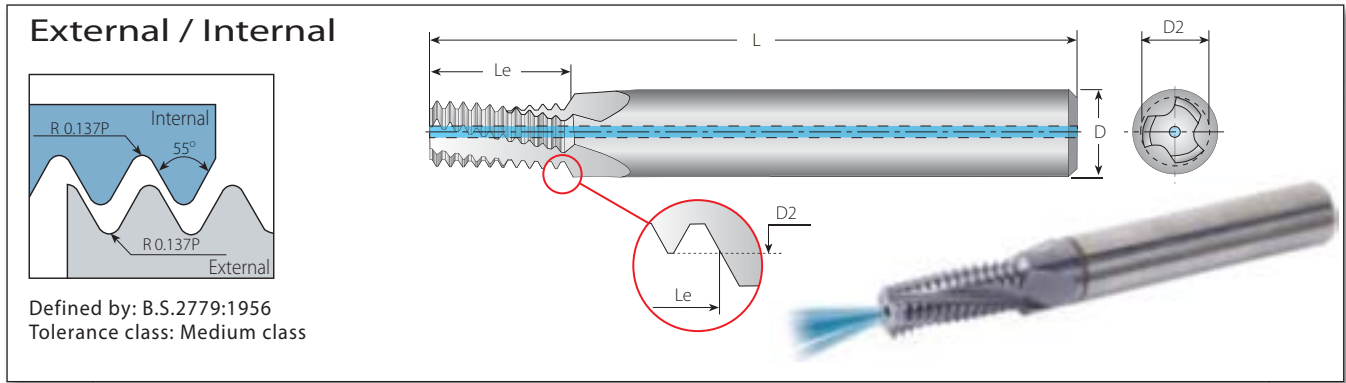

Helical Flutes with Thru-Hole Coolant

1.5 x Do (Le ≤ 1.5 x Thread Diameter)

Thread	Pitch	Ordering Code	Dimensions mm				No. of Flutes	Teeth	Bore Dia.*
Standard	tpi	External / Internal	D	D2	L	Le	Z	Zt	mm
1/16", 1/8"x28	28	HC08064L12-EI28BSPTM...	8	6.40	61	12.2	3	13	6.7
1/8"x28	28	HC10082L15-EI28BSPTM...	10	8.20	73	15.0	3	16	8.7
1/4", 3/8"x19	19	HC12110L20-EI19BSPTM...	12	11.00	80	20.7	4	15	11.8
3/8"x19	19	HC16145L26-EI19BSPTM...	16	14.50	92	26.1	4	19	15.2
1"-4"x11	11	HC20199L42-EI11BSPTM...	20	19.90	102	42.7	4	18	30.7

Helical Flutes with Thru-Hole Coolant

2 x Do (Le ≤ 2 x Thread Diameter)

Thread	Pitch	Ordering Code	Dimensions mm				No. of Flutes	Teeth	Bore Dia.*
Standard	tpi	External / Internal	D	D2	L	Le	Z	Zt	mm
1/16", 1/8"x28	28	HC08064L15-EI28BSPTM...	8	6.40	61	15.9	3	17	6.7
1/8"x28	28	HC10082L19-EI28BSPTM...	10	8.20	73	19.5	3	21	8.7
1/4", 3/8"x19	19	HC12110L27-EI19BSPTM...	12	11.00	80	27.4	4	20	11.8
3/8"x19	19	HC16145L34-EI19BSPTM...	16	14.50	92	34.1	4	25	15.2
1/2"-7/8"x14	14	HC18179L42-EI14BSPTM...	18	17.90	102	42.6	4	23	19.0

* Bore diameter applies to smallest thread dia.

NPT

Helicool

External / Internal

Defined by: USAS B2.1:1968
Tolerance class: Standard NPT

Helical Flutes with Thru-Hole Coolant

Thread	Pitch	Ordering Code	Dimensions mm				No. of Flutes	Teeth	Bore Dia.*	
			Standard	tpi	External / Internal	D				D2
1/16"x27	27	HC06059L09-EI27NPT-TM...		6	5.90	57	9.9	3	10	6.3
1/8"x27	27	HC08076L09-EI27NPT-TM...		8	7.65	61	9.9	3	10	8.5
1/4"x18	18	HC10099L14-EI18NPT-TM...		10	9.90	73	14.8	3	10	11.1
3/8"x18	18	HC12111L14-EI18NPT-TM...		12	11.15	73	14.8	4	10	14.5
1/2", 3/4"x14	14	HC16142L19-EI14NPT-TM...		16	14.25	92	19.0	4	10	17.7, 23.0
1", 1 1/4", 1 1/2", 2"x11.5	11.5	HC20196L23-EI11.5NPT-TM...		20	19.60	102	23.2	4	10	29.0, 37.7, 44.0, 56.0
2 1/2", 3"x8	8	HC20196L33-EI8NPT-TM...		20	19.60	102	33.3	4	10	66.5, 82.1

ANPT

Helicool

External / Internal

Defined by: MIL-P-7105B
Tolerance class: Standard ANPT

Helical Flutes with Thru-Hole Coolant

Thread	Pitch	Ordering Code	Dimensions mm				No. of Flutes	Teeth	Bore Dia.*	
			Standard	tpi	External / Internal	D				D2
1/4", 3/8"x18	18	HC10099L14-EI18ANPT-TM...		10	9.90	73	14.8	3	10	11.1 / 14.5
1/2", 3/4"x14	14	HC14139L18-EI14ANPT-TM...		14	13.90	92	19.0	4	10	17.7 / 23.0

* Bore diameter applies to smallest thread dia.

NPTF

Helicool

External / Internal

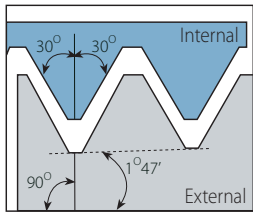

Defined by: ANSI 1.20.3-1976
Tolerance class: Standard NPTF

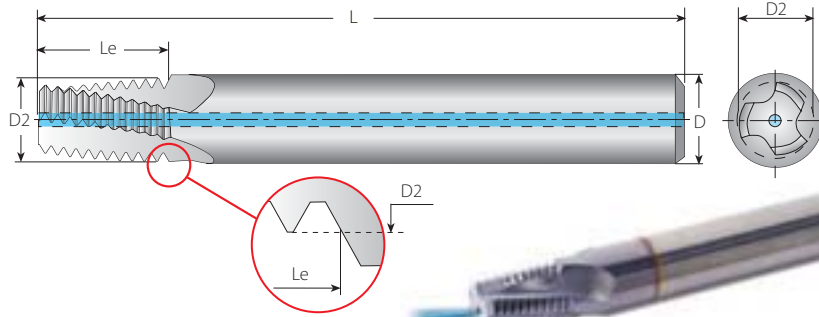

Helical Flutes with Thru-Hole Coolant

Thread	Pitch	Ordering Code	Dimensions mm				No. of Flutes	Teeth	Bore Dia.*
			D	D2	L	Le			
Standard	tpi	External / Internal	D	D2	L	Le	Z	Zt	mm
1/16"x27	27	HC06059L09-EI27NPTFTM...	6	5.90	57	9.9	3	10	6.3
1/8"x27	27	HC08076L09-EI27NPTFTM...	8	7.65	61	9.9	3	10	8.4
1/4"x18	18	HC10099L14-EI18NPTFTM...	10	9.90	73	14.8	3	10	11.1
3/8"x18	18	HC12111L14-EI18NPTFTM...	12	11.15	73	14.8	4	10	14.7
1/2", 3/4"x14	14	HC16142L19-EI14NPTFTM...	16	14.25	92	19.0	4	10	17.9, 23.4
1", 1 1/4", 1 1/2", 2"x11.5	11.5	HC20196L23-EI11.5NPTFTM...	20	19.60	102	23.2	4	10	29.0, 37.7, 43.7, 55.6
2 1/2", 3"x8	8	HC20196L33-EI8NPTFTM...	20	19.60	102	33.3	4	10	66.3, 82.1

BSPT

Helicool

External / Internal

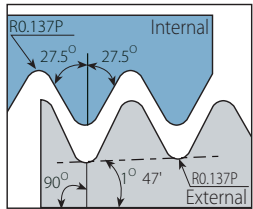

Defined by: B.S.21:1985
Tolerance class: Standard BSPT

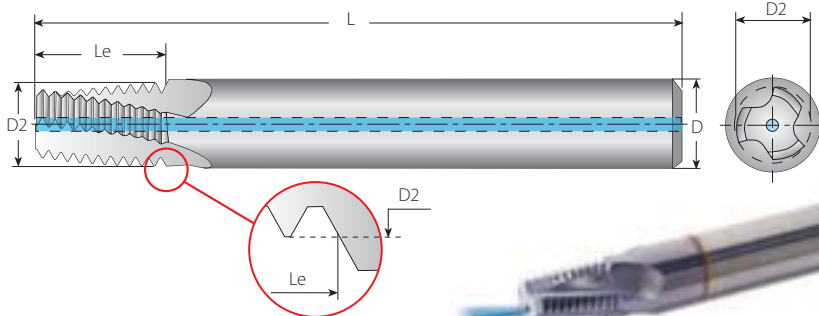

Helical Flutes with Thru-Hole Coolant

Thread	Pitch	Ordering Code	Dimensions mm				No. of Flutes	Teeth	Bore Dia.*
			D	D2	L	Le			
Standard	tpi	External / Internal	D	D2	L	Le	Z	Zt	mm
1/16"x28	28	HC06059L10-EI28BSPT-TM...	6	5.90	57	10.2	3	11	6.7
1/8"x28	28	HC08076L10-EI28BSPT-TM...	8	7.65	61	10.2	3	11	8.7
1/4"x19	19	HC10099L15-EI19BSPT-TM...	10	9.90	73	15.4	3	11	11.8
3/8"x19	19	HC12111L15-EI19BSPT-TM...	12	11.15	73	15.4	4	11	15.2
1/2", 3/4"x14	14	HC16142L22-EI14BSPT-TM...	16	14.25	92	22.7	4	12	19.0
1", 1 1/2", 2", 2 1/2"x11	11	HC20196L28-EI11BSPT-TM...	20	19.60	102	28.9	4	12	30.7

* Bore diameter applies to smallest thread dia.

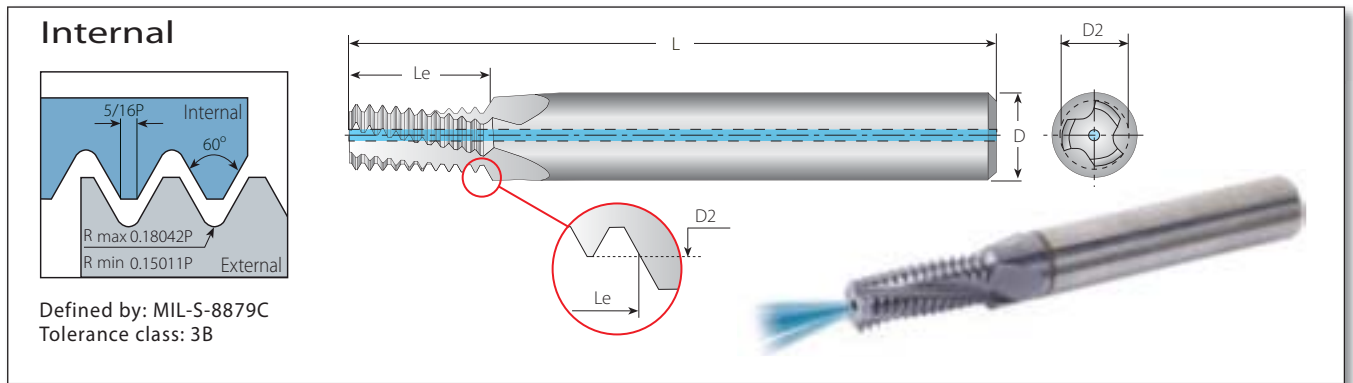

Helical Flutes with Thru-Hole Coolant

2 x Do (Le ≤ 2 x Thread Diameter)

Thread				Pitch	Ordering Code	Dimensions mm				No. of Flutes	Teeth	Bore Dia.*
UNJC	UNJF	UNJEF	UNJ	tpi	Internal	D	D2	L	Le	Z	Zt	mm
0.138" (#6)	0.190" (#10)	0.216" (#12)	0.4375" (7/16")	32	HC04027L07-I32UNJTM...	4	2.70	45	7.5	3	9	2.8
-	0.250" (1/4")	0.4375" (7/16")	0.5625" (9/16")	28	HC06054L13-I28UNJTM...	6	5.40	57	13.1	3	14	5.6
0.190" (#10)	0.3125" (5/16")	0.5625" (9/16")	-	24	HC04037L09-I24UNJTM...	4	3.70	45	10.0	3	9	4.0
-	0.3125" (5/16")	0.5625" (9/16")	-	24	HC08067L15-I24UNJTM...	8	6.70	61	16.4	3	15	7.0
0.250" (1/4")	0.4375" (7/16")	0.750" (3/4")	0.3125" (5/16")	20	HC06050L12-I20UNJTM...	6	5.00	57	13.3	3	10	5.3
-	0.4375" (7/16")	0.750" (3/4")	0.5625" (9/16")	20	HC10096L21-I20UNJTM...	10	9.60	73	22.2	4	17	10.0
0.3125" (5/16")	0.5625" (9/16")	1.0625" (1 1/16")	-	18	HC08064L15-I18UNJTM...	8	6.40	61	16.2	3	11	6.75
0.375" (3/8")	0.750" (3/4")	-	0.4375" (7/16")	16	HC08077L19-I16UNJTM...	8	7.70	61	19.8	3	12	8.1
0.4375" (7/16")	0.875" (7/8")	-	-	14	HC10092L21-I14UNJTM...	10	9.20	73	22.7	4	12	9.5
0.500" (1/2")	-	-	-	13	HC10099L25-I13UNJTM...	10	9.90	73	26.4	4	13	11.0

* Bore diameter applies to smallest thread dia.

NPS

Helicool

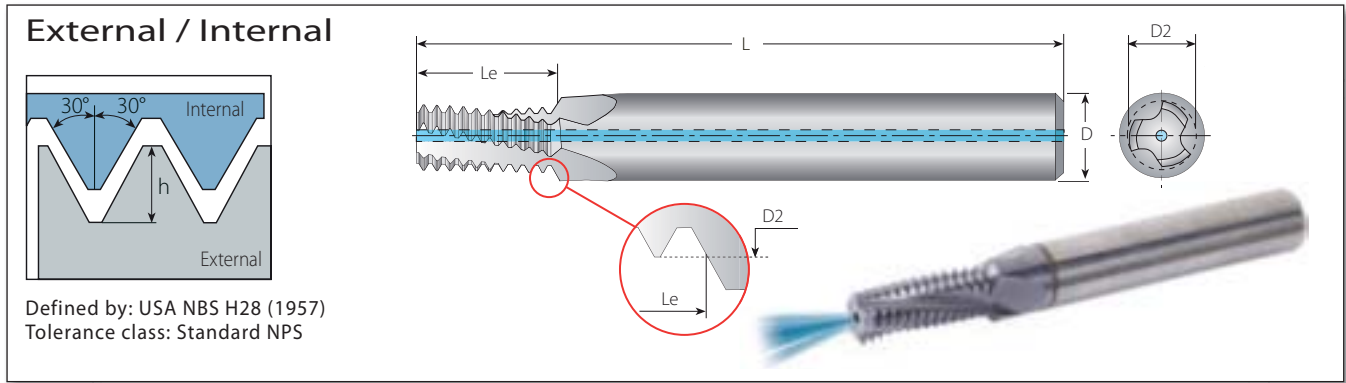

Helical Flutes with Thru-Hole Coolant

Thread	Pitch	Ordering Code	Dimensions mm				No. of Flutes	Teeth	Bore Dia.*
Standard	tpi	External / Internal	D	D2	L	Le	Z	Zt	mm
1/8"	27	HC08076L09-EI27NPSTM...	8	7.65	61	9.9	3	10	8.5
1/4"	18	HC10099L14-EI18NPSTM...	10	9.90	73	14.8	3	10	11.1
3/8"	18	HC12111L14-EI18NPSTM...	12	11.15	73	14.8	4	10	14.5
1/2", 3/4"	14	HC16142L18-EI14NPSTM...	16	14.25	92	19.0	4	10	17.7; 23.0
1", 2"	11.5	HC20196L22-EI11.5NPSTM...	20	19.60	102	23.2	4	10	29.0; 56.0

* Bore diameter applies to smallest thread dia.

ISO Metric

Helicool-R (HCR)

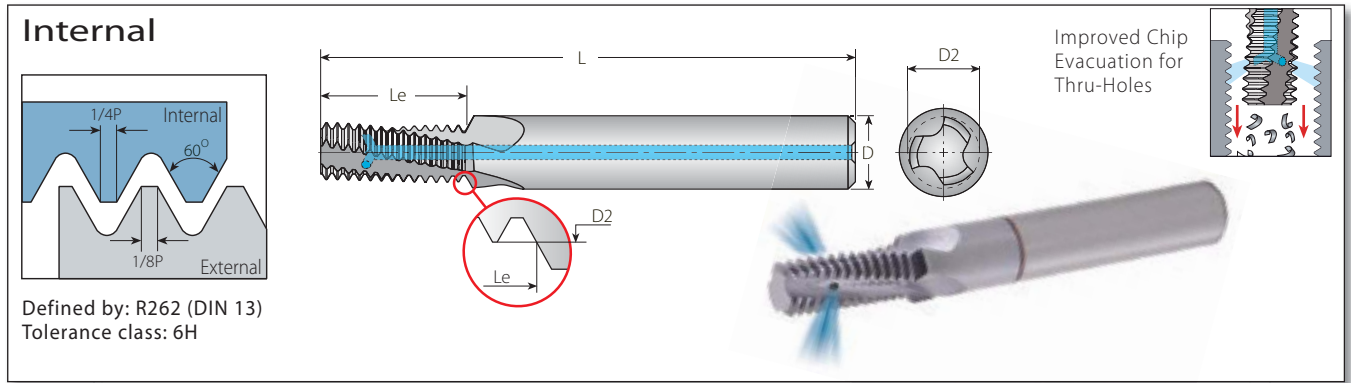

Helicool-R (HCR)

Helical Flutes with Radial Cooling

$2 \times D_o$ ($Le \leq 2 \times$ Thread Diameter)

Thread		Pitch	Ordering Code	Dimensions mm			Flutes	Teeth	Bore Dia.*	
M Coarse	M Fine	mm	Internal	D	D2	L	Le	Z	Zt	mm
M6x1.0	M8-M40x1.0	1.0	HCR06048L12-I1.00ISOTM...	6	4.8	57	12.5	3	12	5.0
	M10x1.0	1.0	HCR10087L20-I1.00ISOTM...	10	8.7	73	20.5	3	20	9.0
	M12x1.0	1.0	HCR12107L24-I1.00ISOTM...	12	10.7	73	24.5	4	24	11.0
M8x1.25		1.25	HCR08065L16-I1.25ISOTM...	8	6.5	64	16.9	3	13	6.8
M10x1.5	M12-M48x1.5	1.5	HCR10082L20-I1.50ISOTM...	10	8.2	73	20.3	3	13	8.5
	M12x1.5	1.5	HCR10099L24-I1.50ISOTM...	10	9.9	73	24.8	4	16	10.5
	M14x1.5	1.5	HCR12119L29-I1.50ISOTM...	12	11.9	84	29.3	4	19	12.5
	M16x1.5	1.5	HCR14139L32-I1.50ISOTM...	14	13.9	84	32.3	4	21	14.5
M12x1.75		1.75	HCR10099L25-I1.75ISOTM...	10	9.9	73	25.4	4	14	10.2

ISO Metric

Helicool-C (HCC)

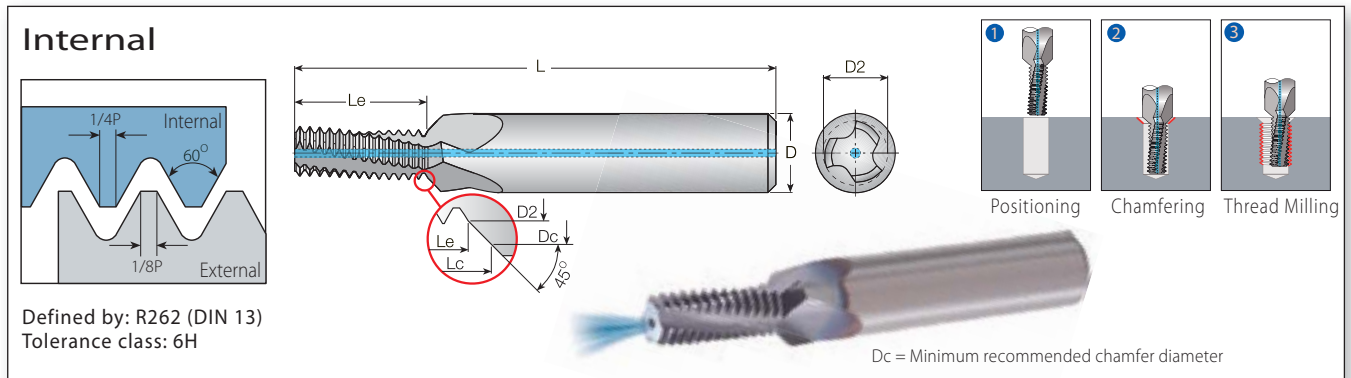

Helicool-C (HCC)

Helical Flutes with Axial Coolant - Thru & Chamfer

$2 \times D_o$ ($Le \leq 2 \times$ Thread Diameter)

Thread		Pitch	Ordering Code	Dimensions mm			No. of Flutes	Teeth	Bore Dia.*			
M Coarse	M Fine	mm	Internal	D	D2	Dc	L	Le	Lc	Z	Zt	mm
M6x1.0	M8-M40x1.0	1.0	HCC08048L12-I1.00ISOTM...	8	4.8	6.3	61	12.5	13.3	3	12	5.0
	M10x1.0	1.0	HCC12087L20-I1.00ISOTM...	12	8.7	10.3	73	20.5	21.3	3	20	9.0
	M12x1.0	1.0	HCC14107L24-I1.00ISOTM...	14	10.7	12.3	80	24.5	25.3	4	24	11.0
M8x1.25		1.25	HCC10065L16-I1.25ISOTM...	10	6.5	8.3	73	16.9	17.8	3	13	6.8
M10x1.5	M12-M48x1.5	1.5	HCC12082L20-I1.50ISOTM...	12	8.2	10.3	80	20.3	21.3	3	13	8.5
	M12x1.5	1.5	HCC14099L24-I1.50ISOTM...	14	9.9	12.3	80	24.8	26.0	4	16	10.5
	M14x1.5	1.5	HCC16119L29-I1.50ISOTM...	16	11.9	14.3	92	29.3	30.5	4	19	12.5
	M16x1.5	1.5	HCC18139L32-I1.50ISOTM...	18	13.9	16.3	92	32.3	33.5	4	21	14.5
M12x1.75		1.75	HCC14099L25-I1.75ISOTM...	14	9.9	12.3	80	25.4	26.6	4	14	10.2

* Bore diameter applies to smallest thread dia.

ISO Metric

HTC (Thriller)

Internal

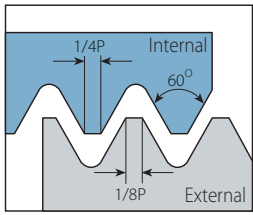

Defined by: R262 (DIN 13)
Tolerance class: 6H

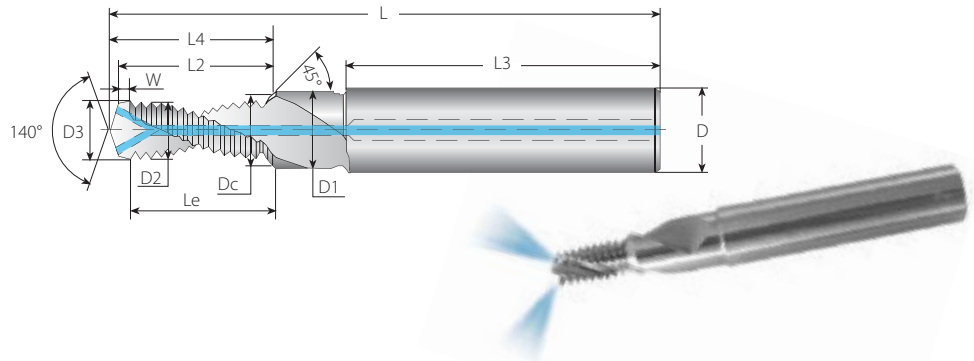

HTC (Thriller)

Drill, Chamfer & Thread with Coolant-Thru

Thread	Ordering Code	Pitch	Dimensions mm											No. of Flutes	Teeth		
			L	L4	L2	L3	W	Le	D3	D	D1	Dc	D2				
ISO 2xD Coarse	Internal	mm															
M6x1.0	HTC M6x1.0x2D...	1.00	62.0	14.5	13.7	36	1.0	12.7	5.0	8	6.6	6.3	4.85	2	11		
M8x1.25	HTC M8x1.25x2D...	1.25	74.0	18.2	17.1	40	1.3	15.8	6.8	10	9.0	8.3	6.45	2	11		
M10x1.5	HTC M10x1.5x2D...	1.50	79.0	23.4	22.1	45	1.5	20.6	8.5	12	11.0	10.3	8.08	2	12		
M12x1.75	HTC M12x1.75x2D...	1.75	89.0	27.1	25.5	45	1.5	24.0	10.3	14	13.5	12.3	9.74	2	12		
ISO 2.5xD Coarse																	
M6x1.0	HTC M6x1.0x2.5D...	1.00	62.0	16.5	15.7	36	1.0	14.7	5.0	8	6.6	6.3	4.85	2	13		
M8x1.25	HTC M8x1.25x2.5D...	1.25	74.0	23.2	22.1	40	1.3	20.8	6.8	10	9.0	8.3	6.45	2	15		
M10x1.5	HTC M10x1.5x2.5D...	1.50	79.0	27.9	26.6	45	1.5	25.1	8.5	12	11.0	10.3	8.08	2	15		

HTC - Thriller Operating Cycle

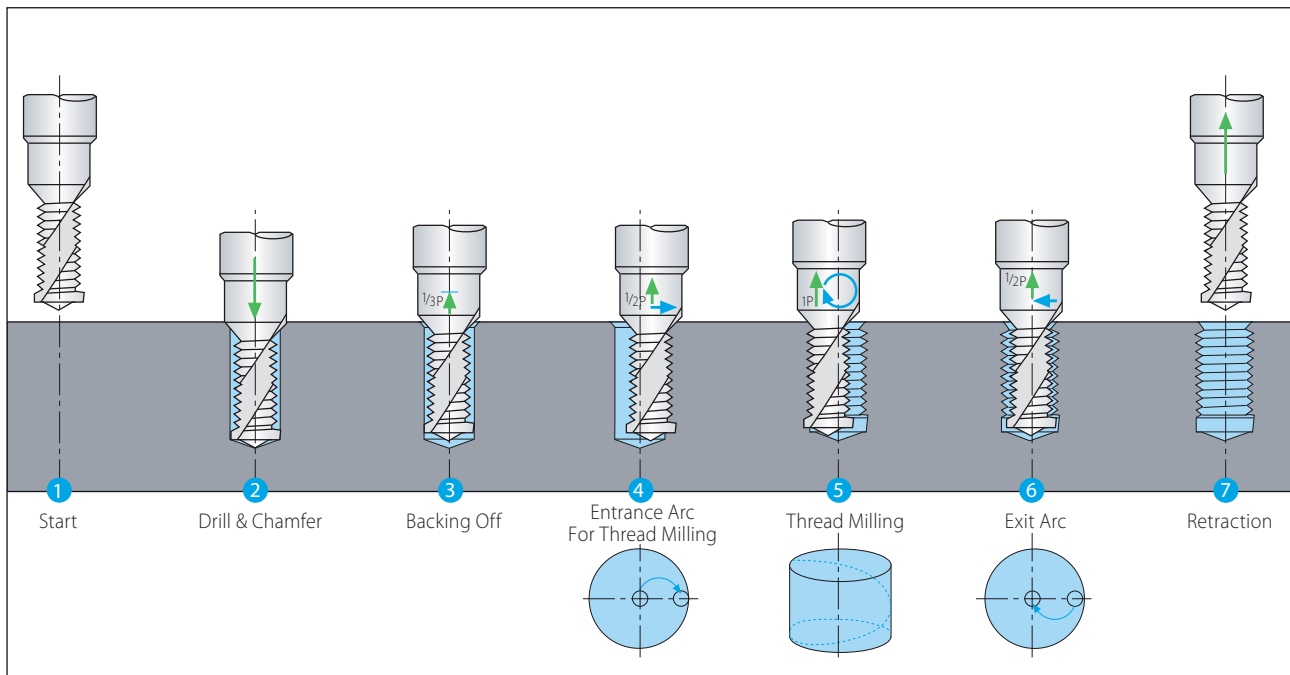

HTC line is suitable for Aluminium and Cast Iron machining only.

External / Internal

Defined by: R262 (DIN 13)
Tolerance class: 6g/6H

Helical Flutes - External

2 x Do (Le ≤ 2 x Thread Diameter)

Thread	Pitch	Ordering Code	Dimensions mm			No. of Flutes	Teeth	
M Coarse	mm	External	D	D2	L	Le	Z	Zt
M3x0.5	0.5	H04039L06-E0.5ISOTM...	4	3.9	45	6.0	3	12
M4.5x0.75	0.75	H04039L09-E0.75ISOTM...	4	3.9	45	9.0	3	12
M6x1.0	1.0	H04039L12-E1.0ISOTM...	4	3.9	45	12.0	3	12
M8x1.25	1.25	H06059L16-E1.25ISOTM...	6	5.9	57	16.25	3	13
M10x1.5	1.5	H08079L21-E1.5ISOTM...	8	7.9	63	21.0	3	14
M14x2.0	2.0	H10099L28-E2.0ISOTM...	10	9.9	73	28.0	4	14

Helical Flutes - Internal

2 x Do (Le ≤ 2 x Thread Diameter)

Thread	Pitch	Ordering Code	Dimensions mm			No. of Flutes	Teeth	Bore Dia.*		
M Coarse	M Fine	mm	Internal	D	D2	L	Le	Z	Zt	mm
M3x0.5	M3.5-M16x0.5	0.5	H04022L06-I0.5ISOTM...	4	2.2	45	6.0	3	12	2.5
	M4x0.5	0.5	H04030L08-I0.5ISOTM...	4	3.0	45	8.0	3	16	3.5
	M5x0.5	0.5	H04039L10-I0.5ISOTM...	4	3.9	45	10.0	3	20	4.5
M4x0.7		0.7	H04028L08-I0.7ISOTM...	4	2.8	45	8.4	3	12	3.3
	M6x0.75	0.75	H04039L12-I0.75ISOTM...	4	3.9	45	12.0	3	16	5.3
M5x0.8		0.8	H04035L10-I0.8ISOTM...	4	3.5	45	10.4	3	13	4.2
M6x1.0	M8-M40x1.0	1.0	H04039L12-I1.0ISOTM...	4	3.9	45	12.0	3	12	5.0
	M8x1.0	1.0	H06059L16-I1.0ISOTM...	6	5.9	57	16.0	3	16	7.0
	M10x1.0	1.0	H08079L20-I1.0ISOTM...	8	7.9	63	20.0	3	20	9.0
	M12x1.0	1.0	H10099L24-I1.0ISOTM...	10	9.9	73	24.0	4	24	11.0
M8x1.25		1.25	H06058L16-I1.25ISOTM...	6	5.8	57	16.25	3	13	6.8
	M10x1.25	1.25	H08077L20-I1.25ISOTM...	8	7.7	63	20.0	3	16	8.8
M10x1.5	M12-M48x1.5	1.5	H08077L21-I1.5ISOTM...	8	7.7	63	21.0	3	14	8.5
	M12x1.5	1.5	H10094L24-I1.5ISOTM...	10	9.4	73	24.0	4	16	10.5
	M14x1.5	1.5	H12112L28-I1.5ISOTM...	12	11.2	83	28.5	4	19	12.5
	M16x1.5	1.5	H12119L33-I1.5ISOTM...	12	11.9	83	33.0	4	22	14.5
M12x1.75		1.75	H10087L24-I1.75ISOTM...	10	8.7	73	24.5	4	14	10.2
M14x2.0	M17-M80x2.0	2.0	H10099L28-I2.0ISOTM...	10	9.9	73	28.0	4	14	12.0
M16x2.0	M17-M80x2.0	2.0	H12119L32-I2.0ISOTM...	12	11.9	83	32.0	4	16	14.0
M18-M22x2.5		2.5	H16139L40-I2.5ISOTM...	16	13.9	92	40.0	5	16	15.5
M24x3.0		3.0	H16159L42-I3.0ISOTM...	16	15.9	92	42.0	4	14	21.0

* Bore diameter applies to smallest thread dia.

External / Internal

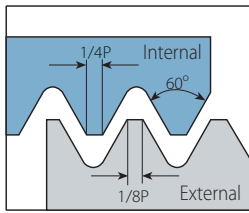

Defined by: ANSI B1.1.74
Tolerance class: 2A/2B



Helical Flutes - External

2 x Do (Le ≤ 2 x Thread Diameter)

Thread		Pitch	Ordering Code	Dimensions mm			No. of Flutes	Teeth	
UNC	UNF	tpi	External	D	D2	L	Le	Z	Zt
No.8-32		32	H04039L09-E32UNCTM...	4	3.9	45	8.7	3	11
	No.12-28	28	H04039L12-E28UNFTM...	4	3.9	45	11.8	3	13
No.12-24		24	H04039L13-E24UNCTM...	4	3.9	45	11.6	3	11
1/4"x20		20	H04039L13-E20UNCTM...	4	3.9	45	12.7	3	10
5/16"x18		18	H06059L17-E18UNCTM...	6	5.9	57	16.9	3	12
3/8"x16		16	H08079L19-E16UNCTM...	8	7.9	63	19.1	3	12
9/16"x12		12	H12119L30-E12UNCTM...	12	11.9	83	29.6	4	14

Helical Flutes - Internal

2 x Do (Le ≤ 2 x Thread Diameter)

Thread			Pitch	Ordering Code	Dimensions mm			No. of Flutes	Teeth	Bore Dia.*	
UNC	UNF	UNEF	tpi	Internal	D	D2	L	Le	Z	Zt	mm
No.8-36			36	H04030L09-I36UNFTM...	4	3.0	45	8.5	3	12	3.5
No.10-32	No.12-3/8"x32		32	H04033L11-I32UNFTM...	4	3.3	45	11.1	3	14	4.0
No.12-28, 1/4"x28	7/16", 1/2"x28		28	H04038L12-I28UNFTM...	4	3.8	45	11.8	3	13	4.6
1/4"x28	7/16", 1/2"x28		28	H06046L13-I28UNFTM...	6	4.6	57	12.7	3	14	5.5
	7/16", 1/2"x28		28	H10092L23-I28UNFTM...	10	9.2	73	22.7	4	25	10.2
No.10-24	5/16", 3/8"x24	9/16"-11/16"x24	24	H04029L11-I24UNCTM...	4	2.9	45	10.6	3	10	3.8
No.12-24	5/16", 3/8"x24	9/16"-11/16"x24	24	H04035L12-I24UNCTM...	4	3.5	45	11.6	3	11	4.5
	5/16", 3/8"x24	9/16"-11/16"x24	24	H06057L16-I24UNFTM...	6	5.7	57	15.9	3	15	6.8
	3/8"x24	9/16"-11/16"x24	24	H08074L19-I24UNFTM...	8	7.4	63	19.1	3	18	8.5
		9/16"-11/16"x24	24	H12119L29-I24UNFTM...	12	11.9	83	28.6	4	27	13.2
1/4"x20	7/16", 1/2"x20	3/4"-1"x20	20	H04039L13-I20UNCTM...	4	3.9	45	12.7	3	10	5.2
	7/16", 1/2"x20	3/4"-1"x20	20	H10085L23-I20UNFTM...	10	8.5	73	22.9	4	18	9.8
	1/2"x20	3/4"-1"x20	20	H10099L26-I20UNFTM...	10	9.9	73	25.4	4	20	11.5
		3/4"-1"x20	20	H16159L38-I20UNFTM...	16	15.9	92	38.1	5	30	17.8
5/16"x18	9/16", 5/8"x18	11/16"-1 11/16"x18	18	H06052L17-I18UNCTM...	6	5.2	57	16.9	3	12	6.5
	9/16", 5/8"x18	11/16"-1 11/16"x18	18	H12113L30-I18UNFTM...	12	11.3	83	29.6	4	21	12.8
	5/8"x18	11/16"-1 11/16"x18	18	H12119L33-I18UNFTM...	12	11.9	83	32.5	4	23	14.5
3/8"x16	3/4"x16		16	H08067L19-I16UNCTM...	8	6.7	63	19.1	3	12	8.0
	3/4"x16		16	H16159L38-I16UNFTM...	16	15.9	92	38.1	4	24	17.5
7/16"x14	7/8"x14		14	H08076L24-I14UNCTM...	8	7.6	63	23.6	4	13	9.3
	7/8"x14		14	H20187L44-I14UNFTM...	20	18.7	104	44.4	4	24	20.5
1/2"x13			13	H10089L26-I13UNCTM...	10	8.9	73	25.4	4	13	10.8
9/16"x12	1"-1 1/2"x12		12	H12103L30-I12UNCTM...	12	10.3	83	29.6	4	14	12.3
	1"-1 1/2"x12		12	H20199L51-I12UNFTM...	20	19.9	104	50.8	5	24	23.5
5/8"x11			11	H12110L32-I11UNCTM...	12	11.0	83	32.3	4	14	13.5
3/4"x10			10	H16135L38-I10UNCTM...	16	13.5	92	38.1	5	15	16.5
7/8"x9			9	H16152L45-I9UNCTM...	16	15.2	92	45.2	4	16	19.5
1"x8			8	H20170L51-I8UNCTM...	20	17.0	104	50.8	4	16	22.0

* Bore diameter applies to smallest thread dia.

BSP (G)

Helical

External / Internal

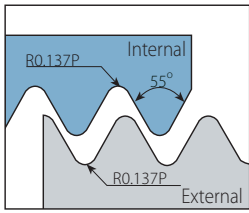

Defined by: B.S.2779:1956
Tolerance class: Medium class



Helical Flutes

2 x Do (Le ≤ 2 x Thread Diameter)

Thread	Pitch	Ordering Code	Dimensions mm				No. of Flutes	Teeth	Bore Dia.*
			D	D2	L	Le			
Standard	tpi	External / Internal	D	D2	L	Le	Z	Zt	mm
1/16"x28, 1/8"x28	28	H06058L16-EI28BSPTM...	6	5.8	57	16.3	3	18	6.7
1/8"x28	28	H08077L20-EI28BSPTM...	8	7.7	63	20.0	3	22	8.7
1/4"x19, 3/8"x19	19	H10099L27-EI19BSPTM...	10	9.9	73	26.7	4	20	11.8
3/8"x19	19	H16134L33-EI19BSPTM...	16	13.4	92	33.4	4	25	15.2
1/2", 3/4"x14	14	H16157L44-EI14BSPTM...	16	15.7	92	43.5	5	24	19.0
1", 1 1/2", 2", 2 1/2"x11	11	H20199L42-EI11BSPTM...	20	19.9	104	41.6	5	18	30.7

BSPT

Helical

External / Internal

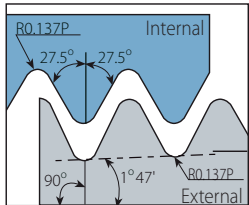

Defined by: B.S.21:1985
Tolerance class: Standard BSPT



Helical Flutes

Thread	Pitch	Ordering Code	Dimensions mm				No. of Flutes	Teeth	Bore Dia.*
			D	D2	L	Le			
Standard	tpi	External / Internal	D	D2	L	Le	Z	Zt	mm
1/16"x28	28	H06058L16-EI28BSPT-TM...	6	5.8	57	16.3	3	18	6.7
1/8"x28	28	H08077L20-EI28BSPT-TM...	8	7.7	63	20.0	3	22	8.7
1/4"x19	19	H10099L27-EI19BSPT-TM...	10	9.9	73	26.7	4	20	11.8
3/8"x19	19	H16134L33-EI19BSPT-TM...	16	13.4	92	33.4	4	25	15.2
1/2", 3/4"x14	14	H16157L44-EI14BSPT-TM...	16	15.7	92	43.5	5	24	19.0
1", 1 1/2", 2", 2 1/2"x11	11	H20199L42-EI11BSPT-TM...	20	19.9	104	41.6	5	18	30.7

* Bore diameter applies to smallest thread dia.

NPT

Helical

External / Internal

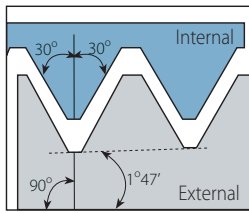

Defined by: USAS B2.1:1968
Tolerance class: Standard NPT

Helical Flutes

Thread	Pitch	Ordering Code	Dimensions mm				No. of Flutes	Teeth	Bore Dia.*
Standard	tpi	External / Internal	D	D2	L	Le	Z	Zt	mm
1/16"x27	27	H06053L09-EI27NPT-TM...	6	5.3	57	9.4	3	10	6.3
1/8"x27	27	H08075L09-EI27NPT-TM...	8	7.5	63	9.4	4	10	8.5
1/4"x18	18	H10094L14-EI18NPT-TM...	10	9.4	73	14.1	4	10	11.1
3/8"x18	18	H12119L14-EI18NPT-TM...	12	11.9	83	14.1	4	10	14.5
1/2", 3/4"x14	14	H16155L25-EI14NPT-TM...	16	15.5	92	25.4	5	14	17.7, 23.0
1"-2"x11.5	11.5	H20199L33-EI11.5NPT-TM...	20	19.9	104	33.1	5	15	29.0-56.0
2 1/2", 3"x8	8	H20199L38-EI8NPT-TM...	20	19.9	104	38.1	4	12	66.5

NPTF

Helical

External / Internal

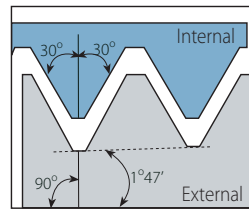

Defined by: ANSI 1.20.3-1976
Tolerance class: Standard NPTF

Helical Flutes

Thread	Pitch	Ordering Code	Dimensions mm				No. of Flutes	Teeth	Bore Dia.*
Standard	tpi	External / Internal	D	D2	L	Le	Z	Zt	mm
1/16"x27	27	H06053L09-EI27NPTFTM...	6	5.3	57	9.4	3	10	6.3
1/8"x27	27	H08075L09-EI27NPTFTM...	8	7.5	63	9.4	4	10	8.4
1/4"x18	18	H10094L14-EI18NPTFTM...	10	9.4	73	14.1	4	10	11.1
3/8"x18	18	H12119L14-EI18NPTFTM...	12	11.9	83	14.1	4	10	14.7
1/2", 3/4"x14	14	H16155L25-EI14NPTFTM...	16	15.5	92	25.4	5	14	17.9, 23.4
1"-2"x11.5	11.5	H20199L33-EI11.5NPTFTM...	20	19.9	104	33.1	5	15	29.4-56.2
2 1/2", 3"x8	8	H20199L38-EI8NPTFTM...	20	19.9	104	38.1	4	12	67.0

* Bore diameter applies to smallest thread dia.

Tap 60°, Tap 55°

Helical

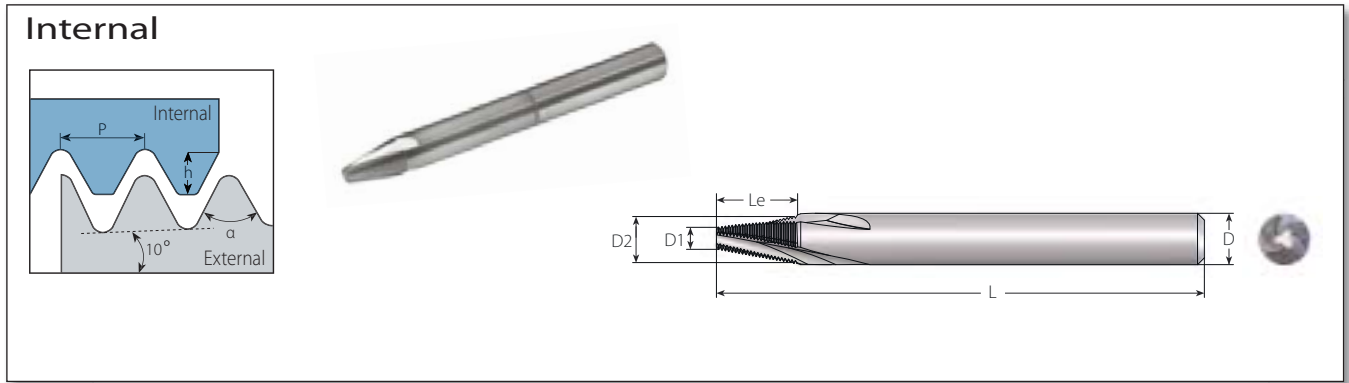

Helical Flutes - Taper 60°

TM Solid Helical Flutes for Bone Plate Applications

Pitch	Ordering Code	Taper	Thread Angle	Profile Height	Dimensions mm					No. of Flutes	Teeth
mm	Internal		α	h	D	D2	D1	L	Le	Z	Zt
0.4	H06059L080-I0.4TAP60TM...	20°	60°	0.20	6	5.9	3.2	57	8.0	3	20
0.5	H06059L090-I0.5TAP60TM...	20°	60°	0.25	6	5.9	2.9	57	9.0	3	18

Helical Flutes - Taper 55°

TM Solid Helical Flutes for Bone Plate Applications

Pitch	Ordering Code	Taper	Thread Angle	Profile Height	Dimensions mm					No. of Flutes	Teeth
mm	Internal		α	h	D	D2	D1	L	Le	Z	Zt
0.3	H03028L039-I0.3TAP55TM...	20°	55°	0.18	3	2.8	1.5	38	3.9	3	13
0.35	H04039L063-I0.35TAP55TM...	20°	55°	0.20	4	3.9	1.8	45	6.3	3	18
0.4	H06059L100-I0.4TAP55TM...	20°	55°	0.29	6	5.9	2.5	57	10.0	3	25
0.5	H06059L090-I0.5TAP55TM...	20°	55°	0.33	6	5.9	2.9	57	9.0	3	18
0.6	H06059L066-I0.6TAP55TM...	20°	55°	0.47	6	5.9	3.8	57	6.6	3	11

ISO Metric

Deep Threading

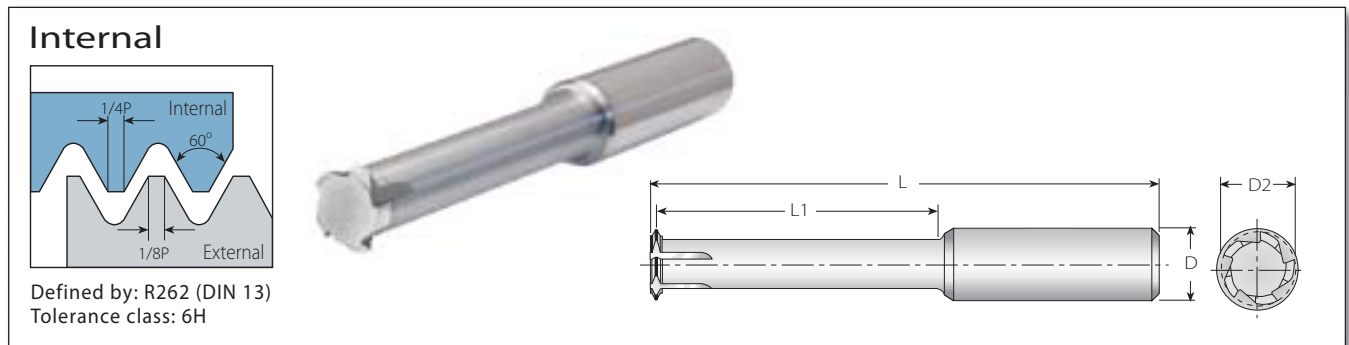

Deep Threading - Long Tools for Deep Holes

3 x Do (L1 ≤ 3 x Thread Diameter)

Thread	Pitch	Ordering Code	Dimensions mm				No. of Flutes	Teeth	Bore Dia.
M Coarse	mm	Internal	D	D2	L	L1	Z	Zt	mm
M6x1	1.0	D1T08041-I1.0ISOTM...	8	4.1	63	19	3	1	5.0
M8x1.25	1.25	D1T10058-I1.25ISOTM...	10	5.8	73	26	3	1	6.8
M10x1.5	1.50	D1T10077-I1.50ISOTM...	10	7.7	73	32	3	1	8.5
M12x1.5	1.50	D1T12094-I1.50ISOTM...	12	9.4	83	38	4	1	10.5
M12x1.75	1.75	D1T12087-I1.75ISOTM...	12	8.7	83	38	4	1	10.2
M14x2	2.0	D1T16102-I2.0ISOTM...	16	10.2	92	44	4	1	12.0
M16x2	2.0	D1T16122-I2.0ISOTM...	16	12.2	100	50	4	1	14.0
M18x2.5	2.50	D1T16129-I2.5ISOTM...	16	12.9	108	57	5	1	15.5
M20x2.5	2.50	D1T16148-I2.5ISOTM...	16	14.8	114	63	5	1	17.5

Partial Profile 60°

Deep Threading

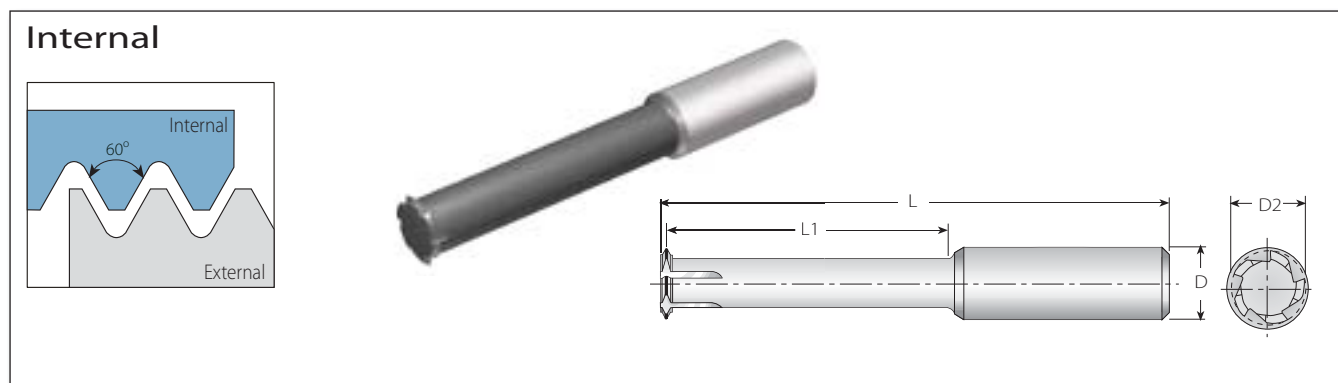

Deep Threading - Long Tools for Deep Holes

Min. Thread		Pitch		Ordering Code	Dimensions mm						
M Coarse	M Fine	UN, UNS, UNF, UNEF	mm	tpi	Internal	D	D2	L	L1	Z	Zt
M5x0.8	M5x0.5, M5X0.75	No.10-56UNS, No.10-48UNS, No.10-40UNS, No.10-36UNS, No.10-32UNF	0.5-0.8	32-56	D1T04390L160-ITA60TM...	4	3.90	45	16	4	1
M6x1.0	M6x0.5, M6X0.75	No.12-56UNS, No.12-48UNS, 1/4-40UNS, 1/4-36UNS, 1/4-32UNEF, 1/4-28UNF, 1/4-27UNS, 1/4-24UNS	0.5-1.0	24-56	D1T06485L200-ITB60TM...	6	4.85	51	20	5	1
M8x1.25	M7x0.5, M7x0.75, M7.5x1.0	5/16-48UNS, 5/16-40UNS, 5/16-36UNS, 5/16-32UNEF, 5/16-28UN, 5/16-27UNS, 5/16-24UNS, 5/16-20UN	0.5-1.25	20-48	D1T06590L250-ITF60TM...	6	5.90	64	25	5	1
-	M10.5x0.5, M11x0.75, M11x1.0	7/16-32UN, 7/16-28UNEF, 7/16-27UNS, 7/16-24UNS	0.5-1.0	24-56	D1T10990L350-ITB60TM...	10	9.90	73	35	6	1
M10x1.5	M10x1.0, M10X1.25	5/8-24UNF, 5/8-20UN, 7/16-18UNS, 7/16-16UN	1.0-1.50	16-24	D1T08790L320-ITC60TM...	8	7.90	63	32	6	1
M12x1.75	M12x1.0, M12X1.25, M12x1.5	1/2-24UNS, 1/2-20UNS, 1/2-18UNS, 1/2-16UNS, 1/2-14UNS	1.0-1.75	14-24	D1T10990L380-ITD60TM...	10	9.90	73	38	6	1
-	M13.5x1.0, M14x1.25, M14x1.5	5/8-24UNEF	1.0-1.75	14-24	D1T12119L450-ITD60TM...	12	11.90	83	45	6	1

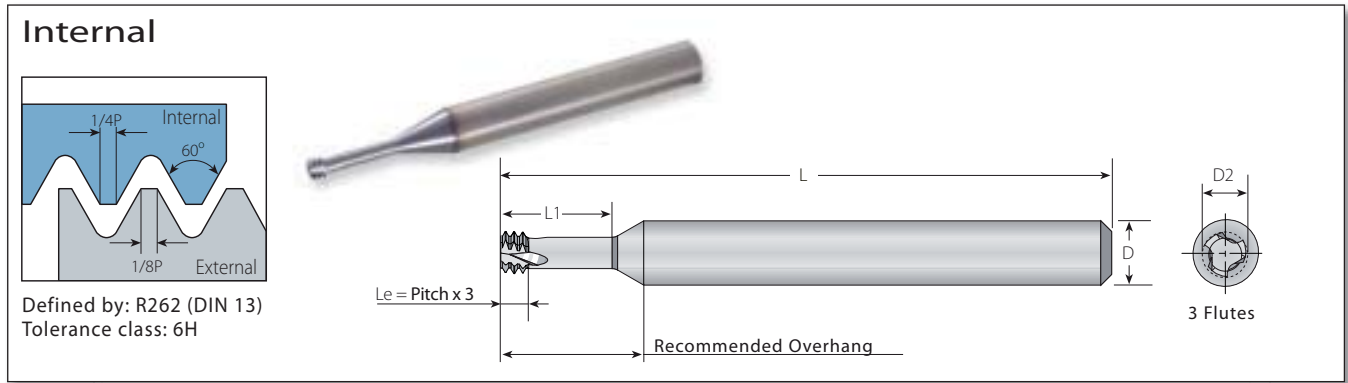

MilliPro
Miniature Thread Mills

2 x Do (L1 ≤ 2 x Thread Diameter)

Thread		Pitch	Ordering Code	Dimensions mm			No. of Flutes	Teeth	Bore Dia.*	
M Coarse	M Fine	mm	Internal	D	D2	L	L1	Z	Zt	mm
M1.6x0.35		0.35	D3T03012L034-I0.35ISOTM...	3	1.20	30	3.4	3	3	1.25
M2x0.4		0.4	D3T06015L042-I0.4ISOTM...	6	1.55	57	4.2	3	3	1.6
M2.2x0.45		0.45	D3T06016L046-I0.45ISOTM...	6	1.65	57	4.6	3	3	1.75
M2.5x0.45		0.45	D3T06019L052-I0.45ISOTM...	6	1.95	57	5.2	3	3	2.05
M3x0.5	M3.5-M16x0.5	0.5	D3T06024L062-I0.5ISOTM...	6	2.40	57	6.2	3	3	2.5
M3.5x0.6		0.6	D3T06027L073-I0.6ISOTM...	6	2.75	57	7.3	3	3	2.9
M4x0.7		0.7	D3T06031L083-I0.7ISOTM...	6	3.15	57	8.3	3	3	3.3
M5x0.8		0.8	D3T06040L104-I0.8ISOTM...	6	4.05	57	10.4	3	3	4.2
M6x1.0	M8-M40x1.0	1.0	D3T06048L125-I1.0ISOTM...	6	4.80	57	12.5	3	3	5.0
M8x1.25		1.25	D3T08065L166-I1.25ISOTM...	8	6.50	63	16.6	3	3	6.8
M10x1.5	M12-M48x1.50	1.50	D3T10082L208-I1.50ISOTM...	10	8.20	73	20.8	3	3	8.5
M12x1.75		1.75	D3T10099L250-I1.75ISOTM...	10	9.90	73	25.0	3	3	10.3
M16x2.0		2.0	D3T12119L330-I2.0ISOTM...	12	11.90	83	33.0	3	3	14.0
M20x2.5		2.50	D3T16159L413-I2.5ISOTM...	16	15.90	92	41.3	3	3	17.5

MilliPro
Miniature Thread Mills

3 x Do (L1 ≤ 3 x Thread Diameter)

Thread		Pitch	Ordering Code	Dimensions mm			No. of Flutes	Teeth	Bore Dia.*	
M Coarse	M Fine	mm	Internal	D	D2	L	L1	Z	Zt	mm
M1.6x0.35		0.35	D3T03012L050-I0.35ISOTM...	3	1.20	30	5.0	3	3	1.25
M2x0.4		0.4	D3T03015L062-I0.4ISOTM...	3	1.55	30	6.2	3	3	1.6
M2x0.4		0.4	D3T06015L062-I0.4ISOTM...	6	1.55	57	6.2	3	3	1.6
M2.5x0.45		0.45	D3T03019L077-I0.45ISOTM...	3	1.95	30	7.7	3	3	2.05
M2.5x0.45		0.45	D3T06019L077-I0.45ISOTM...	6	1.95	57	7.7	3	3	2.05
M3x0.5	M3.5-M16x0.5	0.5	D3T03024L092-I0.5ISOTM...	3	2.40	30	9.2	3	3	2.5
M3x0.5	M3.5-M16x0.5	0.5	D3T06024L092-I0.5ISOTM...	6	2.40	57	9.2	3	3	2.5
M4x0.7		0.7	D3T06031L123-I0.7ISOTM...	6	3.15	57	12.3	3	3	3.3
M5x0.8		0.8	D3T06040L154-I0.8ISOTM...	6	4.05	57	15.4	3	3	4.2
M6x1.0	M8-M40x1.0	1.00	D3T06048L185-I1.0ISOTM...	6	4.80	57	18.5	3	3	5.0
M8x1.25		1.25	D3T08065L246-I1.25ISOTM...	8	6.50	63	24.6	3	3	6.8

* Bore diameter applies to smallest thread dia.

Internal

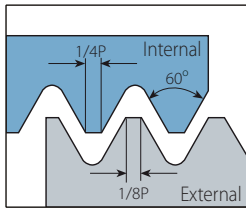

Defined by: ANSI B1.1:74
Tolerance class: 2B

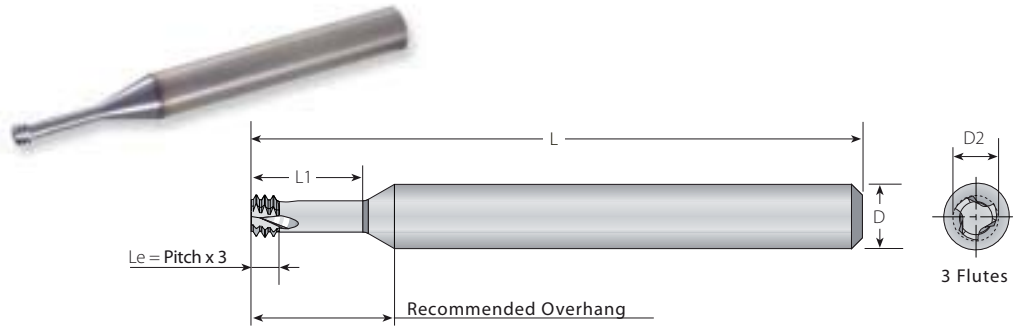

MilliPro

Miniature Thread Mills

2 x Do (L1 ≤ 2 x Thread Diameter)

Thread		Pitch	Ordering Code	Dimensions mm			No. of Flutes	Teeth	Bore Dia.*	
UNC	UNF	tpi	Internal	D	D2	L	L1	Z	Zt	mm
	No.1-72	72	D3T06014L039-I72UNTM...	6	1.45	57	3.9	3	3	1.6
No.1-64	No.2-64	64	D3T06014L042-I64UNTM...	6	1.40	57	4.2	3	3	1.5
No.2-56	No.3-56	56	D3T06016L050-I56UNTM...	6	1.65	57	5.0	3	3	1.8
No.3-48	No.4-48	48	D3T06019L060-I48UNTM...	6	1.90	57	6.0	3	3	2.1
No.4, No.5-40	No.6-40	40	D3T06021L060-I40UNTM...	6	2.10	57	6.0	3	3	2.3
No.5-40	No.6-40	40	D3T06024L072-I40UNTM...	6	2.45	57	7.2	3	3	2.6
	No.8-36	36	D3T06033L087-I36UNTM...	6	3.30	57	8.7	3	3	3.5
No.6, No.8-32	No.10-32	32	D3T06025L074-I32UNTM...	6	2.55	57	7.4	3	3	2.8
No.8-32	No.10-32	32	D3T06032L100-I32UNTM...	6	3.20	57	10.0	3	3	3.5
	No.10-32	32	D3T06038L103-I32UNTM...	6	3.80	57	10.3	3	3	4.0
	1/4"x28	28	D3T06052L132-I28UNTM...	6	5.25	57	13.2	3	3	5.5
No.10-24	5/16"x24	24	D3T06035L102-I24UNTM...	6	3.58	57	10.2	3	3	3.9
	5/16"x24	24	D3T08066L165-I24UNTM...	8	6.68	63	16.5	3	3	6.9
1/4"x20	7/16"x20	20	D3T06048L134-I20UNTM...	6	4.88	57	13.4	3	3	5.2
	7/16"x20	20	D3T10095L230-I20UNTM...	10	9.55	73	23.0	3	3	9.9
5/16"x18		18	D3T08061L169-I18UNTM...	8	6.15	63	16.9	3	3	6.6
3/8"x16		16	D3T08067L191-I16UNTM...	8	6.70	63	19.1	3	3	8.0
7/16"x14		14	D3T10090L233-I14UNTM...	10	9.00	73	23.3	3	3	9.4

MilliPro

Miniature Thread Mills

3 x Do (L1 ≤ 3 x Thread Diameter)

Thread		Pitch	Ordering Code	Dimensions mm			No. of Flutes	Teeth	Bore Dia.*	
UNC	UNF	tpi	Internal	D	D2	L	L1	Z	Zt	mm
	No.1-72	72	D3T03014L057-I72UNTM...	3	1.45	30	5.75	3	3	1.6
	No.1-72	72	D3T06014L057-I72UNTM...	6	1.45	57	5.75	3	3	1.6
No.2-56	No.3-56	56	D3T03016L070-I56UNTM...	3	1.65	30	7.0	3	3	1.8
No.4, No.5-40	No.6-40	40	D3T03021L090-I40UNTM...	3	2.10	30	9.0	3	3	2.3
No.4, No.5-40	No.6-40	40	D3T06021L090-I40UNTM...	6	2.10	57	9.0	3	3	2.3
No.5-40	No.6-40	40	D3T06024L100-I40UNTM...	6	2.45	57	10.0	3	3	2.6
No.6, No.8-32	No.10-32	32	D3T03025L110-I32UNTM...	3	2.55	30	11.0	3	3	2.8
No.6, No.8-32	No.10-32	32	D3T06025L110-I32UNTM...	6	2.55	57	11.0	3	3	2.8
No.8-32	No.10-32	32	D3T06032L130-I32UNTM...	6	3.20	57	13.0	3	3	3.4
	No.10-32	32	D3T06038L150-I32UNTM...	6	3.80	57	15.1	3	3	4.0
No.12-28	1/4"x28	28	D3T06044L170-I28UNTM...	6	4.40	57	17.0	3	3	4.7
	1/4"x28	28	D3T06052L196-I28UNTM...	6	5.25	57	19.6	3	3	5.5
	5/16"x24	24	D3T08066L245-I24UNTM...	8	6.68	63	24.5	3	3	6.9
1/4"x20	7/16"x20	20	D3T06048L198-I20UNTM...	6	4.88	57	19.8	3	3	5.1
5/16"x18		18	D3T08061L239-I18UNTM...	8	6.15	63	24.0	3	3	6.6

* Bore diameter applies to smallest thread dia.

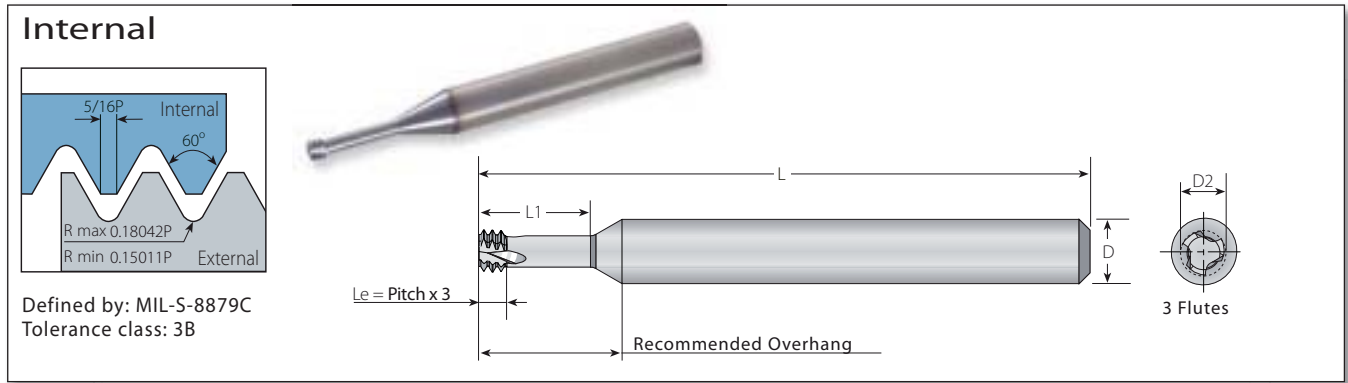

MilliPro - Miniature Thread Mills

3 x Do (L1 ≤ 3 x Thread Diameter)

Thread	Pitch	Ordering Code	Dimensions mm				No. of Flutes	Teeth	Bore Dia.*
UNJC	UNJF	Internal	D	D2	L	L1	Z	Zt	mm
0.138" (#6)	0.190" (#10)	D3T06027L110-I32UNJTM...	6	2.70	57	11.0	3	3	2.8
	0.250" (1/4")	D3T06054L195-I28UNJTM...	6	5.40	57	19.5	3	3	5.6
0.190" (#10)		D3T06037L149-I24UNJTM...	6	3.70	57	14.9	3	3	4.0
	0.3125" (5/16")	D3T08067L241-I24UNJTM...	8	6.70	63	24.1	3	3	7.0
0.250" (1/4")		D3T06050L195-I20UNJTM...	6	5.00	57	19.5	3	3	5.3
	0.4375" (7/16")	D3T10096L335-I20UNJTM...	10	9.60	73	33.5	3	3	10.0
0.3125" (5/16")	0.5625" (9/16")	D3T08064L241-I18UNJTM...	8	6.40	63	24.1	3	3	6.75
0.375" (3/8")	0.750" (3/4")	D3T08077L290-I16UNJTM...	8	7.70	63	29.0	3	3	8.1
0.4375" (7/16")	0.875" (7/8")	D3T10092L335-I14UNJTM...	10	9.20	73	33.5	3	3	9.5
0.500" (1/2")		D3T10099L385-I13UNJTM...	10	9.90	73	38.5	3	3	11.0

MJ

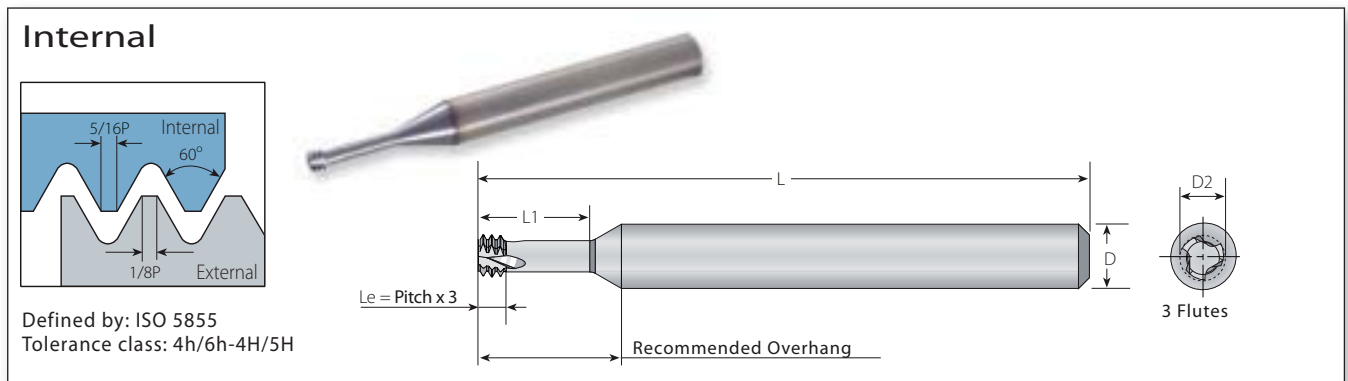

MilliPro - Miniature Thread Mills

3 x Do (L1 ≤ 3 x Thread Diameter)

Thread	Pitch	Ordering Code	Dimensions mm				No. of Flutes	Teeth	Bore Dia.
Standard	mm	Internal	D	D2	L	L1	Z	Zt	mm
MJ3x0.5	0.5	D3T06024L092-I0.5MJTM...	6	2.40	57	9.2	3	3	2.6
MJ3.5x0.6	0.6	D3T06028L110-I0.6MJTM...	6	2.85	57	11.0	3	3	3.0
MJ4x0.7	0.7	D3T06031L123-I0.7MJTM...	6	3.15	57	12.3	3	3	3.4
MJ5x0.8	0.8	D3T06040L154-I0.8MJTM...	6	4.05	57	15.4	3	3	4.3
MJ6x1.0	1.0	D3T06048L185-I1.0MJTM...	6	4.80	57	18.5	3	3	5.1
MJ8x1.25	1.25	D3T08065L246-I1.25MJTM...	8	6.50	63	24.6	3	3	6.9
MJ10x1.5	1.50	D3T10082L308-I1.50MJTM...	10	8.20	73	30.8	3	3	8.7
MJ12x1.75	1.75	D3T10099L370-I1.75MJTM...	10	9.90	73	37.0	3	3	10.4
MJ14x2	2.0	D3T12119L425-I2.0MJTM...	12	11.90	83	42.5	3	3	12.25

* Bore diameter applies to smallest thread dia.

ISO Metric

MilliPro Dental

Internal

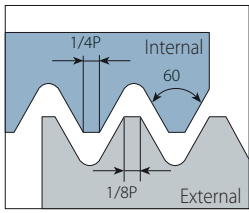

Defined by: R262 (DIN 13)
Tolerance class: 6H

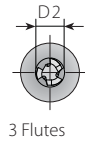
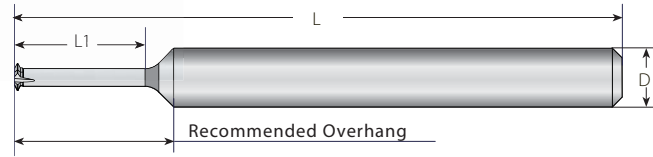

MilliPro Dental

Miniature Thread Mills for Dental Implants

3xDo (L1 ≤ 3 x Thread Diameter)

Thread		Pitch	Ordering Code	Dimensions mm				No. of Flutes	Teeth	Bore Dia.
M Coarse	M Fine	mm	Internal	D	D2	L	L1	Z	Zt	mm
M1.0x0.25	M1.4x0.25	0.25	D1T03007L031-I0.25ISOTM...	3	0.70	31	3.1	3	1	0.75
M1.2x0.25	M1.4x0.25	0.25	D1T03009L038-I0.25ISOTM...	3	0.90	31	3.8	3	1	0.95
M1.4x0.3	-	0.30	D1T03011L044-I0.30ISOTM...	3	1.05	31	4.4	3	1	1.15
M1.6x0.35	-	0.35	D1T03012L050-I0.35ISOTM...	3	1.20	31	5.0	3	1	1.30
M1.8x0.35	M2.0x0.35	0.35	D1T03014L056-I0.35ISOTM...	3	1.40	31	5.6	3	1	1.50
M2.0x0.4	-	0.40	D1T03015L062-I0.40ISOTM...	3	1.50	31	6.2	3	1	1.65
M2.5x0.45	-	0.45	D1T03019L077-I0.45ISOTM...	3	1.95	31	7.7	3	1	2.10

American UN

MilliPro Dental

Internal

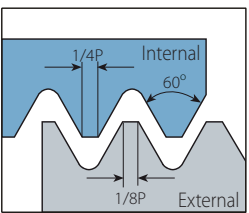

Defined by: ANSI B1.1:74
Tolerance class: 2B

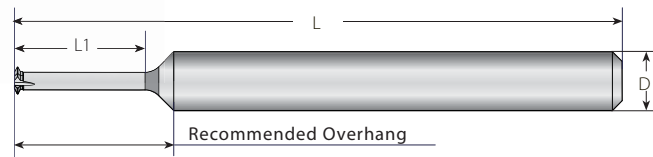

MilliPro Dental

Miniature Thread Mills for Dental Implants

3xDo (L1 ≤ 3 x Thread Diameter)

Thread		Pitch	Ordering Code	Dimensions mm				No. of Flutes	Teeth	Bore Dia.
UNF		tpi	Internal	D	D2	L	L1	Z	Zt	mm
0-80		80	D1T03011L046-I80UNTM...	3	1.15	31	4.6	3	1	1.30
1-72		72	D1T03014L065-I72UNTM...	3	1.45	31	6.5	3	1	1.60

The MilliPro Dental line was specially designed for machining Titanium and Stainless Steel in high RPM. MilliPro Dental D1T tools are also suitable for general use applications.

ISO Metric

MilliPro EL

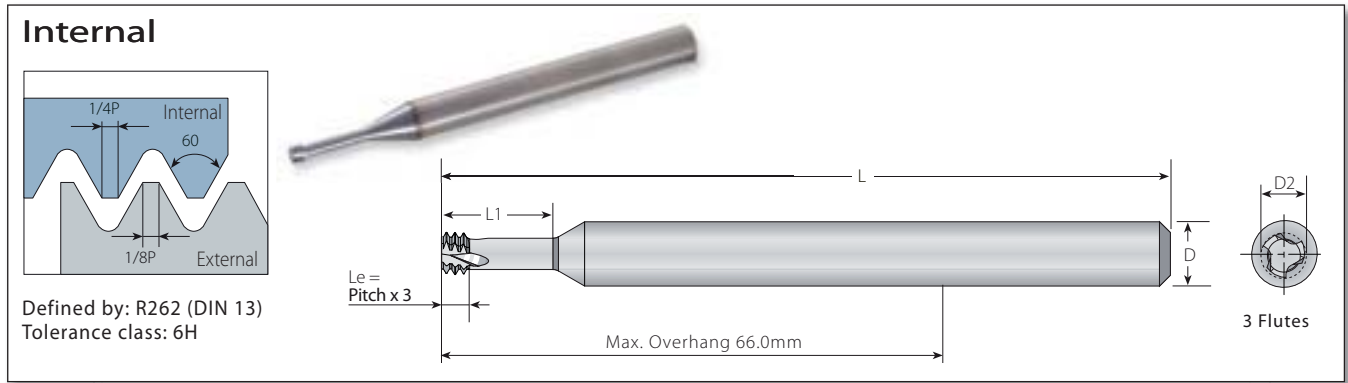

MilliPro EL Miniature Thread Mills , Extra Long Tools

2 x Do (L1 ≤ 2 x Thread Diameter)

Thread		Pitch	Ordering Code	Dimensions mm				No. of Flutes	Teeth	Bore Dia.*
M Coarse	M Fine	mm	Internal	D	D2	L	L1	Z	Zt	mm
M2x0.4		0.4	D3T06015L042-10.4ISOTML...	6	1.55	100	4.2	3	3	1.6
M2.5x0.45		0.45	D3T06019L052-10.45ISOTML...	6	1.95	100	5.2	3	3	2.05
M3x0.5	M3.5-M16x0.5	0.5	D3T06024L062-10.5ISOTML...	6	2.40	100	6.2	3	3	2.5

American UN

MilliPro EL

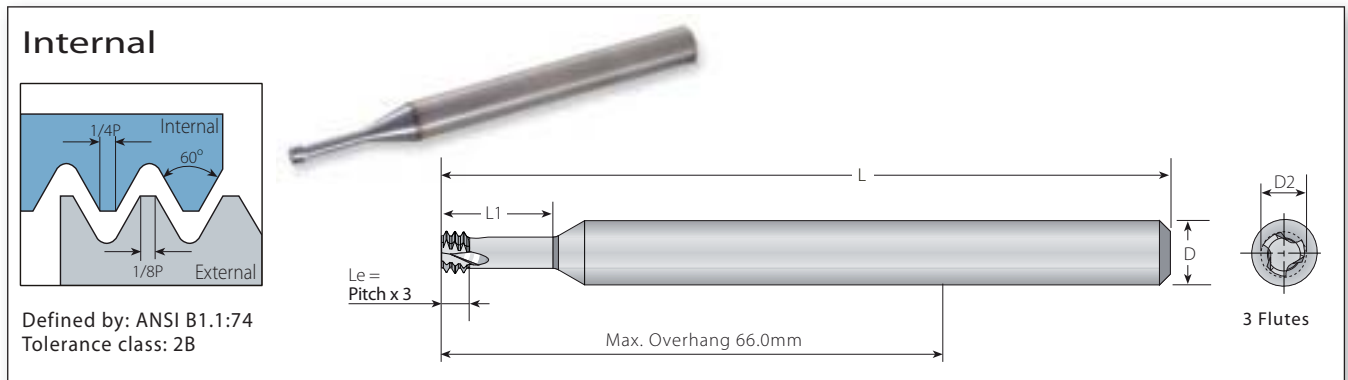

MilliPro EL Miniature Thread Mills, Extra Long Tools

2 x Do (L1 ≤ 2 x Thread Diameter)

Thread		Pitch	Ordering Code	Dimensions mm				No. of Flutes	Teeth	Bore Dia.*
UNC	UNF	tpi	Internal	D	D2	L	L1	Z	Zt	mm
No.2-56	No.3-56	56	D3T06016L050-156UNTML...	6	1.65	100	5.0	3	3	1.8
No.4, No.5-40	No.6-40	40	D3T06021L060-140UNTML...	6	2.10	100	6.0	3	3	2.3
No.6, No.8-32	No.10-32	32	D3T06025L074-132UNTML...	6	2.55	100	7.4	3	3	2.8
No.8-32	No.10-32	32	D3T06032L100-132UNTML...	6	3.20	100	10.0	3	3	3.4

* Bore diameter applies to smallest thread dia.

Internal

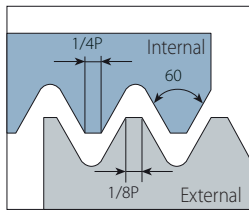

Defined by: R262 (DIN 13)
Tolerance class: 6H

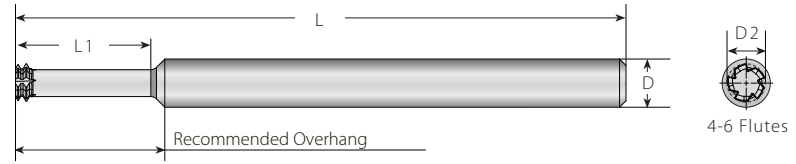

Left Hand Tool

MilliPro HD

Miniature Thread Mills for Hard Materials Up to 62HRc

2 x Do (L1 ≤ 2 x Thread Diameter)

Thread		Pitch	Ordering Code	Dimensions mm				No. of Flutes	Teeth	Bore Dia.*
M Coarse	M Fine	mm	Internal	D	D2	L	L1	Z	Zt	mm
M2x0.4		0.4	S2L06015L042-I0.4ISOTM...	6	1.55	76	4.60	4	2	1.6
M2.2x0.45		0.45	S2L06016L046-I0.45ISOTM...	6	1.65	76	5.05	4	2	1.8
M2.5x0.45		0.45	S2L06019L052-I0.45ISOTM...	6	1.95	76	5.65	4	2	2.05
M3x0.5	M3.5-M16x0.5	0.5	S2L06024L062-I0.5ISOTM...	6	2.40	76	6.75	4	2	2.55
M3.5x0.6		0.6	S2L06027L073-I0.6ISOTM...	6	2.75	76	7.90	4	2	2.95
M4x0.7		0.7	S2L06031L083-I0.7ISOTM...	6	3.15	76	9.05	4	2	3.35
M5x0.8		0.8	S2L06040L104-I0.8ISOTM...	6	4.05	76	11.20	4	2	4.3
M6x1.0	M8-M40x1.0	1.0	S2L06048L125-I1.0ISOTM...	6	4.80	76	13.50	5	2	5.1
M8x1.25		1.25	S2L08065L166-I1.25ISOTM...	8	6.50	80	17.85	5	2	6.8
M10x1.5	M12-M48x1.50	1.50	S2L08079L208-I1.50ISOTM...	8	7.90	80	22.30	6	2	8.6
M12x1.75		1.75	S2L10099L250-I1.75ISOTM...	10	9.90	101	26.75	6	2	10.4

MilliPro HD

Miniature Thread Mills for Hard Materials Up to 62HRc

3 x Do (L1 ≤ 3 x Thread Diameter)

Thread		Pitch	Ordering Code	Dimensions mm				No. of Flutes	Teeth	Bore Dia.*
M Coarse	M Fine	mm	Internal	D	D2	L	L1	Z	Zt	mm
M2x0.4		0.4	S2L06015L062-I0.4ISOTM...	6	1.55	76	6.60	4	2	1.6
M2.5x0.45		0.45	S2L06019L077-I0.45ISOTM...	6	1.95	76	8.15	4	2	2.05
M3x0.5	M3.5-M16x0.5	0.5	S2L06024L092-I0.5ISOTM...	6	2.40	76	9.75	4	2	2.55
M4x0.7		0.7	S2L06031L123-I0.7ISOTM...	6	3.15	76	13.05	4	2	3.35
M5x0.8		0.8	S2L06040L154-I0.8ISOTM...	6	4.05	76	16.20	4	2	4.3
M6x1.0	M8-M40x1.0	1.0	S2L06048L185-I1.0ISOTM...	6	4.80	76	19.50	5	2	5.1
M8x1.25		1.25	S2L08065L246-I1.25ISOTM...	8	6.50	80	25.85	5	2	6.8

Roughing (Partial Profile)

Finish (Full Profile)

Two cutting teeth: Partial Profile for leading tooth followed by Full Profile for finishing.

The work direction should be from the top to the bottom (Climb Milling).

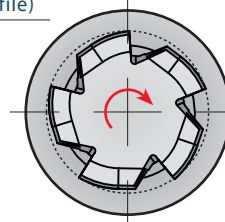
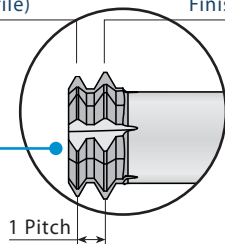

MilliPro HD Tools are left handed. For CNC use M04 code.

* Bore diameter applies to smallest thread dia.

Internal

Defined by: ANSI B1.1:74
Tolerance class: 2B

Left Hand Tool

MilliPro HD

Miniature Thread Mills for Hard Materials Up to 62HRc

2 x Do (L1 ≤ 2 x Thread Diameter)

Thread		Pitch	Ordering Code	Dimensions mm			No. of Flutes	Teeth	Bore Dia.*	
UNC	UNF	tpi	Internal	D	D2	L	L1	Z	Zt	mm
No.2-56	No.3-56	56	S2L06016L050-I56UNTM...	6	1.65	76	5.45	4	2	1.80
No.3-48	No.4-48	48	S2L06019L060-I48UNTM...	6	1.90	76	6.53	4	2	2.10
No.4-40, No.5-40	No.6-40	40	S2L06021L060-I40UNTM...	6	2.10	76	6.64	4	2	2.35
No.5-40	No.6-40	40	S2L06024L072-I40UNTM...	6	2.45	76	7.84	4	2	2.65
	No.8-36	36	S2L06033L087-I36UNTM...	6	3.30	76	9.41	4	2	3.55
No.6-32, No.8-32	No.10-32	32	S2L06025L074-I32UNTM...	6	2.55	76	8.20	4	2	2.85
No.8-32	No.10-32	32	S2L06032L100-I32UNTM...	6	3.20	76	10.79	4	2	3.50
	No.10-32	32	S2L06037L100-I32UNTM...	6	3.70	76	10.80	4	2	4.17
	1/4"x28	28	S2L06052L132-I28UNTM...	6	5.25	76	14.11	5	2	5.55
No.10-24	5/16"x24	24	S2L06035L102-I24UNTM...	6	3.58	76	11.26	4	2	3.90
	5/16"x24	24	S2L08066L165-I24UNTM...	8	6.68	80	17.56	5	2	7.00
1/4"-20	7/16"x20	20	S2L06048L134-I20UNTM...	6	4.88	76	14.67	5	2	5.20
	7/16"x20	20	S2L10095L230-I20UNTM...	10	9.55	101	24.27	6	2	9.90
5/16"x18		18	S2L08061L160-I18UNTM...	8	6.15	80	18.17	4	2	6.50
3/8"x16		16	S2L08076L197-I16UNTM...	8	7.65	80	21.29	5	2	8.00
7/16"x14		14	S2L10090L233-I14UNTM...	10	9.00	101	25.11	6	2	9.50
1/2"x13		13	S2L10099L256-I13UNTM...	10	9.90	101	27.55	6	2	10.90

MilliPro HD

Miniature Thread Mills for Hard Materials Up to 62HRc

3 x Do (L1 ≤ 3 x Thread Diameter)

Thread		Pitch	Ordering Code	Dimensions mm			No. of Flutes	Teeth	Bore Dia.*	
UNC	UNF	tpi	Internal	D	D2	L	L1	Z	Zt	mm
No.4-40, No.5-40	No.6-40	40	S2L06021L090-I40UNTM...	6	2.10	76	9.64	4	2	2.35
No.5-40	No.6-40	40	S2L06024L100-I40UNTM...	6	2.45	76	10.64	4	2	2.65
No.6-32, No.8-32	No.10-32	32	S2L06025L110-I32UNTM...	6	2.55	76	11.79	4	2	2.85
No.8-32	No.10-32	32	S2L06032L130-I32UNTM...	6	3.20	76	13.79	4	2	3.50
	1/4"x28	28	S2L06052L196-I28UNTM...	6	5.25	76	20.51	5	2	5.55
	5/16"x24	24	S2L08066L245-I24UNTM...	8	6.68	80	25.56	5	2	7.00
1/4"x20	7/16"x20	20	S2L06048L198-I20UNTM...	6	4.88	76	21.07	5	2	5.20
5/16"x18		18	S2L08061L240-I18UNTM...	8	6.15	80	26.17	4	2	6.50
7/16"x14		14	S2L10090L335-I14UNTM...	10	9.00	101	35.31	6	2	9.50

Roughing (Partial Profile)

Two cutting teeth: Partial Profile for leading tooth followed by Full Profile for finishing.

The work direction should be from the top to the bottom (Climb Milling).

Finish (Full Profile)

MilliPro HD Tools are left handed. For CNC use M04 code.

* Bore diameter applies to smallest thread dia.

Tap 60°, Tap 55°

Straight

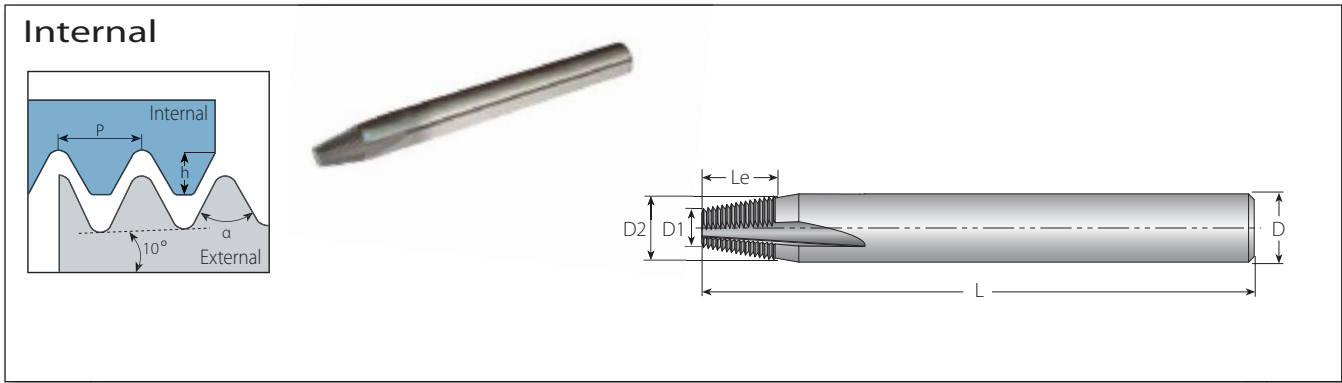

Straight Flutes - Taper 60°

TM Solid Straight Flutes for Bone Plate Applications

Pitch	Ordering Code	Taper	Thread Angle	Profile Height	Dimensions mm					No. of Flutes	Teeth
mm	Internal		α	h	D	D2	D1	L	Le	Z	Zt
0.4	S06059L080-10.4TAP60TM...	20°	60°	0.20	6	5.9	3.2	57	8.0	3	20
0.5	S06059L090-10.5TAP60TM...	20°	60°	0.25	6	5.9	2.9	57	9.0	3	18

Straight Flutes - Taper 55°

TM Solid Straight Flutes for Bone Plate Applications

Pitch	Ordering Code	Taper	Thread Angle	Profile Height	Dimensions mm					No. of Flutes	Teeth
mm	Internal		α	h	D	D2	D1	L	Le	Z	Zt
0.3	S03028L039-10.3TAP55TM...	20°	55°	0.18	3	2.8	1.5	38	3.9	3	13
0.35	S04039L063-10.35TAP55TM...	20°	55°	0.20	4	3.9	1.8	45	6.3	3	18
0.4	S06059L100-10.4TAP55TM...	20°	55°	0.29	6	5.9	2.5	57	10.0	3	25
0.5	S06059L090-10.5TAP55TM...	20°	55°	0.33	6	5.9	2.9	57	9.0	3	18
0.6	S06059L066-10.6TAP55TM...	20°	55°	0.47	6	5.9	3.8	57	6.6	3	11

External / Internal

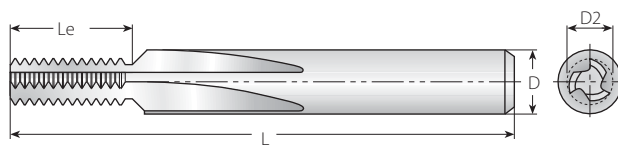
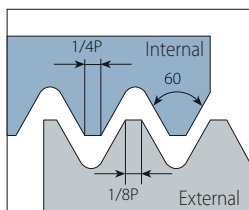

Defined by: R262 (DIN 13)
Tolerance class: 6g/6H

Straight Flutes - External

Thread	Pitch	Ordering Code	Dimensions mm				No. of Flutes	Teeth	
Min. Dia.	mm	External	D	D2	L	Le	Z	Zt	h mm
M3	0.50	S06059-E0.5ISOTM...	6	5.90	57	15.0	3	30	0.31
M4.5	0.75	S08079-E0.75ISOTM...	8	7.90	63	19.5	3, 5 *	26	0.46
M6	1.00	S10099-E1.0ISOTM...	10	9.90	72	24.0	5	24	0.61
M10	1.50	S12119-E1.5ISOTM...	12	11.90	83	30.0	5	20	0.92
M14	2.00	S12119-E2.0ISOTM...	12	11.90	83	30.0	5	15	1.23
M24	3.00	S16159-E3.0ISOTM...	16	15.90	92	36.0	5	12	1.84
M36	4.00	S16159-E4.0ISOTM...	16	15.90	92	40.0	5	10	2.45
M64	6.00	S20199-E6.0ISOTM...	20	19.90	104	36.0	5	6	3.68

Straight Flutes - Internal

Thread	Pitch	Ordering Code	Dimensions mm				No. of Flutes	Teeth	
Min. Dia.	mm	Internal	D	D2	L	Le	Z	Zt	h mm
M4.5	0.75	S04030-I0.75ISOTM...	4	3.00	42	6.7	3	9	0.43
M8	0.75	S06059-I0.75ISOTM...	6	5.90	57	15.0	3	20	0.43
M5	0.80	S04036-I0.8ISOTM...	4	3.60	42	8.0	3	10	0.46
M6	1.00	S06040-I1.0ISOTM...	6	4.00	57	9.0	3	9	0.58
M12	1.00	S08079-I1.0ISOTM...	8	7.90	63	20.0	3, 5 *	20	0.58
M8	1.25	S06050-I1.25ISOTM...	6	5.00	57	12.5	3	10	0.72
M10	1.50	S06059-I1.5ISOTM...	6	5.90	57	15.0	3	10	0.87
M14	1.50	S10099-I1.5ISOTM...	10	9.90	72	24.0	5	16	0.87
M18	1.50	S12119-I1.5ISOTM...	12	11.90	83	30.0	5	20	0.87
M12	1.75	S08079-I1.75ISOTM...	8	7.90	63	19.2	3, 5 *	11	1.01
M16	2.00	S10099-I2.0ISOTM...	10	9.90	72	24.0	5	12	1.15
M18	2.00	S12119-I2.0ISOTM...	12	11.90	83	30.0	5	15	1.15
M20	2.50	S12119-I2.5ISOTM...	12	11.90	83	30.0	5	12	1.44
M24	3.00	S16159-I3.0ISOTM...	16	15.90	92	36.0	5	12	1.73
M30	3.50	S16159-I3.5ISOTM...	16	15.90	92	38.5	5	11	2.02
M36	4.00	S16159-I4.0ISOTM...	16	15.90	92	40.0	5	10	2.31
M48	5.00	S20199-I5.0ISOTM...	20	19.90	104	40.0	5	8	2.89
M64	6.00	S20199-I6.0ISOTM...	20	19.90	104	36.0	5	6	3.46

* Available in 3 and 5 flutes. Add 3 or 5 to the ordering code (TM3.../TM5...).

American UN

Straight

External / Internal

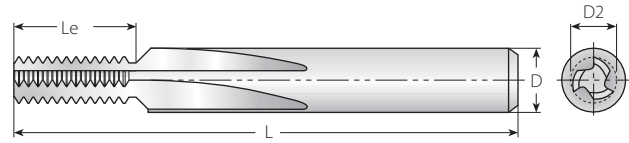
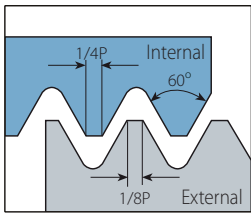

Defined by: ANSI B1.1:74
Tolerance class: 2A/2B

Straight Flutes - External

Thread	Pitch	Ordering Code	Dimensions mm				No. of Flutes	Teeth	
Min. Dia.	tpi	External	D	D2	L	Le	Z	Zt	h mm
No.6	32	S06059-E32UNTM...	6	5.90	57	14.3	3	18	0.49
No.12	28	S08079-E28UNTM...	8	7.90	63	19.9	3, 5*	22	0.56
1/4"	20	S10099-E20UNTM...	10	9.90	72	22.9	5	18	0.78
5/16"	18	S10099-E18UNTM...	10	9.90	72	24.0	5	17	0.87
3/8"	16	S12119-E16UNTM...	12	11.90	83	28.6	5	18	0.97
9/16"	12	S12119-E12UNTM...	12	11.90	83	29.6	5	14	1.30
1"	8	S16159-E8UNTM...	16	15.90	92	38.1	5	12	1.95
1 3/8"	6	S20199-E6UNTM...	20	19.90	104	38.1	5	9	2.60

Straight Flutes - Internal

Thread	Pitch	Ordering Code	Dimensions mm				No. of Flutes	Teeth	
Min. Dia.	tpi	Internal	D	D2	L	Le	Z	Zt	h mm
No.8	36	S04030-I36UNTM...	4	3.00	42	6.3	3	9	0.41
No.8	32	S04030-I32UNTM...	4	3.00	42	6.3	3	8	0.46
5/16"	32	S06059-I32UNTM...	6	5.90	57	14.3	3	18	0.46
No.12	28	S04036-I28UNTM...	4	3.60	42	8.2	3	9	0.52
7/16"	28	S08079-I28UNTM...	8	7.90	63	19.9	3, 5*	22	0.52
No.12	24	S06040-I24UNTM...	6	4.00	57	8.5	3	8	0.61
1/4"	20	S06040-I20UNTM...	6	4.00	57	10.2	3	8	0.73
9/16"	20	S10099-I20UNTM...	10	9.90	72	22.9	5	18	0.73
5/16"	18	S06050-I18UNTM...	6	5.00	57	12.7	3	9	0.81
9/16"	18	S10099-I18UNTM...	10	9.90	72	24.0	5	17	0.81
3/8"	16	S06059-I16UNTM...	6	5.90	57	14.3	3	9	0.92
3/4"	16	S12119-I16UNTM...	12	11.90	83	28.6	5	18	0.92
7/16"	14	S08079-I14UNTM...	8	7.90	63	18.1	3, 5*	10	1.05
1/2"	13	S08079-I13UNTM...	8	7.90	63	19.5	3, 5*	10	1.13
9/16"	12	S10099-I12UNTM...	10	9.90	72	23.3	5	11	1.22
1"	12	S12119-I12UNTM...	12	11.90	83	29.6	5	14	1.22
5/8"	11	S10099-I11UNTM...	10	9.90	72	23.1	5	10	1.33
3/4"	10	S12119-I10UNTM...	12	11.90	83	27.9	5	11	1.47
7/8"	9	S16159-I9UNTM...	16	15.90	92	33.3	5	12	1.63
1"	8	S16159-I8UNTM...	16	15.90	92	38.1	5	12	1.83
1 1/8"	7	S16159-I7UNTM...	16	15.90	92	36.3	5	10	2.09
1 3/8"	6	S20199-I6UNTM...	20	19.90	104	38.1	5	9	2.44
1 3/4"	5	S20199-I5UNTM...	20	19.90	104	40.6	5	8	2.93
2"	4.5	S20199-I4.5UNTM...	20	19.90	104	39.5	5	7	3.26

* Available in 3 and 5 flutes. Add 3 or 5 to the ordering code (TM3.../TM5...).

BSW

Straight

External / Internal

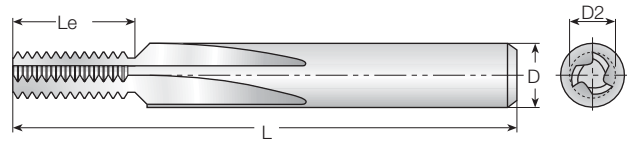
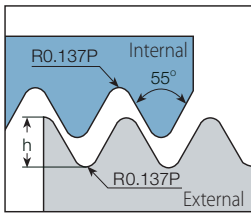

Defined by: B.S.84:1956, DIN 259, ISO228/1:1982
Tolerance class: Medium class A

Straight Flutes

Thread	Pitch	Ordering Code	Dimensions mm				No. of Flutes	Teeth	
Min. Dia.	tpi	External / Internal	D	D2	L	Le	Z	Zt	h mm
1/4"	20	S06040-EI20BSWTM...	6	4.00	57	10.16	3	8	0.81
5/16"	18	S06050-EI18BSWTM...	6	5.00	57	11.29	3	8	0.90
3/8"	16	S06059-EI16BSWTM...	6	5.90	57	14.29	3	9	1.02
7/16"	14	S08079-EI14BSWTM...	8	7.90	63	18.14	3,5*	10	1.16
1/2"	12	S08079-EI12BSWTM...	8	7.90	63	19.05	3,5*	9	1.36
5/8"	11	S10099-EI11BSWTM...	10	9.90	72	23.09	5	10	1.48
3/4"	10	S12119-EI10BSWTM...	12	11.90	83	27.94	5	11	1.63
7/8"	9	S12119-EI9BSWTM...	12	11.90	83	28.22	5	10	1.81
1"	8	S16159-EI8BSWTM...	16	15.90	92	38.10	5	12	2.03
1 1/8"	7	S16159-EI7BSWTM...	16	15.90	92	36.29	5	10	2.32
1 3/8"	6	S16159-EI6BSWTM...	16	15.90	92	38.10	5	9	2.71
1 5/8"	5	S20199-EI5BSWTM...	20	19.90	104	40.64	5	8	3.25
1 7/8"	4.5	S20199-EI4.5BSWTM...	20	19.90	104	39.51	5	7	3.61

BSP

Straight

External / Internal

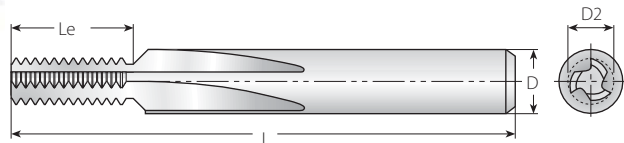
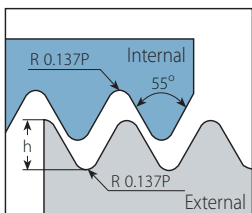

Defined by: B.S.2779:1956
Tolerance class: Medium class

Straight Flutes

Thread	Pitch	Ordering Code	Dimensions mm				No. of Flutes	Teeth	
Min. Dia.	tpi	External / Internal	D	D2	L	Le	Z	Zt	h mm
1/16"	28	S06059-EI28BSPTM...	6	5.90	57	14.51	3	16	0.58
1/4"	19	S08079-EI19BSPTM...	8	7.90	63	18.72	3,5*	14	0.86
1/2"	14	S12119-EI14BSPTM...	12	11.90	83	29.03	5	16	1.16
1"	11	S16159-EI11BSPTM...	16	15.90	92	34.64	5	15	1.48

* Available in 3 and 5 flutes. Add 3 or 5 to the ordering code (TM3.../TM5...).

BSPT

Straight

External / Internal

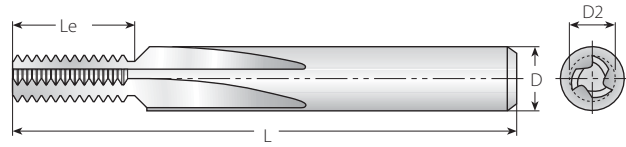
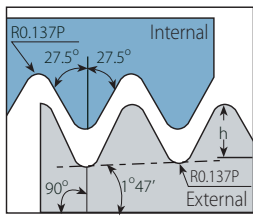

Defined by: B.S.21:1985
Tolerance class: Standard BSPT

Straight Flutes

Thread	Pitch	Ordering Code	Dimensions mm				No. of Flutes	Teeth	
Min. Dia.	tpi	External / Internal	D	D2	L	Le	Z	Zt	h mm
1/16"	28	S06059-EI28BSPT-TM...	6	5.90	57	9.98	3	11	0.58
1/4"	19	S08079-EI19BSPT-TM...	8	7.90	63	14.71	3, 5*	11	0.86
1/2"	14	S12119-EI14BSPT-TM...	12	11.90	83	19.96	5	11	1.16
1"	11	S16159-EI11BSPT-TM...	16	15.90	92	39.25	5	17	1.48

NPT

Straight

External / Internal

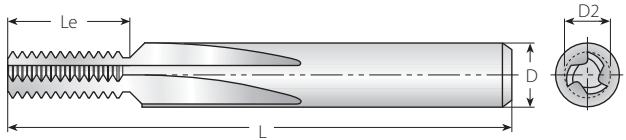
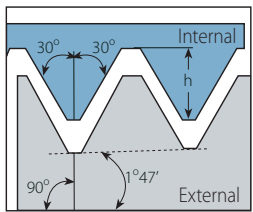

Defined by: USAS B2.1:1968
Tolerance class: Standard NPT

Straight Flutes

Thread	Pitch	Ordering Code	Dimensions mm				No. of Flutes	Teeth	
Min. Dia.	tpi	External / Internal	D	D2	L	Le	Z	Zt	h mm
1/16"	27	S06059-EI27NPT-TM...	6	5.90	57	9.41	3	10	0.66
1/4"	18	S08079-EI18NPT-TM...	8	7.90	63	14.11	3, 5*	10	1.01
1/2"	14	S12119-EI14NPT-TM...	12	11.90	83	19.96	5	11	1.33
1"	11.5	S16159-EI11.5NPT-TM...	16	15.90	92	26.51	5	12	1.64
2 1/2"	8	S16159-EI8NPT-TM...	16	15.90	92	38.10	5	12	2.42

* Available in 3 and 5 flutes. Add 3 or 5 to the ordering code (TM3.../TM5...).

ANPT

Straight

External / Internal

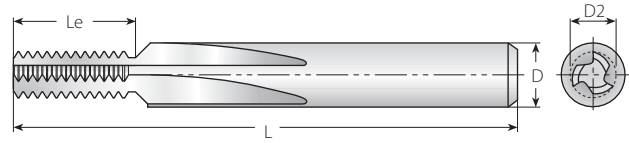
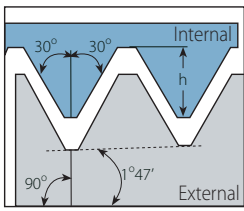

Defined by: MIL-P-7105B
Tolerance class: Standard ANPT

Straight Flutes

Thread	Pitch	Ordering Code	Dimensions mm				No. of Flutes	Teeth	
Min. Dia.	tpi	External / Internal	D	D2	L	Le	Z	Zt	h mm
1/4"	18	S08079-EI18ANPT-TM...	8	7.90	63	14.11	5	10	1.10
1/2"	14	S12119-EI14ANPT-TM...	12	11.90	83	19.96	5	11	1.42

NPTF

Straight

External / Internal

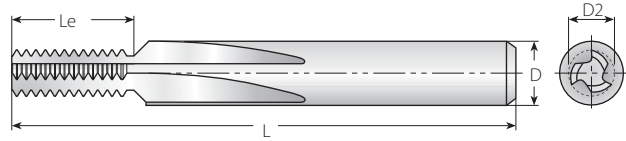
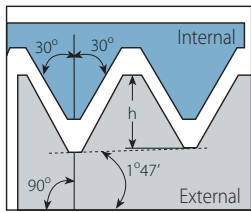

Defined by: ANSI 1.20.3-1976
Tolerance class: Standard NPTF

Straight Flutes

Thread	Pitch	Ordering Code	Dimensions mm				No. of Flutes	Teeth	
Min. Dia.	tpi	External / Internal	D	D2	L	Le	Z	Zt	h mm
1/16"	27	S06059-EI27NPTFTM...	6	5.90	57	9.41	3	10	0.64
1/4"	18	S08079-EI18NPTFTM...	8	7.90	63	14.11	3, 5*	10	1.0
1/2"	14	S12119-EI14NPTFTM...	12	11.90	83	19.96	5	11	1.35
1"	11.5	S16159-EI11.5NPTFTM...	16	15.90	92	26.51	5	12	1.63
2 1/2"	8	S16159-EI8NPTFTM...	16	15.90	92	38.10	5	12	2.38

Pg

Straight

External / Internal

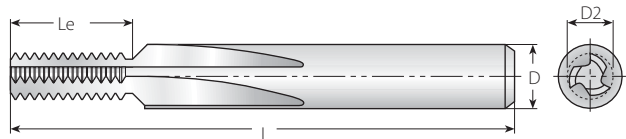
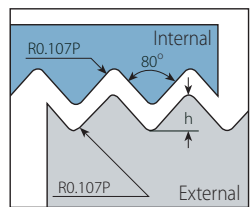

Defined by: DIN 40430
Tolerance class: Standard

Straight Flutes

Thread	Pitch	Ordering Code	Dimensions mm				No. of Flutes	Teeth	
	tpi	External / Internal	D	D2	L	Le	Z	Zt	h mm
Pg7	20	S08079-EI20PGTM...	8	7.90	63	19.05	3, 5*	15	0.61
Pg9, 11, 13.5, 16	18	S10099-EI18PGTM...	10	9.90	72	23.99	5	17	0.67
Pg21, 29, 36, 42, 48	16	S12119-EI16PGTM...	12	11.90	83	28.58	5	18	0.76

* Available in 3 and 5 flutes. Add 3 or 5 to the ordering code (TM3.../TM5...).

Grades and Their Applications

VTH

Helicool HCR HCC

MilliPro MilliPro Dental MilliPro HD

MilliPro EL Deep Threading Helical

- A general-purpose, heavy duty thread milling grade
- TiCN coated for high resistance to wear

VTS

Straight

- A general-purpose grade, specially designed for TM Solid Straight Flute cutters
- TiAlN coated for high resistance to wear

VTS

HTC (Thriller)

- TiAlN coated grade
- First choice for Cast Iron and general use

VTN

HTC (Thriller)

- Uncoated grade
- First choice for Aluminium and general use



TM Solid

Recommended Cutting Speeds Vc [m/min] and Feed f [mm/tooth]

Material Group	Vargus No.	Material	Hardness Brinell HB	Vc [m/min]			Feed [mm/tooth]					
				Helicoil, HCR, HCC, Helical, Sraight, Deep Threading		MilliPro	Helical	Straight	Deep Threading	Helicoil HCC HCR	MilliPro	
				VTH	VTS	VTH						
P Steel	1	Unalloyed Steel	Low Carbon (C=0.1-0.25%)	125	80-250	50-180	60-120	0.03-0.08	0.03-0.08	0.10-0.35	0.03-0.08	0.02-0.16
	2		Medium Carbon (C=0.25-0.55%)	150	80-230	50-140	60-120	0.03-0.08	0.03-0.08	0.08-0.30	0.03-0.08	0.02-0.16
	3		High Carbon (C=0.55-0.85%)	170	80-200	50-120	60-90	0.03-0.08	0.03-0.06	0.08-0.30	0.03-0.08	0.02-0.16
	4	Low Alloy Steel (alloying elements ≤5%)	Non Hardened	180	60-180	60-170	60-90	0.03-0.08	0.03-0.07	0.08-0.30	0.03-0.08	0.02-0.16
	5		Hardened	275	60-170	60-160	50-80	0.03-0.07	0.03-0.07	0.08-0.30	0.03-0.07	0.02-0.07
	6		Hardened	350	60-160	60-150	50-80	0.02-0.05	0.02-0.04	0.05-0.15	0.02-0.06	0.02-0.03
	7	High Alloy Steel (alloying elements >5%)	Annealed	200	40-100	40-90	50-80	0.03-0.07	0.03-0.07	0.10-0.24	0.03-0.07	0.02-0.09
	8		Hardened	325	30-80	30-70	50-80	0.02-0.04	0.02-0.05	0.05-0.15	0.03-0.06	0.02-0.03
	9	Cast Steel	Low Alloy (alloying elements <5%)	200	80-250	70-200	70-90	0.03-0.08	0.03-0.06	0.08-0.30	0.03-0.07	0.02-0.16
	10		High Alloy (alloying elements >5%)	225	60-170	60-150	60-80	0.03-0.05	0.03-0.06	0.05-0.15	0.03-0.07	0.02-0.03
M Stainless Steel	11	Stainless Steel Ferritic	Non Hardened	200	60-150	50-140	60-90	0.04-0.07	0.02-0.05	0.11-0.35	0.03-0.08	0.02-0.16
	12		Hardened	330	60-120	50-110	50-80	0.02-0.06	0.01-0.03	0.05-0.24	0.03-0.06	0.02-0.03
	13	Stainless Steel Austenitic	Austenitic	180	60-140	60-130	60-90	0.03-0.08	0.02-0.05	0.11-0.35	0.03-0.08	0.02-0.16
	14		Super Austenitic	200	60-130	50-120	50-80	0.03-0.08	0.02-0.05	0.11-0.35	0.03-0.06	0.02-0.16
	15	Stainless Steel Cast Ferritic	Non Hardened	200	60-160	50-150	60-90	0.03-0.08	0.02-0.05	0.11-0.35	0.03-0.06	0.02-0.16
	16		Hardened	330	60-110	50-100	50-80	0.02-0.05	0.02-0.03	0.10-0.24	0.02-0.05	0.02-0.03
	17	Stainless Steel Cast Austenitic	Austenitic	200	60-150	50-140	60-90	0.03-0.08	0.02-0.06	0.11-0.35	0.02-0.05	0.02-0.16
	18		Hardened	330	60-100	50-90	50-80	0.02-0.05	0.01-0.03	0.10-0.24	0.02-0.04	0.02-0.03
K Cast Iron	28	Malleable Cast Iron	Ferritic (short chips)	130	60-70	60-150	50-80	0.03-0.08	0.03-0.08	0.05-0.15	0.03-0.08	0.02-0.03
	29		Pearlitic (long chips)	230	60-150	80-100	60-90	0.03-0.08	0.03-0.06	0.10-0.24	0.03-0.07	0.02-0.12
	30	Grey Cast Iron	Low Tensile Strength	180	70-160	50-140	70-100	0.03-0.08	0.03-0.06	0.09-0.25	0.03-0.07	0.02-0.16
	31		High Tensile Strength	260	40-120	40-110	60-90	0.02-0.06	0.02-0.05	0.10-0.24	0.03-0.07	0.02-0.12
	32	Nodular Sg Iron	Ferritic	160	40-110	40-100	70-100	0.03-0.08	0.03-0.07	0.09-0.25	0.03-0.08	0.02-0.16
	33		Pearlitic	260	40-100	40-90	60-90	0.02-0.06	0.02-0.05	0.10-0.24	0.03-0.07	0.02-0.12
N Non-Ferrous Metals	34	Aluminium Alloys Wrought	Non Aging	60	200-300	150-250	60-250	0.05-0.12	0.05-0.15	0.12-0.40	0.04-0.1	0.03-0.15
	35		Aged	100	150-250	100-220	60-150	0.05-0.12	0.03-0.1	0.10-0.32	0.03-0.1	0.03-0.16
	36	Aluminium Alloys	Cast	75	100-200	80-150	60-250	0.05-0.12	0.05-0.15	0.10-0.32	0.03-0.1	0.03-0.16
	37		Cast & Aged	90	120-220	90-160	60-150	0.05-0.12	0.03-0.1	0.10-0.30	0.06-0.12	0.02-0.16
	38	Aluminium Alloys	Cast Si 13-22%	130	200-300	150-250	250	0.05-0.12	0.05-0.15	0.10-0.32	0.05-0.12	0.03-0.15
	39	Copper and Copper Alloys	Brass	90	200-300	150-250	60-250	0.06-0.13	0.05-0.15	0.12-0.40	0.05-0.12	0.03-0.16
	40		Bronze And Non Leaded Copper	100	150-250	100-220	60-150	0.05-0.12	0.03-0.1	0.10-0.32	0.05-0.12	0.03-0.15
S Heat Resistant Material	19	High Temperature Alloys	Annealed (iron based)	200	30-60	30-50	60	0.03-0.07	0.02-0.04	0.11-0.35	0.03-0.7	0.02-0.16
	20		Aged (iron based)	280	20-50	20-40	50	0.02-0.04	0.01-0.03	0.05-0.15	0.03-0.06	0.02-0.03
	21		Annealed (nickel or cobalt based)	250	15-35	15-30	35	0.02-0.04	0.01-0.03	0.05-0.15	0.03-0.06	0.02-0.03
	22		Aged (nickel or cobalt based)	350	15-30	15-25	30	0.02-0.04	0.01-0.03	0.05-0.15	0.02-0.05	0.02-0.03
	23	Titanium Alloys	Pure 99.5 Ti	400Rm	40-80	30-70	30-50	0.02-0.04	0.01-0.03	0.10-0.24	0.02-0.05	0.02-0.07
	24		α+β Alloys	1050Rm	20-50	20-45	25-35	0.02-0.04	0.01-0.02	0.10-0.24	0.02-0.04	0.02-0.07
H Hardened Material	25	Extra Hard Steel	Hardened & Tempered	45-50HRc	15-45	15-35	45	0.02-0.03	0.02	0.03-0.06	0.02-0.03	-
	26			51-55HRc	15-40	15-30	30	0.02-0.03	0.01	0.03-0.06	0.02-0.03	-

Recommendation:

At tool entry, set the Feed f [mm/tooth] to 70% lower than the threading Feed.

Example:

Threading Feed: 0.3[mm/tooth]

Tool entry Feed: 0.09[mm/tooth]

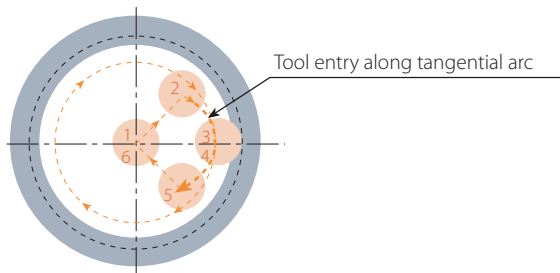

MilliPro HD Cutting Speeds Vc [m/min] and Feed f [mm/tooth]

Material Group	Vardex No.	Material	Hardness Brinell HB	Vc [m/min]		Feed f [mm/tooth] by Cutting Dia.=D2				
				VTH		1.5-2.5	2.5-5	5-7	7-9	9-11
P Steel	6	Low Alloy Steel (alloying elements≤5%) Hardened	350	25-160	0.04	0.05	0.06	0.07	0.08	
	8	High Alloy Steel (alloying elements>5%) Hardened	325	25-180						
M Stainless Steel	12	Stainless Steel Ferritic Hardened	330	25-120	0.04	0.05	0.06	0.07	0.08	
	16	Stainless Steel Cast Ferritic Hardened	330	25-110						
	18	Stainless Steel Cast Austenitic Hardened	330	25-100						
K Cast Iron	28	Malleable Cast Iron	Ferritic (short chips)	130	25-160	0.05	0.06	0.07	0.08	0.1
	29		Pearlitic (long chips)	230	25-150	0.04	0.05	0.06	0.07	0.08
	30	Grey Cast Iron	Low Tensile Strength	180	25-130	0.05	0.06	0.07	0.08	0.1
	31		High Tensile Strength	260	25-100	0.04	0.05	0.06	0.07	0.08
	32	Nodular Sg Iron	Ferritic	160	25-125	0.04	0.05	0.06	0.07	0.09
	33		Pearlitic	260	25-90	0.03	0.04	0.05	0.06	0.07
S Heat Resistant Material	21	High Temperature Alloys	Annealed (nickel or cobalt based)	250	15-35	0.03	0.04	0.05	0.06	0.07
	22		Aged (nickel or cobalt based)	350	15-30					
	23	Titanium Alloys	Pure 99.5 Ti	400Rm	25-70					
	24		α+β alloys	1050Rm	25-50					
H Hardened Material	25	Extra Hard Steel	Hardened & Tempered	45-50HRC	25-70	0.04	0.05	0.06	0.07	0.08
	26			51-55HRC	25-60	0.03	0.04	0.05	0.06	0.07
	27			56-62HRC	25-50	0.02	0.03	0.04	0.05	0.06

HTC Recommended Grades, Cutting Speed and Feed

Material Group	Material	Hardness Brinell HB	Strength (N-mm ²)	Vc[m/min]		fb[mm/rev]		fz[mm/tooth]		
				VTN	VTS	≤6mm	≤12mm	≤6mm	≤12mm	
K Cast Iron	Cast Iron	Grey Cast Iron	≤150	≤500	50-80	80-120	0.10-0.15	0.15-0.22	0.02-0.05	0.05-0.10
		Grey Cast Iron, Heat Treated	150-300	500-1000	50-80	80-120	0.10-0.15	0.15-0.22	0.02-0.05	0.05-0.10
	Copper	Spher. Graph. Cast Iron	≤200	≤700	50-80	80-120	0.10-0.15	0.15-0.22	0.02-0.05	0.05-0.10
N Non-Ferrous Metals	Aluminium/Magnesium	Short Chips, Brass, Bronze, Red Brass	≤200	≤700	100-300	—	0.06-0.10	0.10-0.30	0.03-0.06	0.06-0.10
		Aluminium, Magnesium Non-Alloy	≤100	≤350	100-400	100-400	0.10-0.25	0.25-0.30	0.03-0.06	0.06-0.10
		Aluminium, Wrought Alloy, Breaking Strain (A5) < 14%	≤180	≤600	100-400	100-400	0.10-0.25	0.25-0.30	0.03-0.06	0.06-0.10
		Aluminium, Wrought Alloy, Breaking Strain (A5) ≥ 14%	≤180	≤600	100-400	100-400	0.03-0.06	0.06-0.12	0.03-0.06	0.06-0.10
		Aluminium, Cast Alloy, Si<10%	≤180	≤600	100-300	100-400	0.10-0.25	0.25-0.30	0.03-0.06	0.06-0.10
K Plastic	Plastic	Aluminium, Cast Alloy, Si≥10%	≤180	≤600	—	100-300	0.10-0.25	0.25-0.30	0.03-0.06	0.06-0.10
		Thermo Plastics	—	—	60-120	60-120	0.10-0.25	0.25-0.30	0.03-0.06	0.06-0.10
		Thermosetting Plastic	—	—	60-100	60-100	0.10-0.25	0.25-0.30	0.03-0.06	0.06-0.10
		Fibre Reinforced Plastic	—	—	40-60	60-80	0.10-0.15	0.15-0.22	0.02-0.05	0.05-0.10

Vc - Cutting Speed [m/min]

fb (Drilling) - Feed per Revolution [mm/rev]

fz (Threading) - Feed per Tooth [mm/tooth]

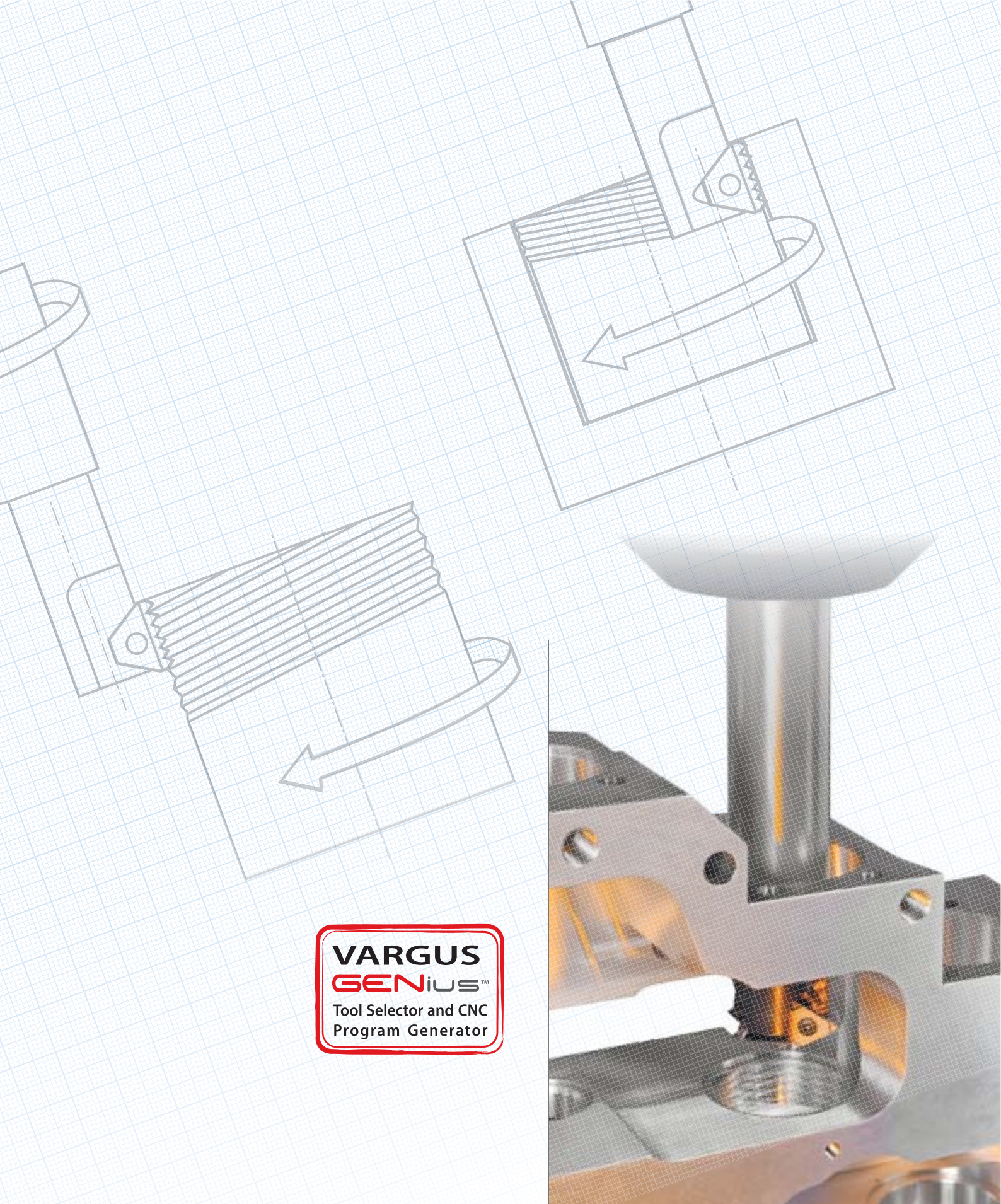

VARGUS
GENiUS™
Tool Selector and CNC
Program Generator

Thread Milling Technical Data

About Thread Milling

To perform a thread milling operation, a milling machine with three-axis control capable of helical interpolation is required. Helical interpolation is a CNC function producing tool movement along a helical path. This helical motion combines circular movement in one plane with a simultaneous linear motion in a plane perpendicular to the first. For example, the path from point A to point B (Fig. A) on the envelope of the cylinder combines a circular movement in the xy plane with a linear displacement in the z direction.

On most CNC systems this function can be executed in two different ways:

G02: Helical interpolation in a clockwise direction

G03: Helical interpolation in a counter-clockwise direction

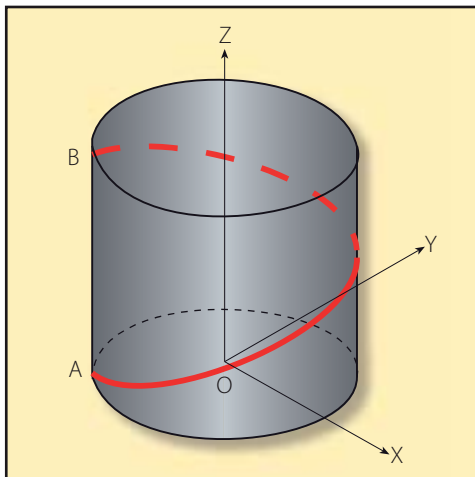

Fig. A

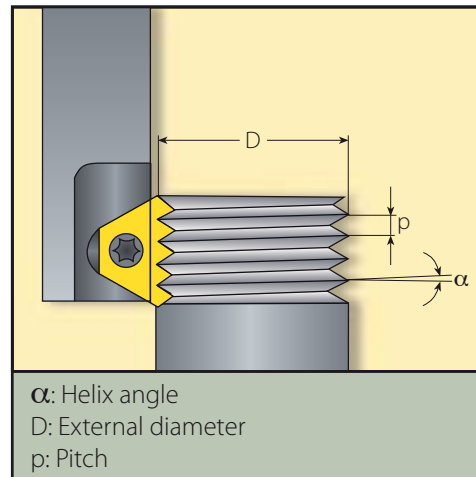

Fig. B

The thread milling operation (Fig. B) consists of circular rotation of the tool around its own axis together with an orbiting motion along the bore or workpiece circumference.

During one such orbit, the tool will shift vertically one pitch length. These movements combined with the insert geometry create the required thread form.

There are three acceptable ways of approaching the workpiece with the tool to initiate production of the thread:

- 1 Tangential Arc Approach**
- 2 Radial Approach**
- 3 Tangential Line Approach**

1 Tangential Arc Approach

With this method, the tool enters and exits the workpiece smoothly. No marks are left on the workpiece and there is no vibration, even with harder materials.

Although it requires slightly more complex programming than the radial approach (see below), this is the method recommended for machining the highest quality threads.

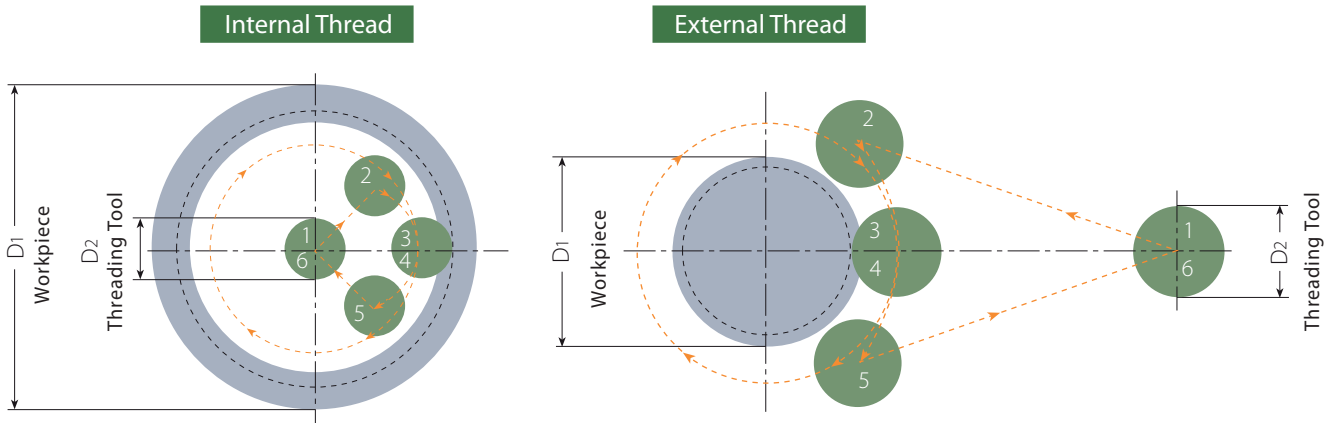

- 1-2:** Rapid approach
- 2-3:** Tool entry along tangential arc, with simultaneous feed along z-axis
- 3-4:** Helical movement during one full orbit (360°)
- 4-5:** Tool exit along tangential arc, with continuing feed along z-axis
- 5-6:** Rapid return

2 Radial Approach

This is the simplest method. There are two characteristics worth noting about the radial approach:

- 1.** A small vertical mark may be left at the entry (and exit) point. This is of no significance to the thread itself.
- 2.** When using this method with very hard materials, there may be a tendency of the tool to vibrate as it approaches the full cutting depth.

Note: Radial feed during entry to the full profile depth should only be $\frac{1}{3}$ of the subsequent circular feed.

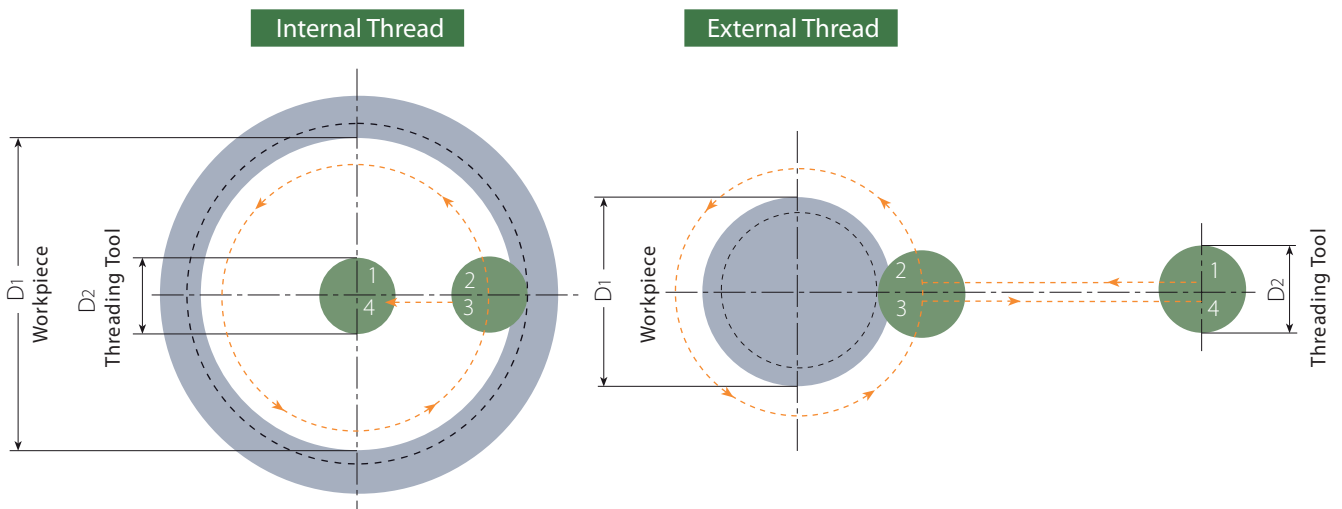

- 1-2:** Radial entry
- 2-3:** Helical movement during one full orbit (360°)
- 3-4:** Radial exit

3 Tangential Line Approach

This method is very simple, and has all of the advantages of the tangential arc method. However, it is applicable only with external threads.

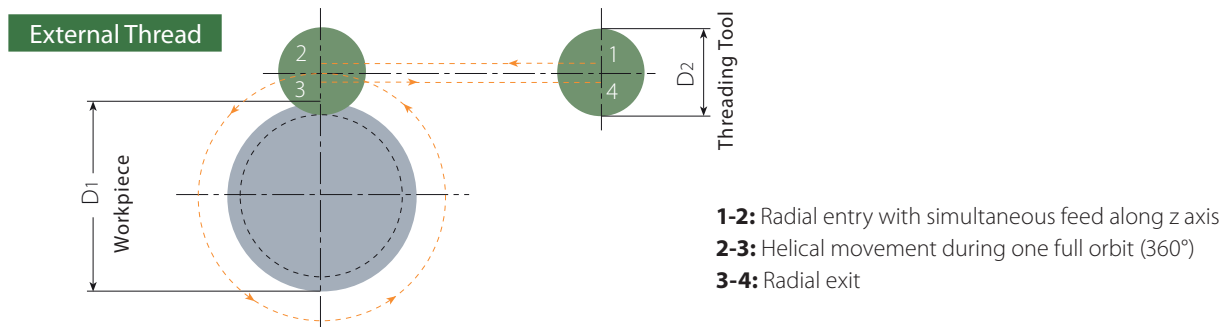

Preparing for the Thread Milling Operation

1 Calculation of Rotational Velocity and Feed at the Cutting Edge

$$N = \frac{1000 \times V}{\pi \times D_2}$$

$$V = \frac{N \times \pi \times D_2}{1000}$$

$$F_1 = N \times z \times f$$

N - Rotational Velocity [R.P.M.]
 V - Cutting Speed [m/min]
 D₂ - Toolholder Cutting Dia. [mm]
 F₁ - Tool Feed Rate at the Cutting Edge [mm/min]
 z - No. of Cutting Edges
 f - Feed per Tooth per Rotation [mm/tooth]

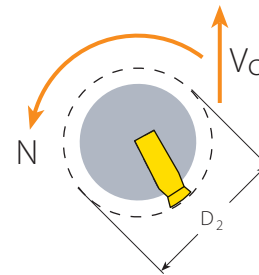

2 Calculation of Feed Rates at the Tool Center Line

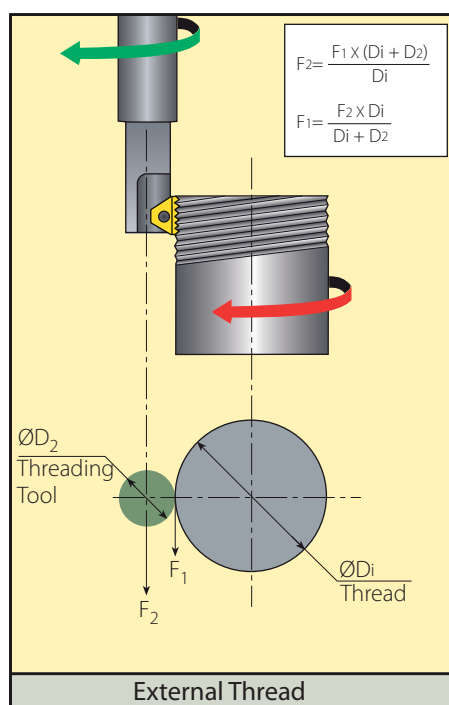
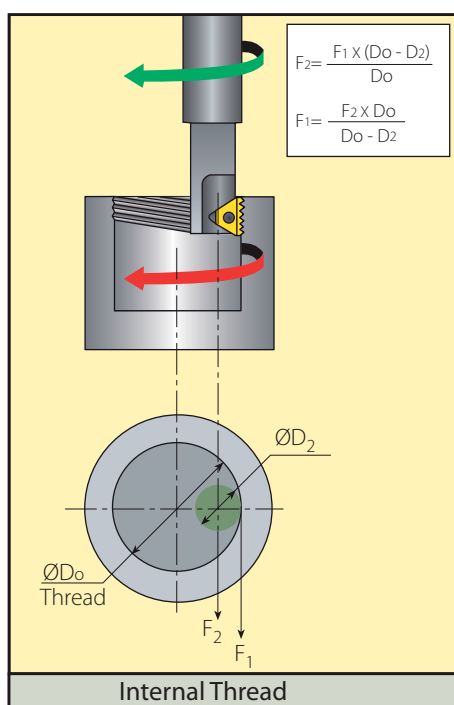

The equations define the relationship between feed rates at the cutting edge and at the tool center line. On most CNC machines the feed rate required for programming is that of the center-line of the tool. When dealing with linear tool movement the feed rate at the cutting edge and the center line are identical. This is not the case with circular tool movement.

List of "G" Codes (ISO) for CNC Program

Code	Description	Code	Description
%	Recognition code (ISO or EIA) + End of tape	H	Tool length compensation number
G00	Fast feed linear positioning	D	Tool radius compensation number
G01	Linear interpolation	X	X coordinate
G02	Circular/Helical interpolation CW	Y	Y coordinate
G03	Circular/Helical interpolation CCW	Z	Z coordinate
G40	Cutter radius compensation cancel	R	Radius of travel
G41	Cutter radius compensation left	I	X coordinate to center of starting arc travel
G42	Cutter radius compensation right	J	Y coordinate to center of starting arc travel
G43	Tool length compensation +	M3	Spindle forward rotation
G49	Tool length compensation cancel	M5	Spindle stop
G57	Work coordinate system selection	M30	Program end & rewind
G90	Absolute command relative to work coordinate origin	O	Program number
G91	Incremental command relative to tool position	N	Block number (can be avoided)
F	Feed mm/min	(Start of comment
S	Spindle speed RPM)	End of comment

CNC Program Sample (Thread: M60 x 1.5 x 20)

```

%
O0001 (TMINRH CLIMB CYCLES = 1)..... Program no.
(Fanuc 11M Controller.) ..... Remark
G90 G00 G57 X0 Y0..... Home (origin) set
G43 H10 Z0 M3 S946 ..... Tool length compensation-on and RPM set
G91 G00 X0 Y0 Z-20.272 ..... Go down in Z-axis
G41 D60 X9.459 Y-20.595 Z0 ..... Tool diameter compensation-on
G91 G03 X20.595 Y20.595 Z0.272 R20.595 F36 ..... Entrance by tangential arc
G91 G03 X0 Y0 Z1.500 I-30.054 J0 ..... Thread machining-HELICAL interpolation movement
G91 G03 X-20.595 Y20.595 Z0.272 R20.595 ..... Exit by tangential arc
G00 G40 X-9.459 Y-20.595 Z0 ..... Tool diameter compensation-off
G90 G49 G57 G00 Z200.000 M5 ..... Tool length compensation-off and RPM close
M30 ..... End of program
%
  
```

Recommendation:

At tool entry, set the Feed f [mm/tooth] to 70% lower than the threading Feed.

Example:

Threading Feed: 0.3[mm/tooth]
Tool entry Feed: 0.09[mm/tooth]

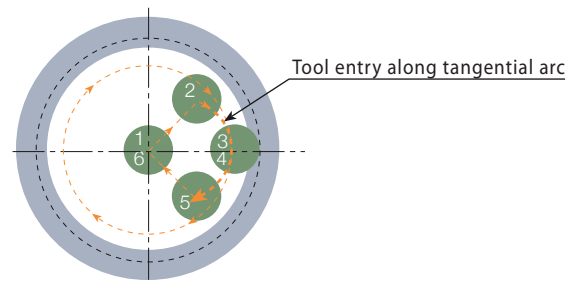

Minimum Bore Diameters for TM Standard line

Pitch mm		0.5	0.6	0.7	0.75 0.80	0.9	1.0	1.25	1.5	1.75	2.0		2.5	3.0	3.5	4.0	4.5	5.0	5.5		6.0											
Pitch tpi		48	44	36	32	28	26 24	20 19	18 16	14	13 12	11.5 11	10	9 8	7	6		5		4.5		4										
Toolholder Ordering Code	D2									Minimum Bore Diameter Di mm																						
TMMC 12-6.0	9.0	9.5	9.7	9.9	10.0	10.4	10.7	11.4	12.0																							
TMMC 20-6.0	9.0	9.5	9.7	9.9	10.0	10.4	10.7	11.4	12.0																							
TMMC 20-6.0 124/003	9.0	9.5	9.7	9.9	10.0	10.4	10.7	11.4	12.0																							
TMC 12-2	11.5	12.0	12.2	12.4	12.5	12.9	13.2	13.9	14.5	15.1																						
TMC 20-2	11.5	12.0	12.2	12.4	12.5	12.9	13.2	13.9	14.5	15.1																						
TMLC 25-2	11.5	12.0	12.2	12.4	12.5	12.9	13.2	13.9	14.5	15.1																						
TMSC 10-2	12.5	13.0	12.6	13.6	13.5	13.9	14.2	14.9	15.5	16.1																						
TMOOC 20-2	14.5	15.1	15.2	15.3	15.4	16.0	16.4	17.0	17.8	18.6																						
TMNC 16-3	15.5	16.0	16.2	16.4	16.5	16.9	17.2	17.9	18.5	19.0	19.5	20.0																				
TMC 16-3 124/001	15.5	16.0	16.2	16.4	16.5	16.9	17.2	17.9	18.5	19.0	19.5	20.0																				
TMC 16-3	17.0	17.6	17.8	18.0	18.2	18.7	19.0	19.6	20.0	20.5	21.0	21.5																				
BTMC 16-3B	17.0	17.6	17.8	18.0	18.2	18.7	19.0	19.6	20.0	20.5	21.0	21.5																				
TM2C 20-2	17.0	17.6	17.8	18.0	18.2	18.7	19.0	19.6	20.0	20.5																						
BTMC 20-3B	19.0	19.7	20.0	20.2	20.4	20.8	21.0	21.6	22.0	22.5	23.0	23.5																				
TMNC 20-3	19.0	19.7	20.0	20.2	20.4	20.8	21.0	21.6	22.0	22.5	23.0	23.5																				
TMC 20-3	20.0	20.7	21.0	21.2	21.4	21.8	22.0	22.6	23.0	23.5	24.0	24.5																				
TMOOC 20-3	20.0	20.7	21.0	21.2	21.4	21.8	22.0	22.6	23.0	23.5	24.0	24.5																				
BTMWC 25-3B	22.0	22.7	23.0	23.2	23.4	23.8	24.0	24.6	25.0	25.5	26.0	26.5																				
BTMLC 25-3B	22.0	22.7	23.0	23.2	23.4	23.8	24.0	24.6	25.0	25.5	26.0	26.5																				
TMLC 25-3	22.0	22.7	23.0	23.2	23.4	23.8	24.0	24.6	25.0	25.5	26.0	26.5																				
TMC 25-5 124/004	25.0	25.7	26.0	26.2	26.4	26.8	27.0	27.7	28.2	28.7	29.2	29.7	31.3	33.7	36.7	39.7	42.7															
TM2C 25-3	26.0	26.7	27.0	27.2	27.4	27.8	28.0	28.7	29.3	29.8	30.3	30.8																				
BTM2C 25-3B	26.0	26.7	27.0	27.2	27.4	27.8	28.0	28.7	29.3	29.8	30.3	30.8																				
TMC 25-5	30.0	30.7	31.0	31.2	31.4	31.8	32.0	32.8	33.5	34.1	34.6	35.6	36.6	39.0	42.0	45.0	48.0															
TMLC 25-5	30.0	30.7	31.0	31.2	31.4	31.8	32.0	32.8	33.5	34.1	34.6	35.6	36.6	39.0	42.0	45.0	48.0															
TMOOC 25-5	30.0	30.7	31.0	31.2	31.4	31.8	32.0	32.8	33.5	34.1	34.6	35.6	36.6	39.0	42.0	45.0	48.0															
TMC 32-6B	35.0								38.5	39.1	39.6	40.6	42.0	44.0	47.0	50.0	53.4	42.5	50.0	44.6	57.5	56.6										
TMC 32-5	37.0	38.0	38.2	38.4	38.6	39.1	39.5	40.4	41.0	41.5	42.0	43.0	44.0	46.5	49.0	52.0	55.5															
TMLC 32-5	37.0	38.0	38.2	38.4	38.6	39.1	39.5	40.4	41.0	41.5	42.0	43.0	44.0	46.5	49.0	52.0	55.5															
TMNC 32-5	37.0	38.0	38.2	38.4	38.6	39.1	39.5	40.4	41.0	41.5	42.0	43.0	44.0	46.5	49.0	52.0	55.5															
TMSH D38-16-2	38.0	38.5	38.7	38.9	39.0	39.6	40.0	41.0	42.0	43.0																						
TM2C 32-5	42.0	43.2	43.4	43.6	43.8	44.5	45.0	46.0	46.5	47.0	47.4	48.2	49.0	52.0	54.5	57.5	61.0															
TMVC 32-5	46.0																						62.5									
TMC 40-6B	46.0								49.5	50.1	50.6	51.6	53.0	55.0	55.2	55.6	55.0	52.5	54.0	54.5	57.5	56.6										
TMLC 40-6B	46.0								49.5	50.1	50.6	51.6	53.0	55.0	55.2	55.6	55.0	52.5	54.0	54.5	57.5	56.6										
TMSH D50-22-2	50.0	50.5	50.7	50.9	51.0	51.6	52.0	53.0	54.0	54.5																						
TMSH D50-22-3	50.0	50.5	50.7	50.9	51.0	51.6	52.0	53.0	54.0	54.5	55.0	55.5																				

Thread Milling
Technical Data

Minimum Bore Diameters for TM Standard line (con't)

Pitch mm	0.5	0.6	0.7	0.75 0.80	0.9	1.0	1.25	1.5	1.75	2.0		2.5	3.0	3.5	4.0	4.5	5.0	5.5		6.0											
Pitch tpi	48	44	36	32	28	26 24	20 19	18 16	14	13 12	11.5 11	10	9 8	7	6		5			4.5		4									
Toolholder Ordering Code	D2									Minimum Bore Diameter Di mm																					
TM2C 40-6B	52.0								56.0	56.2	56.5	57.0	59.0	61.5		63.0	64.0	66.0	67.0	67.6	69.0	70.0									
TMSH D63-22-3B	63.0	63.5	63.7	63.9	64.0	64.6	65.0	66.0	67.0	67.5	68.0	69.0																			
TMSH D63-22-5	63.0	63.5	63.7	63.9	64.0	64.6	65.0	66.0	67.0	67.5	68.0	69.0	70.0	72.0	73.0	74.0	75.0														
TMSH D63-22-6B	63.0								67.0	67.5	68.0	69.0	70.0	72.0	73.0	74.0	75.0	77.0	78.0	78.6	80.0	81.0									
TMSH D80-27-5	80.0	80.5	80.7	80.9	81.0	81.6	82.0	83.0	84.0	84.5	85.0	86.0	87.0	89.0	90.0	91.0	92.0														
TMSH D80-27-6B	80.0								84.0	84.5	85.0	86.0	87.0	89.0	90.0	91.0	92.0	94.0	95.0	95.6	97.0	98.0									
TMSH D100-32-5	100.0	100.5	100.7	100.9	101.0	101.6	102.0	103.0	104.0	104.5	105.0	106.0	107.0	109.0	110.0	111.0	112.0														
TMSH D100-32-6B	100.0								104.0	104.5	105.0	106.0	107.0	109.0	110.0	111.0	112.0	114.0	115.0	115.6	117.0	118.0									
TMSH D125-40-5	125.0	125.5	125.7	125.9	126.0	126.6	127.0	128.0	129.0	129.5	130.0	131.0	132.0	134.0	135.0	136.0	137.0														
TMSH D125-40-6B	125.0								129.0	129.5	130.0	131.0	132.0	134.0	135.0	136.0	137.0	139.0	140.0	140.6	142.0	143.0									

Coarse Pitch Tooling:

This table is not applicable to the Coarse Pitch system, which can thread mill bores smaller than those listed above.

See the Coarse Pitch section of the various thread standards.

Spare Parts for TM Standard Line



Insert Screw



IC	Holder	Holder Screw	Designation	Thread	Torx Key	Torx Size
6.0mm	TMMC...-6.0		SN7T	M2.2x0.45x5.0	K7T	T7
1/4"	TM.C...-2		SN2TM	M2.6x0.45x5.9	K2T	T8
3/8"	TM.C...-3, TMC...-3 124/...		SN3T, SN3TM	5-40UNCx8.8, 7.3	K3T	T10
3/8"B	BTM.C...-3B		SN3T	5-40UNCx8.8	K3T	T10
1/2"	TMC...-4 124/...		SN4TM, SA4TM	8-32UNCx9.8, 10.7	K4T	T20
5/8"	TM.C...-5, TMC...-5 124/...		SN5TM, SA5TM	M5x0.8x15.0	K5T	T25
3/4"B	TM.C...-6B		SM7T	M7x1.0x15.0	K30T	T30
1/4"	TMSH-D38-16-2	M8X1.25X35	SN2T	M2.6x0.45x6.5	HK2T	T8
1/4"	TMSH-D50-22-2	M10X1.50X35	SN2T	M2.6x0.45x6.5	HK2T	T8
3/8"	TMSH-D50-22-3	M10X1.50X35	SN3TM	5-40UNCx7.3	HK3T	T10
3/8"B	TMSH-D63-22-3B	M10X1.50X35	SN3TM	5-40UNCx7.3	HK3T	T10
5/8"	TMSH-D63-22-5	M10X1.50X35	SN5TM	M5x0.8x15.0	HK5T	T25
3/4"B	TMSH-D63-22-6B	M10X1.50X35	SM7T	M7x1.0x15.0	HK7T	T30
5/8"	TMSH-D80-27-5	M12X1.75X40	SN5TM	M5x0.8x15.0	HK5T	T25
3/4"B	TMSH-D80-27-6B	M12X1.75X40	SM7T	M7x1.0x15.0	HK7T	T30
5/8"	TMSH-D100-32-5	M16X2.00X40	SN5TM	M5x0.8x15.0	HK5T	T25
3/4"B	TMSH-D100-32-6B	M16X2.00X40	SM7T	M7x1.0x15.0	HK7T	T30
5/8"	TMSH-D125-40-5	M20X2.50X50	SN5TM	M5x0.8x15.0	HK5T	T25
3/4"B	TMSH-D125-40-6B	M20X2.50X50	SM7T	M7x1.0x15.0	HK7T	T30
1/4"	TMSC10-2		SN2TK	M2.6x0.45x5.9	K2T	T8
5/8"V	TMVC32-5		SN6T	M6x1.0x29.0	K6T	T20

Spare Parts for MiTM Line



Insert Screw



Insert Size	Holder	Holder Screw	Designation	Thread	Torx Key	Torx Size
19	RTMC...A		SLD3IP6	M3x0.5	KIP6	Torx+6
24	RTMC...M		SLD4IP8	M4x0.7	KIP8	Torx+8
25	RTMC...S RTMC-D...S		SLD4IP8	M4x0.7	KIP8	Torx+8
40	RTMC...L RTMC-D...L		SLD4IP8A SCD4IP8A	M4x0.7	KIP8	Torx+8
41	RTMC...B RTMC-D...B		SLD4IP8A SCD4IP8A	M4x0.7	KIP8	Torx+8
25	RTMC-D36-16-25S5	M8x1.25x35	SLD4IP8	M4x0.7	KIP8	Torx+8
	RTMC-D44-22-25S6	M10x1.50x35				
	RTMC-D52-27-25S8	M12x1.75x30				
40	RTMNC-D36-16-25S5	M8x1.25x35	SLD4IP8A SCD4IP8A	M4x0.7	KIP8	Torx+8
	RTMC-D44-22-40L6	M10x1.5x40				
	RTMC-D52-27-40L8	M12x1.75x40				
41	RTMNC-D45-22-40L6	M10x1.5x40	SLD4IP8A SCD4IP8A	M4x0.7	KIP8	Torx+8
	RTMC-D48-22-41B5	M10x1.5x40				
	RTMC-D58-27-41B6	M12x1.75x40				

Spare Parts for TMSD Line



Insert Screw

IC	Holder	Holder Screw	Designation	Thread	Torx Key	Blade	Handle	Torx Size
7V	GMC...-7-3 CGMC...-7-3		SN2T8-M1	M3.0x0.5x9	K2T			T8
9V	GMC...-9-3 CGMC...-9-3		SN2T15-M2	M4x0.7x13.5	-	Blade T15-1/4	Smart Handle 1/4x2	T15
11V	GMC...-11-3 CGMC...-11-3		SN4T20-M3	M55x0.8x15.5	-	Blade T20-1/4	Smart Handle 1/4x2	T20
1/4"U, 1/4"A	TM.C...-2U CTMC...-2U or 2A		SN2T	M2.6x0.45x6.5	HK2T			T8
3/8"U, 3/8"A	TM.C...-3U TM.C-D...-3U or 3A		SN3T	5-40UNCx8.8	HK3T			T10
1/2"U	TM.C...-4U TM.C-D...-4U		SA4T	8-32UNCX14.0	HK4T			T20
5.0L	TM.C...-5L CTMC...-5L		SN5LTR	M2.2X0.45X5.0	K7T			T7
3/8"L	TM.C...-3 CTMC...-3L		SN3T SA3T	5-40UNCx8.8 5-40UNCx11.3	HK3T			T10
5/8"V	TM.SC-D...-5V..		SA5T	M5x0.8x22.0	HK5T			T25
3/8"U	TM4SC-D42-16-3U	SA5T-C5 (M8x1.25x28) Holder Screwdriver TK5T	SN3T	5-40UNCx8.8	HK3T			T10
	TM5SC-D48-22-3U	M10x1.50x35						
	TM6SC-D56-22-3U	M10x1.50x35						
1/2"U	TM6SC-D88-27-4U	M12x1.75x40	SA4T	8-32UNCX14.0	HK4T			T20
	TM7SC-D98-32-4U	M16x2.0x40						
3/8"L	TM7SC-D80-32-3L	M16x2.0x40	SA3T	5-40UNCx11.3	HK3T			T10
	TM5SC-D48-22-3L-ABUT	M10x1.50x35						
	TM6SC-D58-27-3L-ABUT	M12x1.75x40						
5/8"V	TM6SC-D88-32-5V6-ABUT	M16x2.0x40	SA5T	M5x0.8x22.0	HK5T			T25
	TM6SC-D88-32-5V8-ABUT	M16x2.0x40						

Troubleshooting

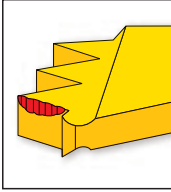
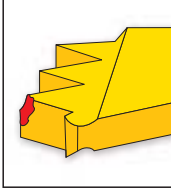
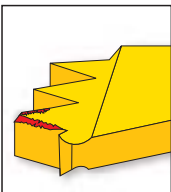
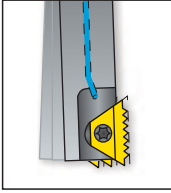
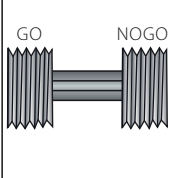
	Problem	Possible Cause	Solution
	Increased insert flank wear	Cutting speed too high -----> Chip is too thin -----> Insufficient coolant ----->	Reduce cutting speed/use coated insert Increase feed rate Increase coolant flow rate
	Chipping of cutting edge	Chip is too thick -----> Vibration ----->	Reduce feed rate Use the tangential arc method Increase RPM Check stability
	Material build up on the cutting edge	Incorrect cutting speed -----> Unsuitable carbide grade ----->	Change cutting speed Use a coated carbide grade
	Chatter / Vibration	Feed rate is too high -----> Profile is too deep -----> Thread length is too long ----->	Reduce the feed Execute two passes, each with increased cutting depth Execute two passes, each cutting only half the thread length Execute two passes, each cutting only half the thread length
	Insufficient thread accuracy	Tool deflection ----->	Reduce feed rate Execute a "zero" cut

The Thread Milling Handbook

The Thread Milling Handbook:

Your everyday guide to the theory and implementation of the thread milling system.

Download it for free at www.vargus.com

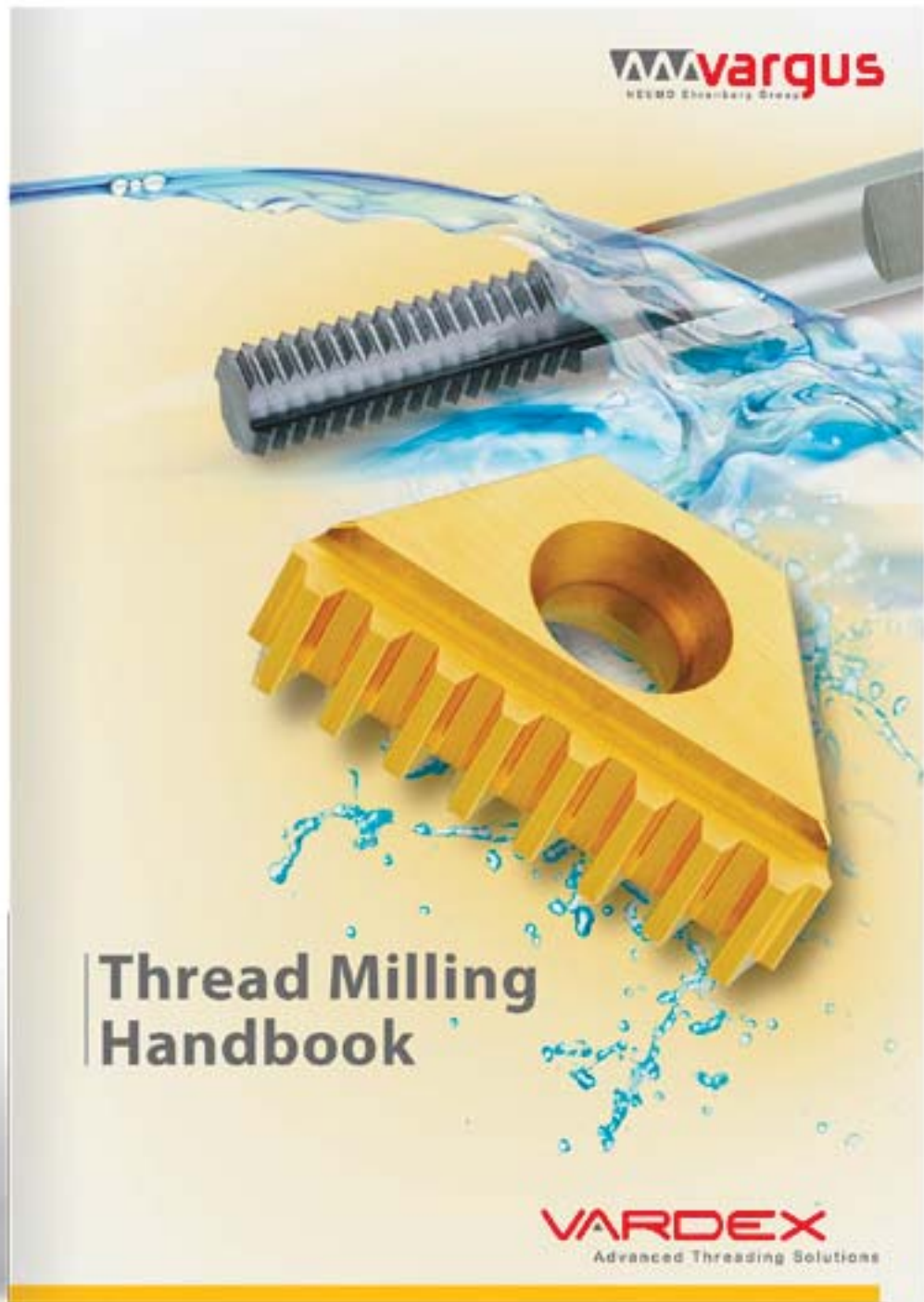

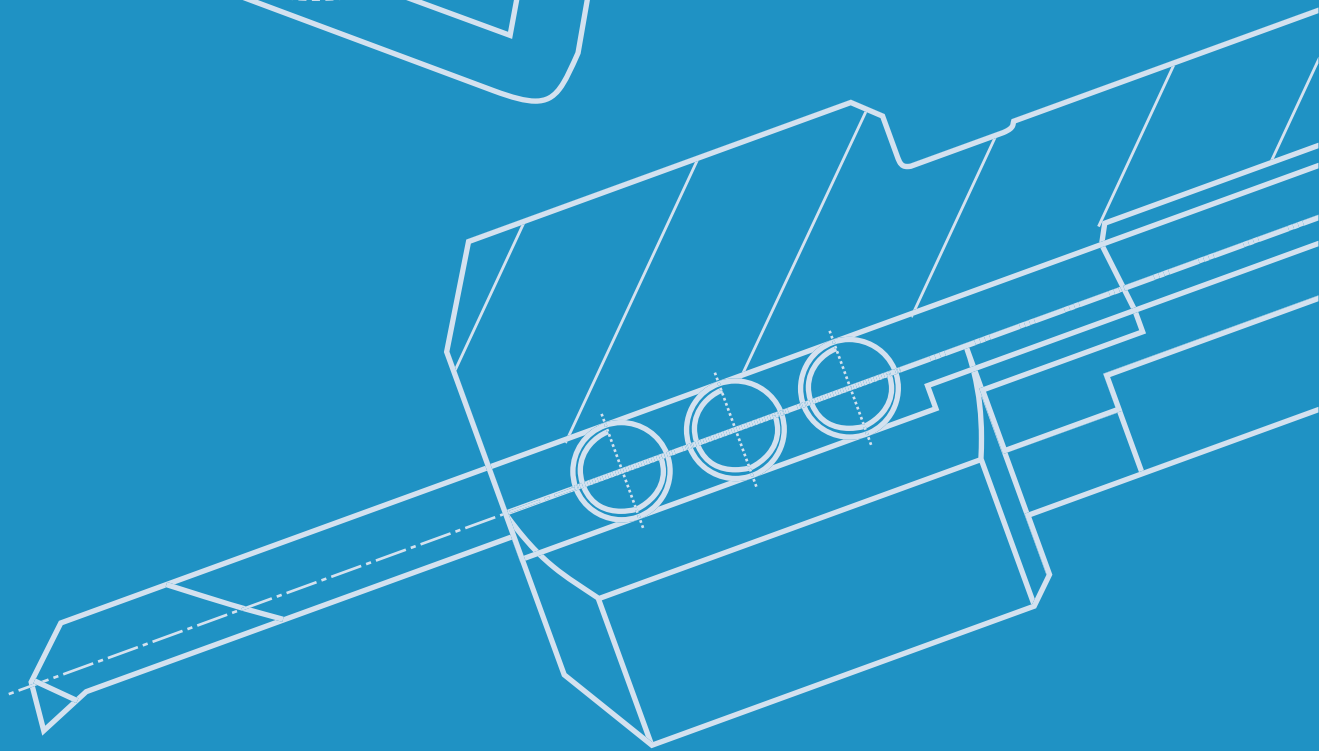
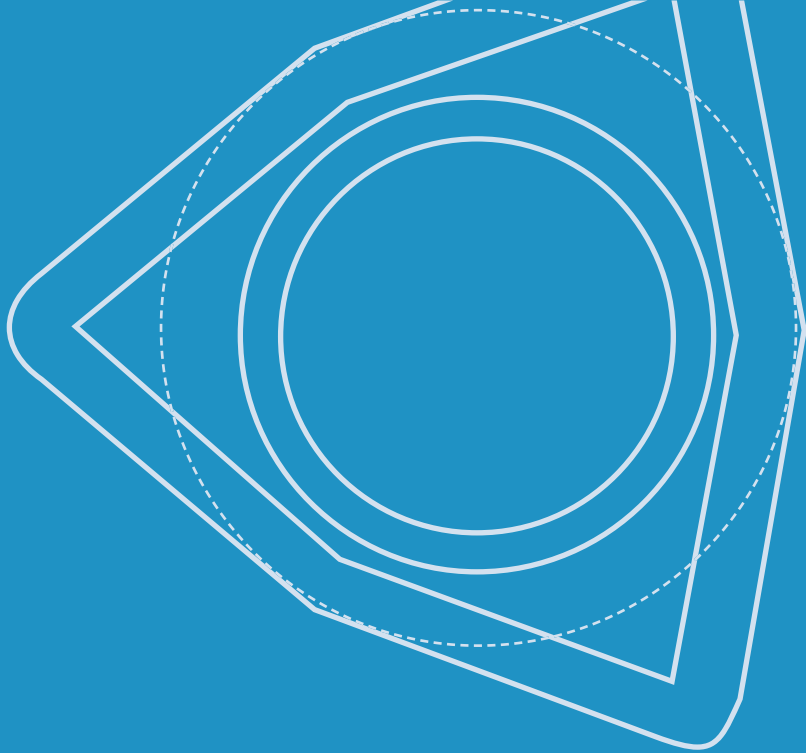

MINIPRO

■ PowerBore Inserts	383
■ Micro (Boring & Grooving) Inserts	385
■ Toolholders (PowerBore & Micro)	395
■ Technical Data	403

Vardex Ordering Code System

PowerBore Inserts

T 1	D 2	0 3	W 4	41 5	14 6	VTX 7
1 - Insert Shape C - Diamond 80 deg. T - Triangle W - Trigon 80 deg.	2 - Clearance Angle C - 7 deg. D - 15 deg.	3 - Tolerance Class 0 - Special Tolerance Class		4 - Insert Type W - Hole + Countersink		
5 - Insert Dimension 40 - IC 0.156" - Thickness-1.02mm 41 - IC 0.160" - Thickness-1.19mm 42 - IC 0.156" - Thickness-1.57mm 50 - IC 0.187" - Thickness-2.44mm	6 - Corner Radius 11 - R 0.05 12 - R 0.18 13 - R 0.20 14 - R 0.38	7 - Carbide Grade VTX				

Micro Boring Inserts - Double Ended

6.0 1	S 2	I 3	R 4	0.2 5	M 6	-	Bore 7	-	1 8	VMX 9
1 - Insert Dia. 3.0 - 3.0mm 4.0 - 4.0mm 6.0 - 6.0mm 8.0 - 8.0mm 10.0 - 10.0mm	2 - Insert Style S - Micro Insert		3 - Type of Insert I - Internal		4 - RH or LH R - Right Hand Insert L - Left Hand Insert		5 - Corner Radius 0.2			
6 - Tool Length U - Ultra Short S - Short M - Medium L - Long	7 - Tool Application Bore - Boring Copy - Boring Copy Chamfer - Boring Chamfer Back - Back Edge 3527, 3537, 3547 - Long Nose BD - Bore Drill			8 - Front Relief 1 - With Relief 0 - Without Relief		9 - Carbide Grade VMX				

Micro Grooving Inserts - Double Ended

4.0 1	S 2	I 3	R 4	0.7 5	A 6	-	D471/D472 7	-	1.4 8	VMX 9
1 - Insert Dia. 3.0 - 3.0 mm 4.0 - 4.0 mm 6.0 - 6.0 mm 8.0 - 8.0 mm 10.0 - 10.0 mm	2 - Insert Style S - Micro Insert		3 - Type of Insert I - Internal		4 - RH / LH Insert R - Right Hand Insert L - Left Hand Insert		5 - Groove Std. Width 0.9 - 2.15 (mm)			
6 - Insert Length A - Axially S - Short M - Medium L - Long	7 - Groove Standard DIN 471 DIN 472 DIN 7993 DIN 76SH, DIN 76ST DIN 3770S, DIN 3770D DIN 471/472 - Face Grooving			8 - Groove Depth 0.5 - 1.5 (mm)		9 - Carbide Grade VMX				

Boring & Grooving Inserts

Internal

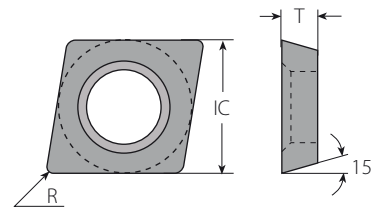
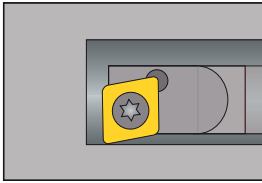

CD0W

CD0W Inserts

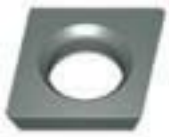

Insert Size	Ordering Code	Dimensions mm		Spare Parts
		R	T	
.156"	CD0W4011...	0.05	1.02	Insert Screw  VS01
	CD0W4012...	0.18	1.02	
	CD0W4014...	0.38	1.02	

Internal

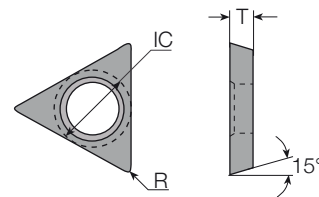
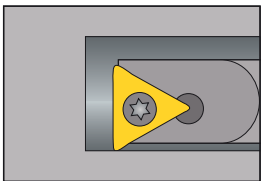

TD0W

TD0W Inserts



Insert Size	Ordering Code	Dimensions mm		Spare Parts
		R	T	
.160"	TD0W4111...	0.05	1.19	Insert Screw  VS01, VS40
	TD0W4112...	0.18	1.19	
	TD0W4114...	0.38	1.19	

Internal

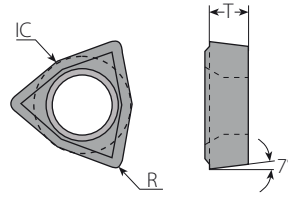
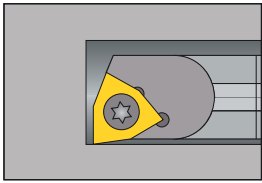

WCOW 4213, 4214

WCOW Inserts



Insert Size	Ordering Code	Dimensions mm		Spare Parts
		R	T	
.156"	WCOW4213...	0.20	1.57	Insert Screw  VS40
	WCOW4214...	0.38	1.57	

Internal

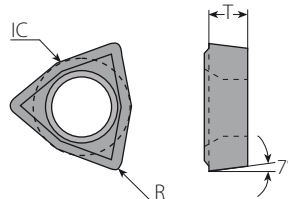
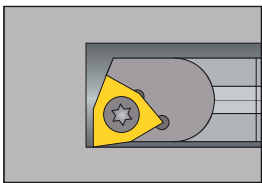

TDOW

WCOW Inserts



Insert Size	Ordering Code	Dimensions mm		Spare Parts
		R	T	
.187"	WCOW5013...	0.20	2.44	Insert Screw  VS41
	WCOW5014...	0.38	2.44	

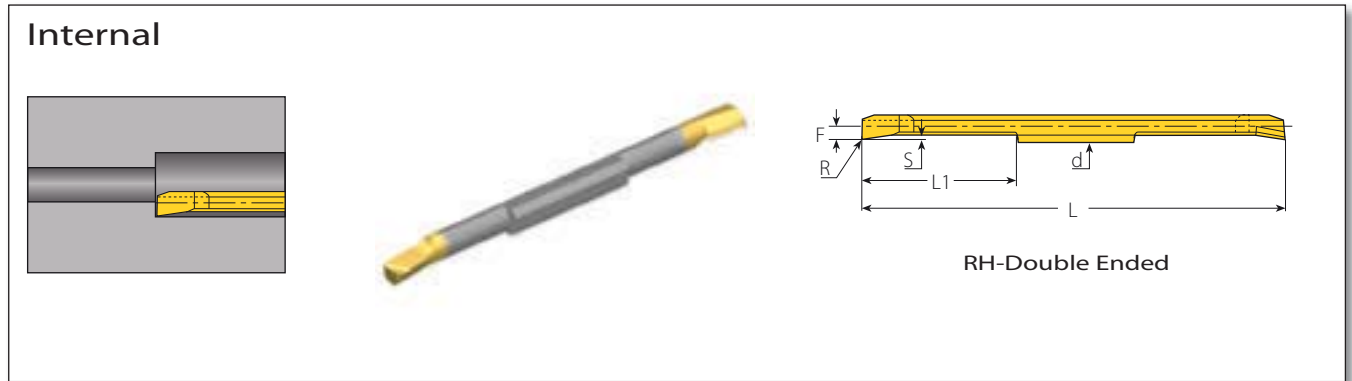

Micro - Double Ended

Insert Dia. d mm	Ordering Code RH	Dimensions mm					Min. Bore Dia. mm	Toolholder
		R	L1	L	S	F		
3.0	3.0SIR0.1U-Bore-1...	0.1	6	36	0.56	1.36	3.2	SMC..-3.0
	3.0SIR0.1S-Bore-1...	0.1	9	36	0.56	1.36		
	3.0SIR0.2S-Bore-1...	0.2	9	36	0.66	1.42		
	3.0SIR0.2M-Bore-1...	0.2	16	50	0.66	1.42		
4.0	4.0SIR0.2S-Bore-1...	0.2	9	36	0.66	1.92	4.2	SMC..-4.0
	4.0SIR0.2M-Bore-1...	0.2	16	50	0.66	1.92		
	4.0SIR0.2L-Bore-1...	0.2	21	60	0.66	1.92		
6.0	6.0SIR0.2S-Bore-1...	0.2	9	36	0.77	2.92	6.2	SMC..-6.0
	6.0SIR0.2M-Bore-1...	0.2	16	50	0.77	2.92		
	6.0SIR0.2L-Bore-1...	0.2	21	60	0.77	2.92		
8.0	8.0SIR0.2S-Bore-1...	0.2	12	54	0.82	3.92	8.2	SMC..-8.0
	8.0SIR0.2M-Bore-1...	0.2	20	70	0.82	3.92		
	8.0SIR0.2L-Bore-1...	0.2	28	86	0.82	3.92		
10.0	10.0SIR0.2S-Bore-1...	0.2	15	60	1.00	4.92	10.2	SMC..-10.0
	10.0SIR0.2M-Bore-1...	0.2	25	80	1.00	4.92		
	10.0SIR0.2L-Bore-1...	0.2	35	100	1.00	4.92		

Internal

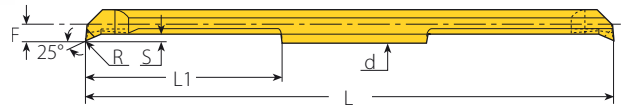
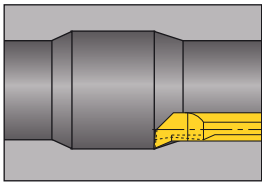

RH-Double Ended

Micro - Double Ended

Insert Dia.	Ordering Code	Dimensions mm					Min. Bore Dia.	Toolholder
d mm	RH	R	L1	L	S	F	mm	
4.0	4.0SIR0.2S-Copy-1...	0.2	9	36	1.0	1.92	4.2	SMC...-4.0
	4.0SIR0.2M-Copy-1...	0.2	16	50	1.0	1.92		
	4.0SIR0.2L-Copy-1...	0.2	21	60	1.0	1.92		
6.0	6.0SIR0.2S-Copy-1...	0.2	9	36	1.3	2.92	7.0	SMC...-6.0
	6.0SIR0.2M-Copy-1...	0.2	16	50	1.3	2.92		
	6.0SIR0.2L-Copy-1...	0.2	21	60	1.3	2.92		

Micro Boring - Chamfer

Internal

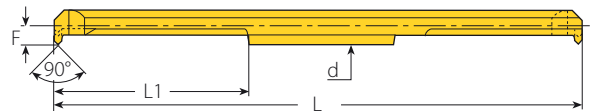
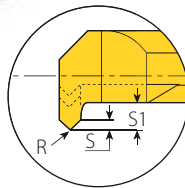
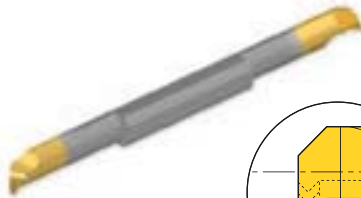
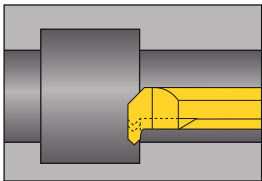

RH-Double Ended

Micro - Double Ended

Insert Dia.	Ordering Code	Dimensions mm						Min. Bore Dia.	Toolholder
d mm	RH	R	L1	L	F	S1	S	mm	
4.0	4.0SIR0.2S-Chamfer-0...	0.2	9	36	1.92	1.0	0.40	4.2	SMC...-4.0
	4.0SIR0.2M-Chamfer-0...	0.2	16	50	1.92	1.0	0.40		
	4.0SIR0.2L-Chamfer-0...	0.2	21	60	1.92	1.0	0.40		
6.0	6.0SIR0.2S-Chamfer-0...	0.2	9	36	2.92	1.2	0.70	6.2	SMC...-6.0
	6.0SIR0.2M-Chamfer-0...	0.2	16	50	2.92	1.2	0.70		
	6.0SIR0.2L-Chamfer-0...	0.2	21	60	2.92	1.2	0.70		

Boring & Grooving Inserts

Micro Boring - Long Nose

MINIPRO

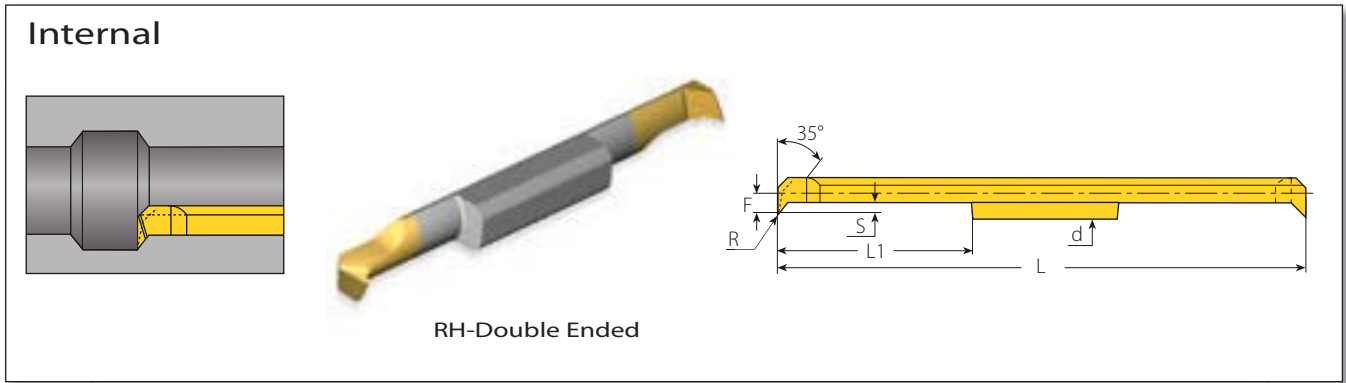

Micro - Double Ended

Insert Dia.	Ordering Code	Dimensions mm					Min. Bore Dia.	Toolholder
d mm	RH	R	L1	L	S	F	mm	
6.0	6.0SIR0.2S-3527-1...	0.2	9	36	2.7	2.92	6.9	SMC...-6.0
	6.0SIR0.2M-3527-1...	0.2	16	50	2.7	2.92		
	6.0SIR0.2L-3527-1...	0.2	21	60	2.7	2.92		
8.0	8.0SIR0.2S-3537-1...	0.2	12	54	3.7	3.92	8.9	SMC...-8.0
	8.0SIR0.2M-3537-1...	0.2	20	70	3.7	3.92		
	8.0SIR0.2L-3537-1...	0.2	28	86	3.7	3.92		
10.0	10.0SIR0.2S-3547-1...	0.2	15	60	4.7	4.92	10.8	SMC...-10.0
	10.0SIR0.2M-3547-1...	0.2	25	80	4.7	4.92		
	10.0SIR0.2L-3547-1...	0.2	35	100	4.7	4.92		

Micro Boring - Back Boring

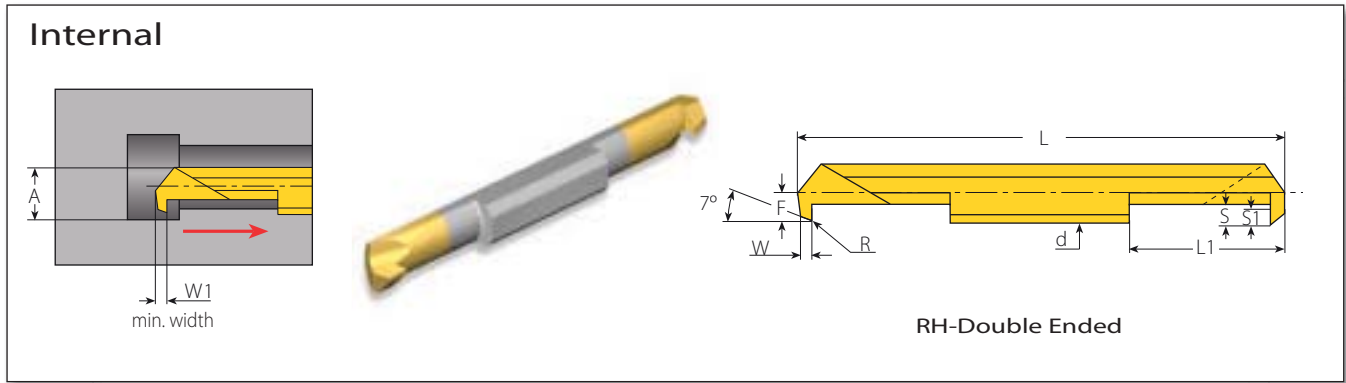

Micro - Double Ended

Insert Dia. d mm	Ordering Code RH	R	L1	L	Dimensions mm						Min. Bore Dia. mm	Toolholder
3.0	3.0SIR0.2S-Back-1...	0.05	9	36	3.42	1.5	1.81	0.8	0.6	1.42	3.2	SMC...-3.0
	3.0SIR0.2M-Back-1...	0.05	16	50								
4.0	4.0SIR0.2S-Back-1...	0.05	9	36	4.44	2.0	2.34	1.3	1.0	1.92	4.2	SMC...-4.0
	4.0SIR0.2M-Back-1...	0.05	16	50								
	4.0SIR0.2L-Back-1...	0.05	21	60								
6.0	6.0SIR0.2S-Back-1...	0.05	9	36	6.44	2.0	2.46	1.9	1.6	2.92	6.2	SMC...-6.0
	6.0SIR0.2M-Back-1...	0.05	16	50								
	6.0SIR0.2L-Back-1...	0.05	21	60								

Micro Boring - Bore Drill

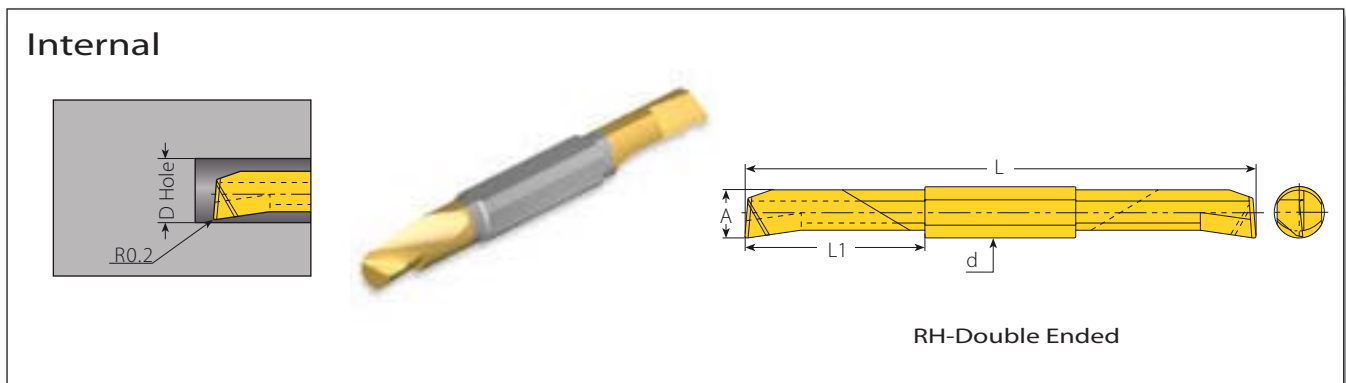

Micro - Double Ended

Insert Dia. d mm	Ordering Code RH	L1	L	A	Min. Bore Dia. mm	Toolholder
4.0	4.0SIR0.2M-BD-1...	16	50	3.53	3.74	SMC...-4.0
6.0	6.0SIR0.2M-BD-1...	16	50	5.20	5.80	SMC...-6.0
	6.0SIR0.2L-BD-1...	21	60			
8.0	8.0SIR0.2S-BD-1...	12	54	6.90	7.80	SMC...-8.0
	8.0SIR0.2M-BD-1...	20	70			
	8.0SIR0.2L-BD-1...	28	86			

Boring & Grooving Inserts

DIN 472 Retaining Ring Grooves for Bores

MINIPRO

Internal

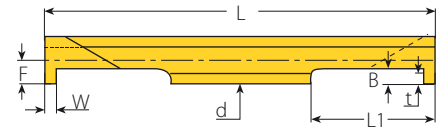
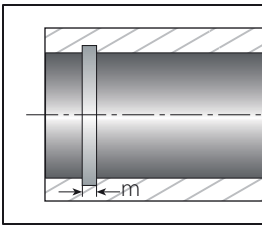

RH-Double Ended

Micro - Double Ended

Insert Dia. d mm	Ordering Code	Groove Std.		Dimensions mm					Min. Bore Dia. mm	Toolholder
		m (H13)	W	L1	L	B	t	F		
3.0	3.0SIR0.90S-D472-0.5...	0.90	0.99	9.0	36.0	0.8	0.5	1.40	3.2	SMC...-3.0
	3.0SIR0.90M-D472-0.5...	0.90	0.99	16.0	50.0					
	3.0SIR1.10S-D472-0.5...	1.10	1.19	9.0	36.0					
	3.0SIR1.10M-D472-0.5...	1.10	1.19	16.0	50.0					
4.0	4.0SIR0.90S-D472-1.1...	0.90	0.99	9.0	36.0	1.4	1.1	1.90	4.1	SMC...-4.0
	4.0SIR0.90M-D472-1.1...	0.90	0.99	16.0	50.0					
	4.0SIR0.90L-D472-1.1...	0.90	0.99	21.0	60.0					
	4.0SIR1.10S-D472-1.1...	1.10	1.19	9.0	36.0					
	4.0SIR1.10M-D472-1.1...	1.10	1.19	16.0	50.0					
	4.0SIR1.10L-D472-1.1...	1.10	1.19	21.0	60.0					
	4.0SIR1.30S-D472-1.1...	1.30	1.39	9.0	36.0					
	4.0SIR1.30M-D472-1.1...	1.30	1.39	16.0	50.0					
	4.0SIR1.30L-D472-1.1...	1.30	1.39	21.0	60.0					
	4.0SIR1.60S-D472-1.1...	1.60	1.69	9.0	36.0					
	4.0SIR1.60M-D472-1.1...	1.60	1.69	16.0	50.0					
	4.0SIR1.60L-D472-1.1...	1.60	1.69	21.0	60.0					
6.0	6.0SIR0.90S-D472-1.5...	0.90	0.99	9.0	36.0	1.8	1.5	2.90	6.1	SMC...-6.0
	6.0SIR0.90M-D472-1.5...	0.90	0.99	16.0	50.0					
	6.0SIR0.90L-D472-1.5...	0.90	0.99	21.0	60.0					
	6.0SIR1.10S-D472-1.5...	1.10	1.19	9.0	36.0					
	6.0SIR1.10M-D472-1.5...	1.10	1.19	16.0	50.0					
	6.0SIR1.10L-D472-1.5...	1.10	1.19	21.0	60.0					
	6.0SIR1.30S-D472-1.5...	1.30	1.39	9.0	36.0					
	6.0SIR1.30M-D472-1.5...	1.30	1.39	16.0	50.0					
	6.0SIR1.30L-D472-1.5...	1.30	1.39	21.0	60.0					
	6.0SIR1.60S-D472-1.5...	1.60	1.69	9.0	36.0					
	6.0SIR1.60M-D472-1.5...	1.60	1.69	16.0	50.0					
	6.0SIR1.60L-D472-1.5...	1.60	1.69	21.0	60.0					
	6.0SIR1.85S-D472-1.5...	1.85	1.94	9.0	36.0					
	6.0SIR1.85M-D472-1.5...	1.85	1.94	16.0	50.0					
	6.0SIR1.85L-D472-1.5...	1.85	1.94	21.0	60.0					
	6.0SIR2.15S-D472-1.5...	2.15	2.24	9.0	36.0					
	6.0SIR2.15M-D472-1.5...	2.15	2.24	16.0	50.0					
	6.0SIR2.15L-D472-1.5...	2.15	2.24	21.0	60.0					

DIN 472 Retaining Ring Grooves for Bores (con't)

MINIPRO

Internal

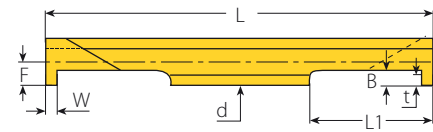
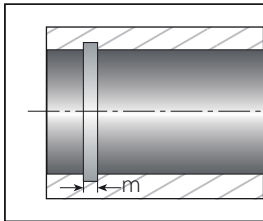

RH-Double Ended

Micro - Double Ended

Insert Dia. d mm	Ordering Code	Groove Std.		Dimensions mm					Min. Bore Dia. mm	Toolholder
		m (H13)	W	L1	L	B	t	F		
8.0	8.0SIR1.10M-D472-2.0...	1.10	1.19	20	70	2.5	2.0	3.9	8.4	SMC.-8.0
	8.0SIR1.30M-D472-2.0...	1.30	1.39	20	70	2.5	2.0			
	8.0SIR1.60M-D472-2.5...	1.60	1.69	20	70	3.0	2.5			
	8.0SIR1.85M-D472-2.5...	1.85	1.94	20	70	3.0	2.5			
	8.0SIR2.15M-D472-3.0...	2.15	2.24	20	70	3.5	3.0			
	8.0SIR2.65M-D472-3.5...	2.65	2.74	20	70	4.0	3.5			
	8.0SIR3.15M-D472-3.5...	3.15	3.28	20	70	4.0	3.5			
10.0	10.0SIR1.30M-D472-3.5...	1.30	1.39	25	80	4.0	3.5	4.9	10.4	SMC.-10.0
	10.0SIR1.60M-D472-3.5...	1.60	1.69	25	80					
	10.0SIR1.85M-D472-3.5...	1.85	1.94	25	80					
	10.0SIR2.15M-D472-3.5...	2.15	2.24	25	80					
	10.0SIR2.65M-D472-3.5...	2.65	2.74	25	80					
	10.0SIR3.15M-D472-3.5...	3.15	3.28	25	80					
	10.0SIR4.15M-D472-3.5...	4.15	4.28	25	80					
10.0SIR5.15M-D472-3.5...	5.15	5.28	25	80						

Internal

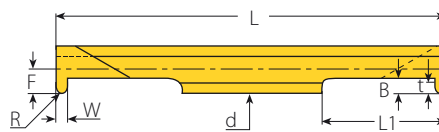
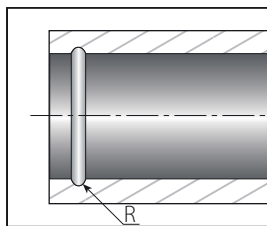

RH-Double Ended

Micro (Partial Profile) - Double Ended

Insert Dia. d mm	Ordering Code	Groove Std.		Dimensions mm						Min. Bore Dia. mm	Toolholder
		R	W	L1	L	B	t	F			
3.0	3.0SIR0.4S-D7993-0.6...	0.40	0.80	9.0	36.0	0.8	0.6	1.40	3.2	SMC...-3.0	
	3.0SIR0.4M-D7993-0.6...	0.40	0.80	16.0	50.0						
4.0	4.0SIR0.4S-D7993-0.6...	0.40	0.80	9.0	36.0	0.9	0.6	1.90	4.1	SMC...-4.0	
	4.0SIR0.4M-D7993-0.6...	0.40	0.80	16.0	50.0						
	4.0SIR0.4L-D7993-0.6...	0.40	0.80	21.0	60.0						
	4.0SIR0.6S-D7993-0.8...	0.60	1.20	9.0	36.0	1.1	0.8				
	4.0SIR0.6M-D7993-0.8...	0.60	1.20	16.0	50.0						
	4.0SIR0.6L-D7993-0.8...	0.60	1.20	21.0	60.0	1.4	1.1				
	4.0SIR0.9S-D7993-1.1...	0.90	1.80	9.0	36.0						
	4.0SIR0.9M-D7993-1.1...	0.90	1.80	16.0	50.0						
6.0	4.0SIR0.9L-D7993-1.1...	0.90	1.80	21.0	60.0	1.4	1.1	2.90	6.1	SMC...-6.0	
	6.0SIR0.9S-D7993-1.1...	0.90	1.80	9.0	36.0						
	6.0SIR0.9M-D7993-1.1...	0.90	1.80	16.0	50.0						
	6.0SIR0.9L-D7993-1.1...	0.90	1.80	21.0	60.0	1.5	1.2				
	6.0SIR1.0S-D7993-1.2...	1.00	2.00	9.0	36.0						
	6.0SIR1.0M-D7993-1.2...	1.00	2.00	16.0	50.0						
	6.0SIR1.0L-D7993-1.2...	1.00	2.00	21.0	60.0	1.6	1.3				
	6.0SIR1.1S-D7993-1.3...	1.10	2.20	9.0	36.0						
6.0SIR1.1M-D7993-1.3...	1.10	2.20	16.0	50.0							
6.0SIR1.1L-D7993-1.3...	1.10	2.20	21.0	60.0	2.5	2.0					
8.0SIR0.9M-D7993-2.0...	0.90	1.80	20.0	70.0							
8.0SIR1.1M-D7993-2.0...	1.10	2.20	20.0	70.0							
8.0	8.0SIR1.4M-D7993-2.0...	1.40	2.80	20.0	70.0	3.4	2.9	4.90	10.4	SMC...-10.0	
	10.0SIR1.4M-D7993-2.9...	1.40	2.80	25.0	80.0						
	10.0SIR1.8M-D7993-2.9...	1.80	3.60	25.0	80.0						

Internal

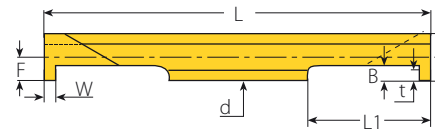
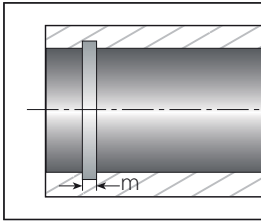

RH-Double Ended

Micro - Double Ended

Insert Dia. d mm	Ordering Code	Groove Std.		Dimensions mm					Min. Bore Dia. mm	Toolholder
		m (H13)	W	L1	L	B	t	F		
6.0	6.0SIR1.6S-D3770S-1.5...	1.6	1.98	9.0	36.0	1.8	1.5	2.9	6.1	SMC.-6.0
	6.0SIR1.6M-D3770S-1.5...	1.6	1.98	16.0	50.0					
	6.0SIR1.6L-D3770S-1.5...	1.6	1.98	21.0	60.0					
	6.0SIR2.0S-D3770D-1.8...	2.0	2.38	9.0	36.0	2.0	1.8	2.9		
	6.0SIR2.0M-D3770D-1.8...	2.0	2.38	16.0	50.0					
	6.0SIR2.0L-D3770D-1.8...	2.0	2.38	21.0	60.0					

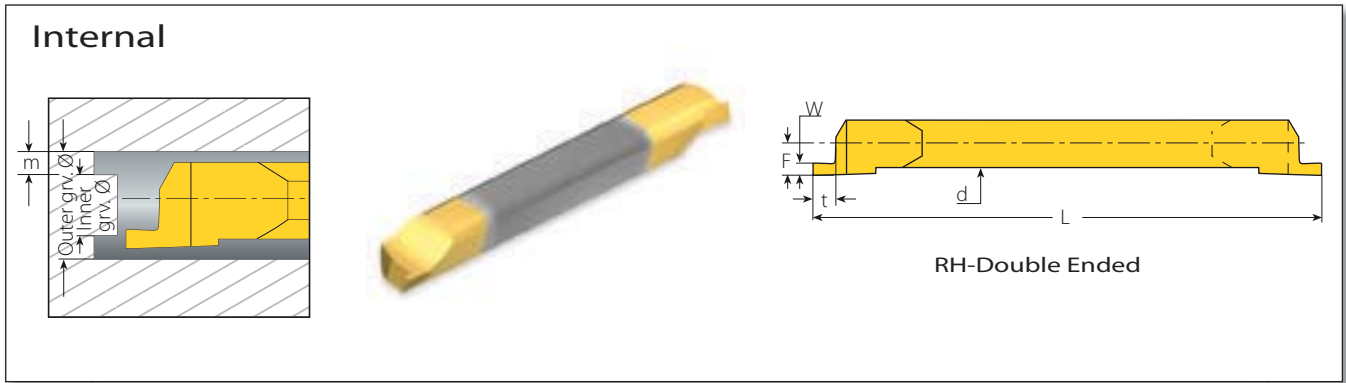

Micro (Partial Profile) - Double Ended

Insert Dia. d mm	Ordering Code RH	Groove Std.			Dimensions mm			Sleeve	Inner Groove Ø	Outer Groove Ø
		m (H13)	W	t	L	F				
4.0	4.0SIR0.7A-D471/472-1.4...	0.70	0.77	1.4	50	1.40	SMC..-4.0	3.50	5.00	
	4.0SIR0.8A-D471/472-1.5...	0.80	0.87	1.5				3.40	5.20	
	4.0SIR0.9A-D471/472-1.6...	0.90	0.97	1.6				3.30	5.30	
	4.0SIR1.1A-D471/472-1.8...	1.10	1.19	1.8				3.10	5.50	
	4.0SIR1.3A-D471/472-2.0...	1.30	1.39	2.0				2.90	5.70	
	4.0SIR1.6A-D471/472-2.3...	1.60	1.69	2.3				2.60	6.00	
6.0	6.0SIR0.7A-D471/472-1.4...	0.70	0.77	1.4	50	1.90	SMC..-6.0	5.50	7.00	
	6.0SIR0.8A-D471/472-1.5...	0.80	0.87	1.5				5.40	7.20	
	6.0SIR0.9A-D471/472-1.6...	0.90	0.97	1.6				5.30	7.30	
	6.0SIR1.1A-D471/472-1.8...	1.10	1.19	1.8				5.10	7.50	
	6.0SIR1.3A-D471/472-2.0...	1.30	1.39	2.0				4.90	7.70	
	6.0SIR1.6A-D471/472-2.3...	1.60	1.69	2.3				4.60	8.00	
	6.0SIR1.85A-D471/472-2.5...	1.85	1.94	2.5				4.40	8.20	
	6.0SIR2.15A-D471/472-2.8...	2.15	2.24	2.8				4.10	8.50	
8.0	8.0SIR1.1A-D471/472-1.8...	1.10	1.19	1.8	70	3.95	SMC..-8.0	8.06	10.44	
	8.0SIR1.3A-D471/472-2.0...	1.30	1.39	2.0				7.66	10.44	
	8.0SIR1.6A-D471/472-2.3...	1.60	1.69	2.3				7.06	10.44	
	8.0SIR1.85A-D471/472-2.5...	1.85	1.94	2.5				6.56	10.44	
	8.0SIR2.15A-D471/472-2.8...	2.15	2.24	2.8				5.96	10.44	
	8.0SIR2.65A-D471/472-3.3...	2.65	2.74	3.3				4.96	10.44	
10.0	10.0SIR1.3A-D471/472-2.0...	1.30	1.39	2.0	80	4.95	SMC..-10.0	9.66	12.44	
	10.0SIR1.6A-D471/472-2.3...	1.60	1.69	2.3				9.06	12.44	
	10.0SIR1.85A-D471/472-2.5...	1.85	1.94	2.5				8.56	12.44	
	10.0SIR2.15A-D471/472-2.8...	2.15	2.24	2.8				7.96	12.44	
	10.0SIR2.65A-D471/472-3.3...	2.65	2.74	3.3				6.96	12.44	
	10.0SIR3.15A-D471/472-3.8...	3.15	3.24	3.8				5.96	12.44	
	10.0SIR4.15A-D471/472-4.8...	4.15	4.24	4.8				3.96	12.44	





MINIPRO

MiniPro Toolholders

PowerBore Toolholders | Micro Toolholders

Vardex Ordering Code System

■ PowerBore Toolholders

C	05	-	D	T	J	-	-	5
1	2		3	4	5			6
1 - Shank Style		2 - Shank Dia.		3 - Bar Dia. [D₁]		4 - Insert Shape		5 - Holder Length [L₂]
C - Carbide S - Steel		04 - 4.0 mm 05 - 5.0 mm 06 - 6.0 mm 08 - 8.0 mm 10 - 10.0 mm 12 - 12.0 mm		A - 4.2 B - 4.6 C - 4.8 D - 5.0 E - 5.2 F - 6.0 G - 6.4 H - 7.9 J - 8.0		C - Diamond 80 Deg.  T - Triangle  W - Trigon 80 Deg. 		A - 57 C - 64 D - 70 E - 76 G - 89 J - 102 P - 152
								6 - Front Relief Angle
								0, 5, 7

■ Micro Toolholders (Sleeves)

S	M	C	16	-	3
1	2	3	4		5
1 - Holder Shape	2 - Holder Type	3 - Cooling	4 - Holder Dia.	5 - Bore Size	
S - Sleeve (Double Ended)	M - Micro (Double Ended)	C - Coolant Channel	10, 12, 16, 20	Micro Size 3, 4, 6, 8, 10	

PowerBore Boring Bars for CD0W Inserts

POWERBORE

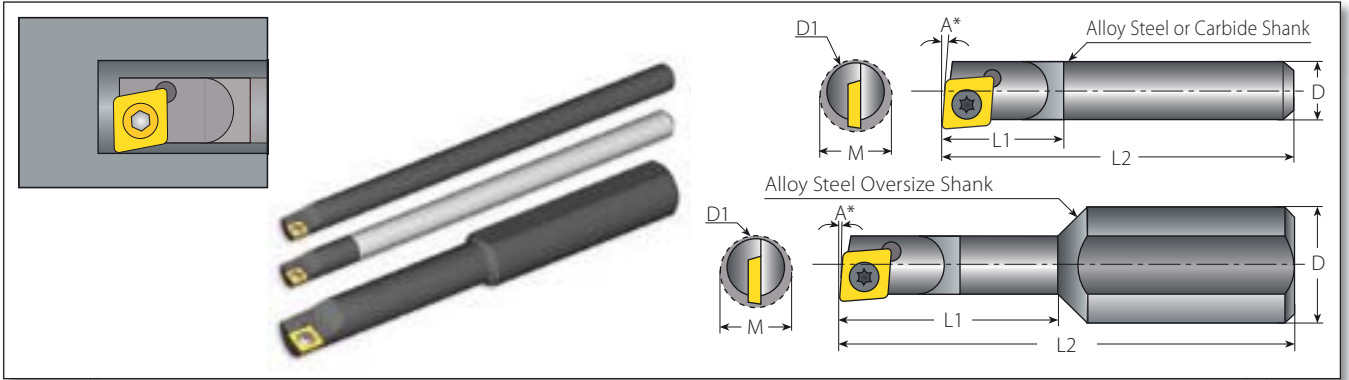

Alloy Steel Shanks - Standard Size

Shank	Ordering Code	Dimensions mm						Spare Parts		
		A	D	D1	M	L2	L1	Insert Type	Screw	Torx Key
		Angle	Shank Dia.	Bar Dia.	Min. Bore	Overall Length	Bar Length			
5.0	S05-ACC--7	7°	5.0	4.2	4.6	64	12	CD0W	VS01	VT51
	S05-BCC--5	5°	5.0	4.6	5.3	64				
	S05-DCC--5	5°	5.0	5.0	6.1	64				
	S05-DCC--0	0°	5.0	5.0	6.4	64				
6.0	S06-FCE--5	5°	6.0	6.0	7.0	76	D1=D	CD0W	VS01	VT51
	S06-FCE--0	0°	6.0	6.0	7.3	76				

Solid Carbide Shank - Standard Size

Shank	Ordering Code	Dimensions mm						Spare Parts		
		A	D	D1	M	L2	L1	Insert Type	Screw	Torx Key
		Angle	Shank Dia.	Bar Dia.	Min. Bore	Overall Length	Bar Length			
4.0	C04-ACP--7	7°	4.0	4.2	4.6	152	12	CD0W	VS01	VT51
5.0	C05-CCJ--5	5°	5.0	4.8	5.5	102				
	C05-DCJ--5	5°	5.0	5.0	6.1	102				
	C05-DCJ--0	0°	5.0	5.0	6.5	102				
6.0	C06-FCJ--5	5°	6.0	6.0	7.0	102	D1=D	CD0W	VS01	VT51
	C06-FCJ--0	0°	6.0	6.0	7.3	102				

Alloy Steel Shanks - Oversize

Shank	Ordering Code	Dimensions mm						Spare Parts		
		A	D	D1	M	L2	L1	Insert Type	Screw	Torx Key
		Angle	Shank Dia.	Bar Dia.	Min. Bore	Overall Length	Bar Length			
8.0	S08-BCA--5	5°	8.0	4.6	5.5	57	25	CD0W	VS01	VT51
	S08-ECA--5	5°	8.0	5.2	5.8	57				
	S08-ECA--0	0°	8.0	5.2	6.2	57				
	S08-GCC--5	5°	8.0	6.4	7.4	64	32			
	S08-GCC--0	0°	8.0	6.4	7.6	64				

* 5° angle for facing and thru-hole boring.
 * 0° angle for thru-hole boring and boring to a shoulder.

PowerBore Boring Bars for TD0W Inserts

POWERBORE

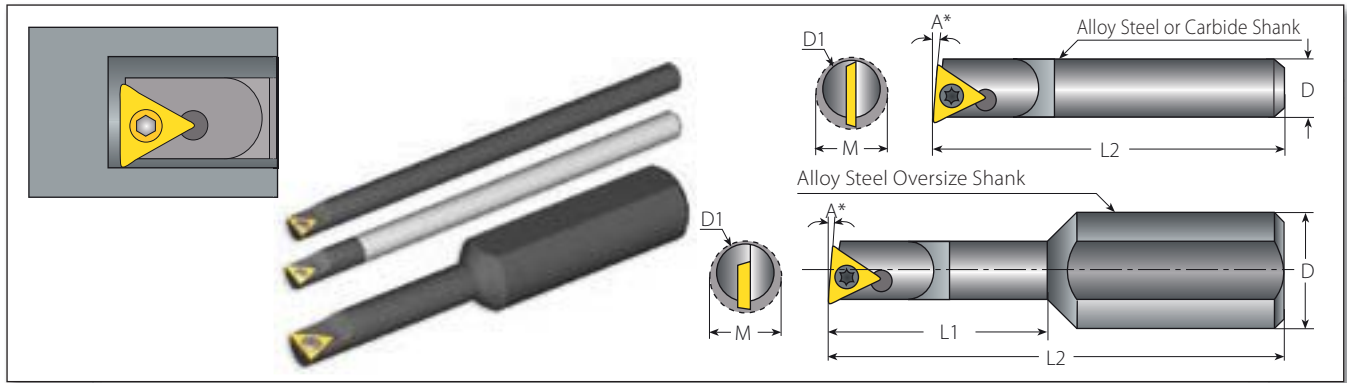

Alloy Steel Shanks - Standard Size

Spare Parts

Shank	Ordering Code	Dimensions mm				Insert Type	Screw	Torx Key
		A	D=D1	M	L2			
		Angle	Bar Dia.	Min. Bore	Overall Length			
5.0	S05-DTG--5	5°	5.0	7.1	89	TD0W	VS01	VT51
	S05-DTG--0	0°	5.0	7.1	89			
6.0	S06-FTJ--5	5°	6.0	7.3	102		VS40	
	S06-FTJ--0	0°	6.0	7.3	102			
8.0	S08-JTJ--5	5°	8.0	9.2	102		VS40	
	S08-JTJ--0	0°	8.0	9.2	102			

Solid Carbide Shank - Standard Size

Spare Parts

Shank	Ordering Code	Dimensions mm				Insert Type	Screw	Torx Key
		A	D=D1	M	L2			
		Angle	Bar Dia.	Min. Bore	Overall Length			
5.0	C05-DTJ--5	5°	5.0	7.1	102	TD0W	VS01	VT51
	C05-DTJ--0	0°	5.0	7.1	102			
6.0	C06-FTJ--5	5°	6.0	7.3	102		VS40	
	C06-FTJ--0	0°	6.0	7.3	102			
8.0	C08-JTJ--5	5°	8.0	9.2	102		VS40	
	C08-JTJ--0	0°	8.0	9.2	102			

Alloy Steel Shanks - Oversize

Spare Parts

Shank	Ordering Code	Dimensions mm						Insert Type	Screw	Torx Key
		A	D	D1	M	L2	L1			
		Angle	Shank Dia.	Bar Dia.	Min. Bore	Overall Length	Bar Length			
12.0	S12-ETC--5	5°	12.0	5.2	6.9	64	25	TD0W	VS01	VT51
	S12-ETC--0	0°	12.0	5.2	6.9	64				
	S12-GTD--5	5°	12.0	6.4	7.6	70	32		VS40	
	S12-GTD--0	0°	12.0	6.4	7.6	70				
	S12-HTE--5	5°	12.0	7.9	9.1	76	38		VS40	
	S12-HTE--0	0°	12.0	7.9	9.1	76				

* 5° angle for facing and thru-hole boring.
 * 0° angle for thru-hole boring and boring to a shoulder.

PowerBore Boring Bars for WC0W Inserts (4213, 4214)

POWERBORE

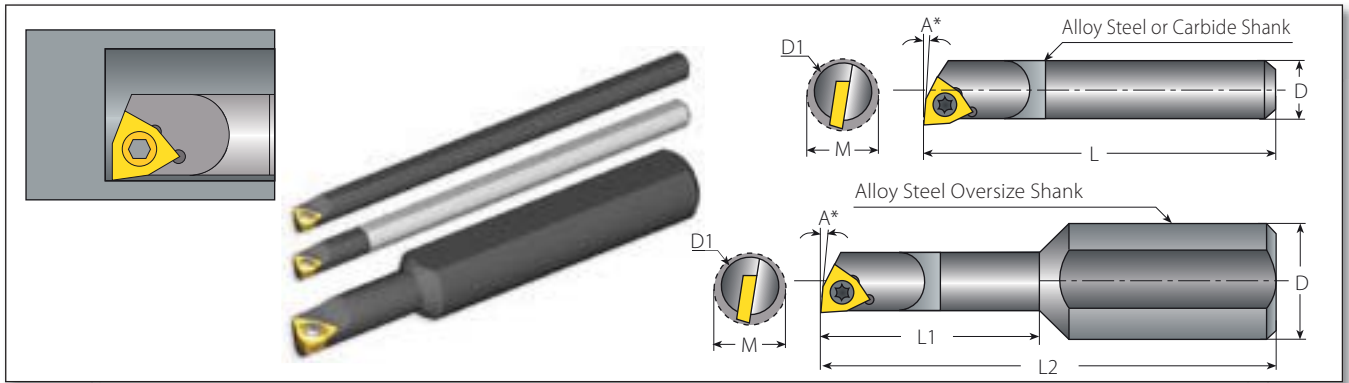

Alloy Steel Shanks - Standard Size

Shank	Ordering Code	Dimensions mm				Spare Parts					
		A	D=D1	M	L	Insert Type	Screw	Torx Key			
		Angle	Bar Dia.	Min. Bore	Bar Length						
5.0	S05-DWC--5	5°	5.0	6.1	64	WC0W4213 WC0W4214	VS40	VT51			
	S05-DWC--0	0°	5.0	6.4							
6.0	S06-FWJ--5	5°	6.0	7.0	102						
	S06-FWJ--0	0°	6.0	7.3							

Solid Carbide Shank - Standard Size

Shank	Ordering Code	Dimensions mm				Spare Parts					
		A	D=D1	M	L	Insert Type	Screw	Torx Key			
		Angle	Bar Dia.	Min. Bore	Bar Length						
5.0	C05-DWJ--5	5°	5.0	6.1	102	WC0W4213 WC0W4214	VS40	VT51			
	C05-DWJ--0	0°	5.0	6.4							
6.0	C06-FWJ--5	5°	6.0	7.0	102						
	C06-FWJ--0	0°	6.0	7.3							

Alloy Steel Shanks - Oversize

Shank	Ordering Code	Dimensions mm						Spare Parts					
		A	D	D1	M	L2	L1	Insert Type	Screw	Torx Key			
		Angle	Shank Dia.	Bar Dia.	Min. Bore	Overall Length	Bar Length						
10.0	S10-EWA--5	5°	10.0	5.2	5.8	57	13	WC0W4213 WC0W4214	VS40	VT51			
	S10-EWA--0	0°	10.0	5.2	6.2	57							
	S10-GWC--5	5°	10.0	6.4	7.4	64	19						
	S10-GWC--0	0°	10.0	6.4	7.6	64							

* 5° angle for facing and thru-hole boring.
* 0° angle for thru-hole boring and boring to a shoulder.

PowerBore Boring Bars for WCOW Inserts (5013, 5014)

POWERBORE

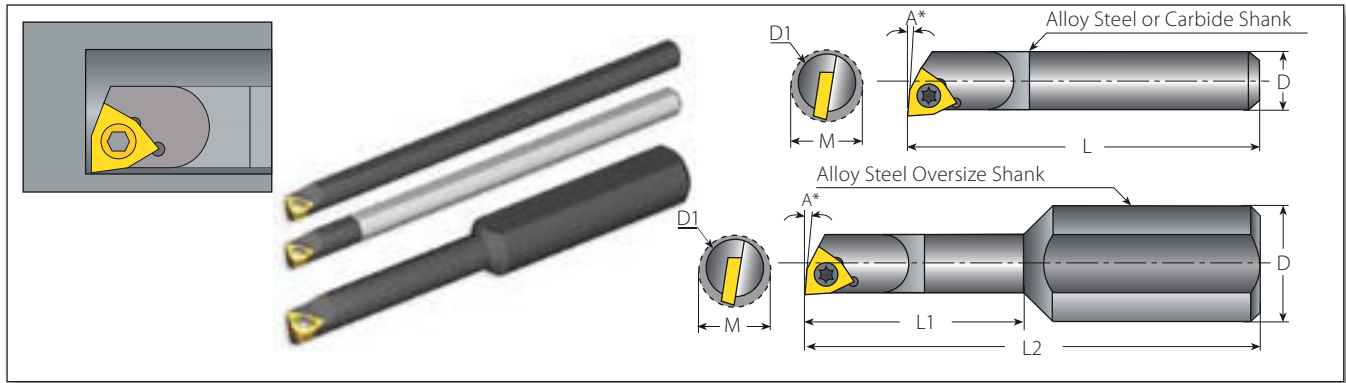

Alloy Steel Shanks - Standard Size

Spare Parts

Shank	Ordering Code	Dimensions mm				Insert Type	Screw	Torx Key
		A	D=D1	M	L			
		Angle	Bar Dia.	Min. Bore	Bar Length			
8.0	S08-JWJ--5	5°	8.0	9.2	102	WCOW5013 WCOW5014	VS41	VT51
	S08-JWJ--0	0°	8.0	9.2				

Solid Carbide Shank - Standard Size

Spare Parts

Shank	Ordering Code	Dimensions mm				Insert Type	Screw	Torx Key
		A	D=D1	M	L			
		Angle	Bar Dia.	Min. Bore	Bar Length			
8.0	C08-JWJ--5	5°	8.0	9.2	102	WCOW5013 WCOW5014	VS41	VT51
	C08-JWJ--0	0°	8.0	9.2				

Alloy Steel Shanks - Oversize

Spare Parts

Shank	Ordering Code	Dimensions mm						Insert Type	Screw	Torx Key
		A	D	D1	M	L2	L1			
		Angle	Shank Dia	Bar Dia.	Min. Bore	Overall Length	Bar Length			
10.0	S10-HWE--5	5°	10.0	7.9	9.2	76	38	WCOW5013 WCOW5014	VS41	VT51
	S10-HWE--0	0°	10.0	7.9	9.2	76				

* 5° angle for facing and thru-hole boring.
* 0° angle for thru-hole boring and boring to a shoulder.

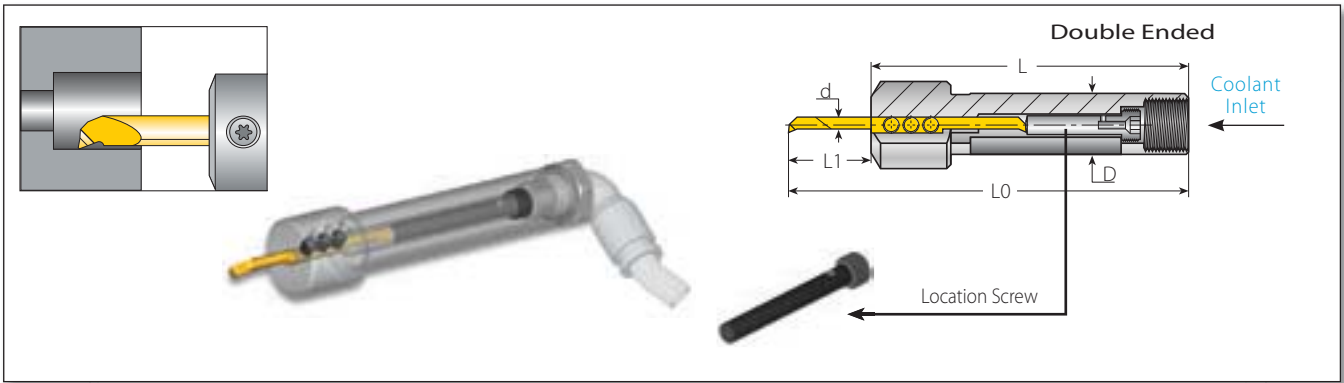

Spare Parts



Micro - Double Ended

Micro Insert Dia.	Shank Dia.	Ordering Code	Dimensions mm			Location Screw*			Clamping Screw x 3							
			d	D	L	L1	L0	Screw	M	Key	Screw	Key				
3	10	SMC10-3.0	80	9 - Short	89	AGISM8X28	28	K4.0	M4X0.7X4.0	K2.0						
	12	SMC12-3.0		16 - Medium	96						AGISM8X21	21				
	16	SMC16-3.0	95	9 - Short	104	AGISM8X49	49									
	20	SMC20-3.0		16 - Medium	111	AGISM8X42	42									
4	10	SMC10-4.0	80	9 - Short	89	AGISM8X28	28				K4.0	M4X0.7X4.0	K2.0			
	12	SMC12-4.0		16 - Medium	96	AGISM8X21	21									
	16	SMC16-4.0	95	9 - Short	104	AGISM8X49	49									
	20	SMC20-4.0		16 - Medium	111	AGISM8X42	42									
6	12	SMC12-6.0	80	9 - Short	89	AGISM8X28	28							K4.0	M4X0.7X4.0	K2.0
	16	SMC16-6.0		16 - Medium	96	AGISM8X21	21									
	20	SMC20-6.0	95	9 - Short	104	AGISM8X49	49									
	20	SMC20-6.0		16 - Medium	111	AGISM8X42	42									
8	16	SMC16-8.0	95	12 - Short	107	AGISM8X33	33	K4.0	M6X1.0X5.0	K3.0						
	20	SMC20-8.0		20 - Medium	115	AGISM8X25	25									
	20	SMC20-8.0	95	28 - Long	123	AGISM8X17	17									
	16	SMC16-10.0		15 - Short	110	AGISM8X30	30									
10	20	SMC20-10.0	95		25 - Medium	120	AGISM8X20				20					
	20	SMC20-10.0		35 - Long	130	AGISM8X10	10									

* Every toolholder package contains the full range of location screws needed.



For Grooving and Turning Solutions
visit
GROOVEX
Innovative Grooving & Turning Solutions
www.vargus.com

MINIPRO

MiniPro Technical Data

Recommended Grades, Cutting Speeds Vc [m/min], Feed f [mm/rev] and Max Depth [mm]



Material Group	Vargus No.	Material	Hardness Brinell HB	Vc [m/min]		Feed [mm/rev]			Max Depth [mm]			
				Coated		Power Bore	Micro Boring	Micro Grooving	PowerBore		Micro Boring	
				VTX (PowerBore)	VMX Micro				TDOW CDOW	WDOW		
P Steel	1	Unalloyed Steel	Low Carbon (C=0.1-0.25%)	125	115-190	50-120	0.25	0.05	0.03	0.45	0.6	0.4
	2		Medium Carbon (C=0.25-0.55%)	150	100-175	40-100	0.2	0.04	0.02	0.45	0.6	0.4
	3		High Carbon (C=0.55-0.85%)	170	90-165	30-80	0.15	0.03	0.01	0.45	0.6	0.4
	4	Low Alloy Steel (alloying elements ≤ 5%)	Non Hardened	180	85-145	50-70	0.2	0.04	0.02	0.35	0.5	0.3
	5		Hardened	275	75-140	40-60	0.15	0.04	0.01	0.35	0.5	0.3
	6		Hardened	350	70-135	30-50	0.1	0.03	0.01	0.35	0.5	0.3
	7	High Alloy Steel (alloying elements > 5%)	Annealed	200	70-110	30-50	0.1	0.04	0.02	0.18	0.4	0.15
	8		Hardened	325	50-100	25-40	0.05	0.03	0.01	0.18	0.4	0.15
	9	Cast Steel	Low Alloy (alloying elements < 5%)	200	75-140	30-50	0.25	0.04	0.02	0.18	0.4	0.15
	10		High Alloy (alloying elements > 5%)	225	60-120	25-40	0.1	0.04	0.02	0.18	0.4	0.15
M Stainless Steel	11	Stainless Steel Ferritic	Non Hardened	200	70-130	60-100	0.2	0.04	0.01	0.22	0.5	0.2
	12		Hardened	330	60-115	40-60	0.08	0.03	0.01	0.18	0.4	0.15
	13	Stainless Steel Austenitic	Austenitic	180	90-140	50-90	0.2	0.04	0.01	0.22	0.5	0.2
	14		Super Austenitic	200	40-110	40-60	0.08	0.04	0.01	0.18	0.4	0.15
	15	Stainless Steel Cast Ferritic	Non Hardened	200	90-120	40-60	0.2	0.04	0.02	0.22	0.5	0.2
	16		Hardened	330	65-110	30-50	0.08	0.03	0.01	0.18	0.4	0.15
	17	Stainless Steel Cast Austenitic	Austenitic	200	85-110	40-60	0.2	0.04	0.02	0.22	0.5	0.2
	18		Hardened	330	60-100	30-50	0.08	0.03	0.01	0.18	0.4	0.15
K Cast Iron	28	Malleable Cast Iron	Ferritic (short chips)	130	70-160	50-70	0.15	0.02	0.02	0.3	0.4	0.25
	29		Pearlitic (long chips)	230	60-145	50-70	0.10	0.01	0.01	0.3	0.4	0.25
	30	Grey Cast Iron	Low Tensile Strength	180	70-130	50-70	0.15	0.02	0.02	0.45	0.6	0.4
	31		High Tensile Strength	260	60-115	40-60	0.1	0.01	0.02	0.45	0.6	0.4
	32	Nodular Sg Iron	Ferritic	160	125-160	50-70	0.15	0.02	0.02	0.45	0.6	0.4
	33		Pearlitic	260	90-120	60-80	0.1	0.01	0.01	0.45	0.6	0.4
N Non-Ferrous Metals	34	Aluminium Alloys Wrought	Non Aging	60	100-365	100-300	0.3	0.03	0.03	0.63	1.0	0.5
	35		Aged	100	80-220	100-150	0.2	0.03	0.03	0.63	1.0	0.5
	36	Aluminium Alloys	Cast	75	200-400	100-150	0.3	0.03	0.03	0.63	1.0	0.5
	37		Cast & Aged	90	200-280	60-100	0.2	0.03	0.03	0.63	1.0	0.5
	38	Aluminium Alloys	Cast Si 13-22%	130	60-180	100-150	0.3	0.02	0.02	0.63	1.0	0.5
	39	Copper and Copper Alloys	Brass	90	80-225	60-100	0.3	0.03	0.03	0.63	1.0	0.5
40	Bronze And Non Leaded Copper		100	80-255	60-100	0.2	0.03	0.03	0.63	1.0	0.5	
S Heat Resistant Material	19	High Temperature Alloys	Annealed (iron based)	200	45-60	25-45	0.2	0.04	0.01	0.22	0.5	0.2
	20		Aged (iron based)	280	30-50	20-30	0.08	0.03	0.01	0.18	0.4	0.15
	21		Annealed (nickel or cobalt based)	250	20-30	15-20	0.08	0.01	0.01	0.18	0.4	0.15
	22		Aged (nickel or cobalt based)	350	15-25	10-15	0.05	0.01	0.01	0.18	0.4	0.15
	23	Titanium Alloys	Pure 99.5 Ti	400Rm	140-170	60-100	0.05	0.02	0.02	0.18	0.4	0.15
24	α+β Alloys		1050Rm	50-70	40-50	0.05	0.02	0.02	0.18	0.4	0.15	
H Hardened Material	25	Extra Hard Steel	Hardened & Tempered	45-50HRc	45-65	20-45	0.02	0.01	0.01	0.05	0.2	0.05
	26			51-55HRc	45-60	20-40	0.01	0.01	0.01	0.05	0.1	0.05





Grades

VTX

General use carbide grade. TiAlN coated.

VMX

General use carbide grade for Micro inserts. TiN coated

Spare Parts for PowerBore line						
Insert	Boring Bar	Insert	Torx Screw	Screw Description	Torx Key	Torx Size
	A	CD0W	VS01	1-72 Oval X 2.77LG.	VT51	T6
	B	TD0W Min. Bore 7.1 > Bore 7.1	VS01 VS40	1-72 Oval X 2.77LG. M2 X 0.4 X 3.86LG.		
	E	WC0W4213, WC0W4214	VS40	M2 X 0.4 X 3.86LG.		
	F	WC0W5013, WC0W5014	VS41	M2 X 0.4 X 4.90LG.		





SHAVIV
Leading Deburring Solutions

The Finishing Touch



SHAVIV hand deburring tools offer a range of cost-effective and efficient solutions to companies across all industry sectors that need to remove burrs from different materials. The tools are renowned for providing “the finishing touch” in a host of applications, such as hole edges, straight edges, flat surfaces, keyways and corners.

- 
Die & Mold
- 
Electrical
- 
Plastic
- 
Automotive
- 
Metal
- 
Plumbing
- 
Aviation
- 
DIY

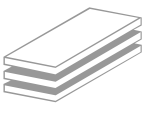
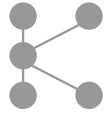
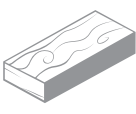
- 
Metal
- 
Aluminum
- 
Copper
- 
Cast Iron
- 
Plastic
- 
Wood



GROOVEX
Innovative Grooving & Turning Solutions

The increasingly popular and rapidly growing **GROOVEX** line, established in 2011, provides a comprehensive line of products for grooving, boring, turning and micro-machining solutions across all industry sectors.



VG-Cut



microscope



Mini-V



GrooVical

With a network of 13 international companies and hundreds of distributors, warehouses and certified ISO 9001 manufacturing facilities, VARGUS Ltd. serves customers in more than 100 countries around the globe. A customer-focused organization, VARGUS Ltd. is committed to providing innovative products and solutions of the highest quality and excellent value, and is renowned for its technical expertise and uncompromising service.

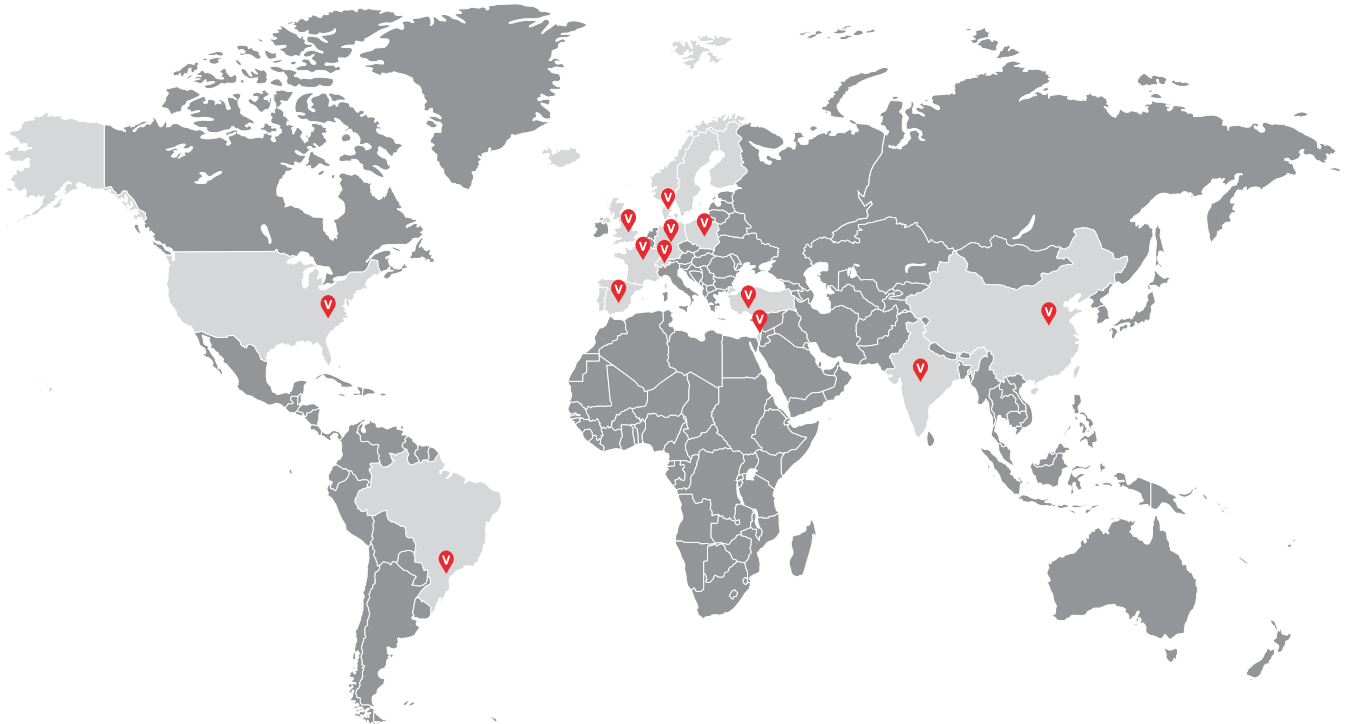

VARGUS Ltd. - Global Headquarters +972 4 9855 101 | mrktg@vargus.com

EUROPE

 **DENMARK**
VARGUS Scandinavia
+45 8794 4100
vargus@vargus.dk

 **FRANCE**
VARGUS France
+33 1 4601 7060
commercial@vargus.fr

 **GERMANY**
VARGUS Germany
+49 7043 36 161
info@vargus.de

 **ISRAEL**
NEUMO-VARGUS
+972 3 537 3275
neumo@neumo-vargus.co.il

 **POLAND**
VARGUS Poland
+48 46 834 9904 / 46 831 5140
vargus@neumo.pl

 **SPAIN**
VARGUS Ibérica
+34 977 52 49 00
sales@vargus.es

 **SWITZERLAND**
VARGUS Switzerland
+41 41784 2121
info@vargus.ch

 **TURKEY**
VARGUS Turkey
+90 212 875 01 41
info@vargusturkey.com

 **UNITED KINGDOM**
VARGUS UK
+44 1952 583 222
tooling.uk@vargustooling.co.uk

ASIA

 **CHINA**
VARGUS China
+86 21 516 88300
info@varguschina.net

 **INDIA**
VARGUS India
+91 2135 654748
info@vargusindia.com

NORTH & LATIN AMERICA

 **BRAZIL**
VARGUS Brazil
+55 47 3084 8001
info@vargus.com.br

 **USA**
VARGUS USA
+1 800 828 8765 / 608 756 4930
sales@vargususa.com

VARGUS | Tool Selector and
GENiUS™ | CNC Program Generator



The most popular and advanced thread turning and thread milling software on the market today.

Now available in 3 versions
at www.vargus.com

VARGUS
GENiUS™
ONLINE

VARGUS
GENiUS™
DESKTOP

VARGUS
GENiUS™
setup.exe